

Intelligent Drivesystems, Worldwide Services



GB

Migration Guide

Decentralised drive technology

from SK 300E to SK 200E

11.10.2012



NORD
DRIVESYSTEMS

Contents

Contents	2
1. Introduction	3
1.1 Overview of components	3
1.2 Overview of frequency inverters	4
2. Recoding	5
2.1 Frequency inverter	5
2.1.1 performance levels	5
2.1.2 Performance levels	5
2.2 Options and components	10
2.3 AS Interface	12
2.4 External braking resistor	13
2.5 ATEX	14
2.6 Wall-mounting kit	14
3. Power and and control terminal connection	15
3.1 Power connection	15
3.2 Control terminal connection	16
3.2.1 Details of control terminals for connection units and customer interfaces	19
3.2.2 Details of control terminals for the technology options	24
4. Dimensions	28
4.1 Frequency inverter - motor mounted	28
4.1.1 Frequency inverter SK 300E	28
4.1.2 Frequency inverter SK 2xxE	29
4.2 Frequency inverter - wall-mounting	30
4.2.1 Frequency inverter SK 300E with WMK-DA1	30
4.2.2 Frequency inverter SK 2xxE with SK TIE4-WMK-1	31
4.3 Options	31
4.3.1 Frequency inverter technology unit (SK 2xxE)	31
4.3.2 Braking resistors (external braking resistors)	32
5. Additional information and documents	33
List of illustrations	34
List of tables	35

















1. Introduction

This document serves for the recoding of drive solutions with SK 300E series frequency inverters to the new model SK 200E. As well as the comparison and recoding of the usual modules in the first part of the document, the middle part deals with the comparison of the connection terminals and the final part describes the dimensions of the devices.

Both series (SK 300E and SK 200E) are similar in their basic structure, however the performance and scope of functions of the new series has been considerably increased. The following document only describes the functions and solutions which could also be implemented with the SK 300E. In addition, in the description of possible options, only the most common have been listed in detail.

1.1 Overview of components

The following table lists and compares the individual components for the conversion of the two different frequency inverter series. A distinction is made between the standard IP 55 version and the "coated" IP 66 version. The details for the IP 66 versions are shown in brackets.

SK 300E		Components	SK 200E	
Designation	Illustration		Illustration	Designation
SK 300E-xxx-xxx-B-(C)		Frequency inverter		SK 200E-xxx-xxx-A-(C)
SK TI 0/x-xxx-(C)		Connection unit		SK TI4-x-2xx-x-(C)
SK TU2-POT-(C)		PotentiometerBox		SK CU4-POT
SK CU2-xxx-(C)		Customer interface		SK CU4-xxx
SK TU2-xxx-(C)		Technology option		SK TU4-xxx-(C)
SK PAR-2H		Parameterbox		SK PAR-3H
SK WMK-DA1		Wall-mounting		SK TIE4-WMK-1
SK BR3-xxx/xxx		Braking resistor		SK BRE4-x-x00-x00





SK 300E		Components	SK 200E	
Designation	Illustration		Illustration	Designation
M12 System connector		System connectors		SK TU4-xxx-M12
MA H10E		Motor plug connector		SK TIE4-HAN10E

Table 1: Overview of components

1.2 Overview of frequency inverters

The assignment of the inverter versions according to the supply voltage and the rated power of the devices is summarised below. A distinction is made between the frequency inverter and the connection unit. The details for the IP 66 versions are shown in brackets.

SK 300E	Mains type Power level	SK 2xxE
Designation		Designation
SK 300E-xxx-323-B-(C)	1 phase~ 230V / 240V 370W ... 550W / ½ ... ¾ hp	SK 200E-xxx-123-A-(C)
SK 300E-xxx-323-B-(C)	1 phase~ 230V / 240V 750W ... 1.1kW / 1 ... 1 ½ hp	SK 205E-xxx-123-A-(C) ¹ Attention: different frequency inverter version!
SK 300E-xxx-323-B-(C)	3 phase~ 230V / 240V 370W ... 550W / ½ ... ¾ hp	SK 200E-xxx-323-A-(C)
SK 300E-xxx-340-B-(C)	3 phase~ 400V / 480V 550W ... 4.0 kW / ¾... 5 hp	SK 200E-xxx-340-A-(C)

Table 2: Overview of frequency inverters - Power levels

SK 300E	Information	SK 2xxE
Designation Note		Designation Note
SK TI0/1-230-(C) ^a SK TI0/1-400-(C) ^b	For motor mounting and wall mounting. Provides space for installation of the Customer Unit.	SK TI4-x-2xx-x-(C) The connection units are directly assigned to the frequency inverter versions, mains tapes and power levels.
SK TI0/2-230-(C) ^a SK TI0/2-400-(C) ^b	In addition: Mounting of system plug connectors (motor / mains connection).	

^a for all 230V inverters; ^b for all 400V inverters

Table 3: Overview of connection units

¹ higher powers are available (refer to note / Section 2.1.2)

2. Recoding

SK 2xxE series frequency inverters are available in a total of 8 different performance levels (SK 200E, SK 205E, SK 210E, SK 215E, SK 220E, SK225E, SK 230E, SK 235E). In general, a distinction is made between SK 2x0E and SK 2x5E devices. These essentially differ in the available I/Os and the control voltage supply (SK 2x0E - integrated 24V mains unit, or SK 2x5E - without 24V mains unit) or in the features "AS interface" (SK 22xE and SK 23xE) and "Functional safety" (SK 21xE and SK 23xE). A distinction is made between the standard IP 55 version and the "coated" IP 66 version. The details for the IP 66 versions are shown in brackets.

2.1 Frequency inverter

2.1.1 performance levels

SK 300E Designation	Features	SK 2xxE Designation
SK 300E-xxx-xxx-B-(C)	Standard	SK 20xE-xxx-xxx-A-(C)
not available	Standard + Functional Safety ²	SK 200E-xxx-xxx-A-(C)
SK 300E-xxx-xxx-B-(C) + SK TU2-ASx-(C) ³	Standard + AS interface	SK 22xE-xxx-xxx-A-(C) ³
not available	Standard + Functional Safety ² + AS interface	SK 23xE-xxx-xxx-A-(C)

Table 4: Overview of SKL 2xxE performance levels

2.1.2 Performance levels

The operation of SK 300E brake motors with the SK 2x0E requires an **additional** Customer Interface **SK CU4 MBR / part number 275271010**. SK 2x5E frequency inverters are equipped with an integrated half-wave rectifier to control the electro-mechanical brake.

The following recoding does not consider applications with AS interface functionalities. For these applications, the corresponding SK 22xE types with their associated connection unit according to Section 2.3 should be noted.

A distinction is made between the standard IP 55 version and the "coated" IP 66 version. The details for the IP 66 versions are shown in brackets.

² corresponds to "Safe pulse block"

³ depending on the AS interface application (A/B slaves or only A slaves)

Power level: 1 phase 230V/240V ~

SK 300E	Type / Components	SK 2xxE
Designation Part Number		Designation Part Number
SK 300E-370-323-B-(C) 275120370 (275160370)	Frequency inverter 370 W / ½ hp	SK 200E-370-123-A-(C) 275226104 (275226604)
SK TI 0/1 230-(C) SK TI 0/2 230-(C)	Connection unit	SK TI4-1-200-1-(C) 275270040 (275270540)
-	Internal brake resistor	SK BRI 4-1-100-100 275272005
SK 300E-550-323-B-(C) 275120550 (275160550)	Frequency inverter 550 W / ¾ hp	SK 200E-550-123-A-(C) 275226105 (275226605)
SK TI 0/1 230-(C) SK TI 0/2 230-(C)	Connection unit	SK TI4-1-200-1-(C) 275270040 (275270540)
-	Internal brake resistor	SK BRI 4-1-100-100 275272005
SK 300E-750-323-B-(C) 275120750 (275160750)	Frequency inverter 750 W / 1 hp	SK 205E -750-123-A-(C) 275222106 (275222606)
SK TI 0/1 230-(C) SK TI 0/2 230-(C)	Connection unit	SK TI4-2- 205 -1-(C) 275270001 (275270501)
-	Internal brake resistor	SK BRI 4-1-100-100 275272005
SK 300E-111-323-B-(C) 275121100 (275161100)	Frequency inverter 1.1 kW / 1 ½ hp	SK 205E -111-123-A-(C) 275222107 (275222607)
SK TI 0/1 230-(C) SK TI 0/2 230-(C)	Connection unit	SK TI4-2- 205 -1-(C) 275270001 (275270501)
-	Internal brake resistor	SK BRI 4-1-100-100 275272005

Table 5: 1 phase 230V/240V ~
Power level: 3 phase 230V/240V ~

SK 300E	Type / Components	SK 2xxE
Designation Part Number		Designation Part Number
SK 300E-370-323-B-(C) 275120370 (275160370)	Frequency inverter 370 W / ½ hp	SK 200E-370-323-A-(C) 275226204 (275226704)
SK TI 0/1 230-(C) SK TI 0/2 230-(C)	Connection unit	SK TI4-1-200-3-(C) 275270140 (275270640)
-	Internal brake resistor	SK BRI 4-1-200-100 275272008

SK 300E	Type / Components	SK 2xxE
Designation Part Number		Designation Part Number
SK 300E-550-323-B-(C) 275120550 (275160550)	Frequency inverter 550 W / ¾ hp	SK 200E-550-323-A-(C) 275226205 (275226705)
SK TI 0/1 230-(C) SK TI 0/2 230-(C)	Connection unit	SK TI4-1-200-3-(C) 275270140 (275270640)
-	Internal brake resistor	SK BRI 4-1-200-100 275272008
SK 300E-750-323-B-(C) 275120750 (275160750)	Frequency inverter 750 W / 1 hp	SK 200E-750-323-A-(C) 275226206 (275226706)
SK TI 0/1 230-(C) SK TI 0/2 230-(C)	Connection unit	SK TI4-1-200-3-(C) 275270140 (275270640)
-	Internal brake resistor	SK BRI 4-1-200-100 275272008
SK 300E-111-323-B-(C) 275121100 (275161100)	Frequency inverter 1.1 kW / 1 ½ hp	SK 200E-111-323-A-(C) 275226207 (275226707)
SK TI 0/1 230-(C) SK TI 0/2 230-(C)	Connection unit	SK TI4-1-200-3-(C) 275270140 (275270640)
-	Internal brake resistor	SK BRI 4-1-200-100 275272008
SK 300E-151-323-B-(C) 275121500 (275161500)	Frequency inverter 1.5 kW / 2 hp	SK 200E-151-323-A-(C) 275226208 (275226708)
SK TI 0/1 230-(C) SK TI 0/2 230-(C)	Connection unit	SK TI4-2-200-3-(C) 275270141 (275270641)
-	Internal brake resistor	SK BRI 4-1-200-100 275272008
SK 300E-221-323-B-(C) 275122200 (275162200)	Frequency inverter 2.2 kW / 3 hp	SK 200E-221-323-A-(C) 275226209 (275226709)
SK TI 0/1 230-(C) SK TI 0/2 230-(C)	Connection unit	SK TI4-2-200-3-(C) 275270141 (275270641)
-	Internal brake resistor	SK BRI 4-1-200-100 275272008

Table 6: 3 phase 230V/240V ~

Power level: 3 phase 400V/480V ~

SK 300E	Type / Components	SK 2xxE
Designation Part Number		Designation Part Number
SK 300E-550-340-B-(C) 275120555 (275160555)	Frequency inverter 550 W / ¾ hp	SK 200E-550-340-A-(C) 275226305 (275226805)
SK TI 0/1,400-(C) SK TI 0/2,400-(C)	Connection unit	SK TI4-1-200-3-(C) 275270140 (275270640)
-	Internal brake resistor	SK BRI 4-1-400-100 275272012
SK 300E-750-340-B-(C) 275120755 (275160755)	Frequency inverter 750 W / 1 hp	SK 200E-750-340-A-(C) 275226306 (275226806)
SK TI 0/1,400-(C) SK TI 0/2 400-(C)	Connection unit	SK TI4-1-200-3-(C) 275270140 (275270640)
-	Internal brake resistor	SK BRI 4-1-400-100 275272012
SK 300E-111-340-B-(C) 275121105 (275161105)	Frequency inverter 1.1 kW / 1 ½ hp	SK 200E-111-340-A-(C) 275226307 (275226807)
SK TI 0/1 400-(C) SK TI 0/2 400-(C)	Connection unit	SK TI4-1-200-3-(C) 275270140 (275270640)
-	Internal brake resistor	SK BRI 4-1-400-100 275272012
SK 300E-151-340-B-(C) 275121505 (275161505)	Frequency inverter 1.5 kW / 2 hp	SK 200E-151-340-A-(C) 275226308 (275226808)
SK TI 0/1 400-(C) SK TI 0/2 400-(C)	Connection unit	SK TI4-1-200-3-(C) 275270140 (275270640)
-	Internal brake resistor	SK BRI 4-1-400-100 275272012
SK 300E-221-340-B-(C) 275122205 (275162205)	Frequency inverter 2.2 kW / 3 hp	SK 200E-221-340-A-(C) 275226309 (275226809)
SK TI 0/1,400-(C) SK TI 0/2 400-(C)	Connection unit	SK TI4-1-200-3-(C) 275270140 (275270640)
-	Internal brake resistor	SK BRI 4-1-400-100 275272012

SK 300E	Type / Components	SK 2xxE
Designation Part Number		Designation Part Number
SK 300E-301-340-B-(C) 275123005 (275163005)	Frequency inverter 3.0 kW / 4 hp	SK 200E-301-340-A-(C) 275226310 (275226810)
SK TI 0/1,400-(C) SK TI 0/2 400-(C)	Connection unit	SK TI4-2-200-3-(C) 275270141 (275270641)
-	Internal brake resistor	SK BRI 4-1-400-100 275272012
SK 300E-401-340-B-(C) 275124005 (275164005)	Frequency inverter 4.0 kW / 5 hp	SK 200E-401-340-A-(C) 275226311 (275226811)
SK TI 0/1,400-(C) SK TI 0/2 400-(C)	Connection unit	SK TI4-2-200-3-(C) 275270141 (275270641)
-	Internal brake resistor	SK BRI 4-1-400-100 275272012

Table 7: 3 phase 400V/480V ~

2.2 Options and components

A distinction is made between the standard IP 55 version and the "coated" IP 66 version. The details for the IP 66 versions are shown in brackets.

SK 300E option	Information	SK 2xxE option	Information
Designation Part Number		Designation Part Number	
SK CU2-BSC-(C) 275130010 (275170010)	Customer Unit Basic I/O 3 digital inputs 1 analog input 0...10V (differential input)	SK 200E-...-A-(C) incl.	The analog input of the SK 200E is not a differential input.
	If the analog input is used as a differential input.	SK TU4-IOE-(C) 275281106 (275281156) SK TI4-TU-BUS-(C) 275280000 (275280500)	Use this additional technology option and connection unit if a differential input is required.
SK CU2-STD-(C) 275130020 (275170020)	Customer interf. Standard I/O 4 digital inputs 2 analog inputs 0...10V, 0/4...20mA (differential input) 1 analog / digital output	SK 200E-...-A-(C) incl.	The frequency inverter does not have an analog output. Only 2 digital outputs are available
	If the analog output is used.	SK TU4-IOE-(C) 275281106 (275281156) SK TI4-TU-BUS-(C) 275280000 (275280500)	The analog output must be implemented with one of these additional technology options and connection units.
SK TU2-POT-(C) 275130060 (275170060)	Potentiometerbox 1 Potentiometer 0...100 % 1 switch left-0-right	SK CU4-POT 275271207	Potentiometerbox 1 potentiometer 0...100 % 1 switch left-0-right IP 66 = Standard
SK ATX-POT 275142000	ATEX potentiometer 1 potentiometer 0...100 % 10kΩ	SK ATX-POT 275142000	ATEX potentiometer 1 potentiometer 0...100 % 10kΩ IP 66 = Standard
SK TU2-CTR-(C) 275130130 (275170130)	Control box 4-digit, 7-segment LED display Keyboard	not available	not available
SK PAR-2H 278910100	Hand-held Parameterbox Plain text display Keyboard incl. Connection cable and M12 plug connector	SK PAR-3H 275281014	Hand-held Parameterbox Plain text display Keyboard incl. RJ12-RJ12 connection cable

Table 8: Overview of options 1

More recent software files are required for the field bus technology option SK TU4-xxx-(C).

SK 300E option	Information	SK 2xxE option	Information
Designation Part Number		Designation Part Number	
SK TU2-PBR-(C) 275130070 (275170070)	PROFIBUS DP module Baud rate: 1.5 MBit/s 2 x 5-pin M12 system plug connector	SK TU4-PBR-(C) 275281100 (275281150)	PROFIBUS DP module Baud rate: 12 MBit/s
SK TU2-PBR-24V-(C) 275130110 (275170110)	external 24V power supply Baud rate: 12 MBit/s 2 x 5-pin M12 system plug connector	SK TI4-TU-BUS-(C) 275280000 (275280500)	Use with connection unit for Technology box.
SK TU2-PBR-KL-(C) 275130065 (275170065)	8 pin terminal Baud rate: 1.5 MBit/s	SK TIE4-M12-PBR 275274500	Use optional 2 x 5-pin M12 system plug connector
SK TU2-IBS-(C) 275130080 (275170080)	INTERBUS module Baud rate: 500 kBit/s 2 x 5-pin M12 system plug connector	not available	not available
SK TU2-DEV-(C) 275130090 (275170090)	DEVICENET module Baud rate: 500 kBit/s 1 x 5-pin M12 system plug connector	SK TU4-DEV-(C) 275281102 (275281152)	DEVICENET module Baud rate: 500 kBit/s
		SK TI4-TU-BUS-(C) 275280000 (275280500)	Use with connection unit for Technology box.
		SK TIE4-M12-CAO 275274501	Use optional 1 x 5-pin M12 system plug connector
SK TU2-CAO-(C) 275130100 (275170100)	CANopen module Baud rate: 1 MBit/s 2 x 5-pin M12 system plug connector	SK TU4-CAO-(C) 275281101 (275281151)	CANopen module Baud rate: 1 MBit/s
		SK TI4-TU-BUS-(C) 275280000 (275280500)	Use with connection unit for Technology box.
		SK TIE4-M12-CAO 275274501	Use optional 1 x 5-pin M12 system plug connector

Table 9: Overview of options 2

2.3 AS Interface

- ∅ If the technology option SK TU2-ASx of the SK 300E is only used as an I/O extension, the SK 20xE must be used with an additional technology option SK TU4-IOE-(C) and the appropriate connection unit SK TI4-TU-BUS-(C).
- ∅ SK 300E with SK TU2-AS1-(C): The "extended string transfer" (refer to BU 0090) cannot be implemented with the SK 22xE.
- ∅ SK 300E with SK TU2-AS3: The SK 220E must be used in order to utilise the A/B slave functionality.
- ∅ SK 225E: The power consumption of the frequency inverter is 290 mA. The AS interface mains unit (PELVI) must be dimensioned accordingly. In addition, the supply for further sensors or actuators must be taken into account.
- ∅ SK 22xE: The optional M12 system plug connector SK TIE4-M12-ASI must always be planned for the connection of the AS interface cable.
- ∅ For the connection of digital inputs and digital outputs via the flanged sockets of the SK TU2-ASx the additional M12 system plug connector SK TIE4-M12-INI is available for connection to the SK 2xxE.

SK 300E option	Information	SK 2xxE option	Information
Designation Part Number		Designation Part Number	
SK TU2-AS1-(C) 275130120 (275170120)	AS interface module 2 x 5-pin M12 system plug connector for ASI and AUX 2 x 5-pin M12 system plug connector socket for additional digital inputs and digital outputs Slave profile S 7.4.0	SK 225E-...-(C) incl. plus SK TI4-x-225-x-(C) SK TIE4-M12-ASI 275274502 SK TIE4-M12-INI 275274503	AS interface module is integrated. Slave profile S 7.0 Use the optional 1 x 5-pin M12 system plug connector to connect the AS interface cable and the 1 x 4-pin M12 system plug connect the sensors or actuators.
SK TU2-AS3-(C) 275130125 (275170125)	AS interface module 2 x 5-pin M12 system plug connector for ASI and AUX 2 x 5-pin M12 system plug connector socket for additional digital inputs and digital outputs Slave profile S 7.A	SK 200E-...-(C) ⁴ incl. plus SK TI4-x-220-x-(C) SK TIE4-M12-ASI 275274502 SK TIE4-M12-INI 275274503	AS interface module is integrated. Slave profile S 7.A Use the optional 1 x 5-pin M12 system plug connector to connect the AS interface cable and the 1 x 4-pin M12 system plug connect the sensors or actuators.

Table 10: Overview of AS interface options

⁴ Only SK 225E FIs are available for single phase 230V applications with powers of 0.75kW and 1.1kW.

2.4 External braking resistor

If the SK 300E application does not have an external braking resistor, an internal braking resistor SK BRI4-x-xxx-xxx must be used with the SK 2xxE

If the SK 300E application has an external braking resistor SK BR3-xxx/xxx-TI x/x, the SK 2xxE must be equipped with an external braking resistor SK BRE 4-x-xxx-xxx according to the following table. In this case, the internal braking resistor may not be used with the SK 2xxE.

The external braking resistors for the SK 2xxE generally have protection class IP 67.

SK 300E Braking resistor	Information	SK 2xxE Braking resistor	Information
Designation Part Number		Designation Part Number	
SK BR3-82/200-TI 0/1 275140020	External braking resistor for SK 300E-370-323-B-(C) ... SK 300E-221-323-B-(C)	SK BRE 4-1-200-100 275273008	External braking resistor for SK 2xxE-370-323-A-(C) ... SK 2xxE-221-323-A-(C)
SK BR3-82/200-TI 0/2 275140040			
SK BR3-120/100-TI 0/1 275140010	External braking resistor for SK 300E-550-340-B-(C) ... SK 300E-151-340-B-(C)	SK BRE 4-1-400-100 275273012	External braking resistor for SK 2xxE-550-340-A-(C) ... SK 2xxE-221-340-A-(C)
SK BR3-120/100-TI 0/2 275140030			
SK BR3-82/200-TI 0/1 275140020	External braking resistor for SK 300E-221-340-B-(C) ... SK 300E-401-340-B-(C)	SK BRE 4-2-200-200 275273108	External braking resistor for SK 2xxE-301-340-A-(C) ... SK 2xxE-401-340-A-(C)
SK BR3-82/200-TI 0/2 275140040			

Table 11: Overview of external braking resistors

2.5 ATEX

The planning of ATEX drives must be check by Getriebebau NORD!

SK 300E	Information	SK 2xxE	Information
Designation Part Number		Designation Part Number	
SK ATX-POT 275142000	ATEX potentiometer 10kΩ	SK ATX-POT 275142000	ATEX potentiometer 10kΩ
SK EU2-ATX1 275141000	ATEX kit for size 1	SK 200E-ATEX-BG1 275274200	ATEX outdoor installation kit for frequency inverters size 1 and 2
SK EU2-ATX2 275141010	ATEX kit for size 2		
-	not available	SK 200E-ATEX-TU4 275274206	ATEX outdoor installation kit for technology options SK TU4-xxx-(C)

Table 12: ATEX overview

The ATEX potentiometer SK ATX-POT (also known under the designation SK EU2-POT) can be used for both frequency inverter series.

The options which are approved for ATEX applications are listed in the manual BU 0200.

2.6 Wall-mounting kit

SK 300E Wall-mounting	Information	SK 2xxE Wall-mounting	Information
Designation Part Number		Designation Part Number	
SK WMK-DA1 275115100	Wall-mounting kit	SK TIE4-WMK-1 275274000	Wall-mounting kit

Table 13: Wall-mounting overview

The adapter kits for motor sizes S 63 and S 71 are identical for both frequency inverter series.



Information

Derating

Due to its construction, the SK 2xxE has different derating characteristics according to the type of mounting (motor-mounted / wall-mounted). Under certain circumstances this requires the selection of a higher power frequency inverter than that which is nominally necessary. Therefore the technical data of the frequency inverter (refer to manual BU0200) must be taken into account.

3. Power and and control terminal connection

3.1 Power connection

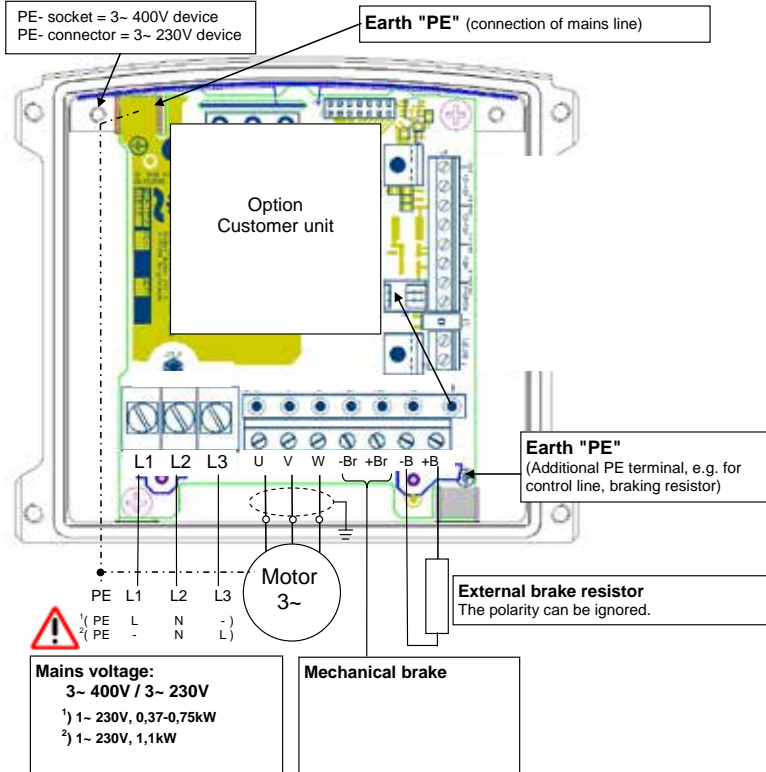
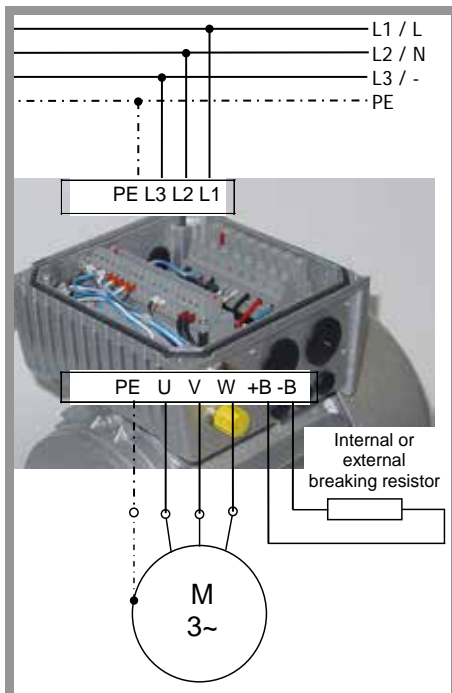

Fig. 1: Assignment of connection unit SK TI 0/x-(C) for SK 300E



Connecting an electro-mechanical brake

SK 2x0E





Terminals 79 (MB+) and 80 (MB-) of the customer interface SK CU4-MBR

SK 2x5E

Terminals 79 (MB+) and 80 (MB-) of the control terminal bar of the frequency inverter

Fig. 2: Assignment of the connection unit SK TI4-x-2xx-x-(C) for SK 2xxE













3.2 Control terminal connection

SK 300E		Function / Meaning	SK 200E		
Terminal bar	Terminal number		Terminal bar	Terminal number	
				SK 2x0E	SK 2x5E
SK TI 0/x-(C) Control connections Connection unit 	21	Digital input 1 Thermistor	SK TI4-x-2xx-x-(C) control terminal bar 	39	
	41	+ 5V supply voltage		38	
	40	0V, GND		40	
	42	+ 15V supply voltage		43 ⁵	44 ⁵
	74	RS 485 interface B (-)	RJ12 control block	2	
	73	RS 485 interface A (+)		1	
	01	Signal relay (error)	SK TI4-x-2xx-x-(C) control terminal bar	1 ⁶	
	02	Signal relay		43 ⁵	44 ⁵
SK CU2-BSC-(C) Customer interface 	11	Reference voltage + 10V	SK TI4-x-2xx-x-(C) control terminal bar	11	-
	12	0V, AGND		12	-
	13	Analog input -	SK TU4-IOE-(C) I/O extension	4	
	14	Analog input +		3	
	22	Digital input 2	SK TI4-x-2xx-x-(C) control terminal bar	22	
	23	Digital input 3		23	
	24	Digital input 4		24	
	42	Supply voltage + 15V		43 ⁵	44 ⁵
SK CU2-STD-(C) Customer interface 	11	Reference voltage + 10V	SK TI4-x-2xx-x-(C) control terminal bar	11	-
	12	0V, AGND		12	-
	14	Analog input 1		14	-
	16	Analog input 2		16	-
	17	Analog output 1	SK TU4-IOE-(C) I/O extension ⁷	9	
				7 (0V-A)	
	22	Digital input 2	SK TI4-x-2xx-x-(C) control terminal bar	22	
	23	Digital input 3		23	
	24	Digital input 4		24	
	25	Digital input 5	SK TU4-IOE-(C) I/O extension	19	
				11 (24V)	
42	Supply voltage + 15V	SK TI4-x-2xx-x-(C) control terminal bar	43 ⁵	44 ⁵	

⁵ 24V supply internal with SK 2x0E, external with SK 2x5E

⁶ Attention: This is not a potential-isolated relay output, but rather only a digital output!

⁷ if there is no SK CU4-MBR with SK 2x0E ...-(C) → use SK CU4-REL / part number 275271011

SK 300E		Function / Meaning	SK 200E		
Terminal bar	Terminal number		Terminal bar	Terminal number	
				SK 2x0E	SK 2x5E
SK BRE3-xxx-xxx Braking resistor 	SK TI 0/x-(C)	External braking resistor	SK BRx4-x-x00-x00 ⁸ Braking resistor 	SK TI4-x-2xx-x-(C)	
	- B	Braking resistor -		- B	
	+ B	Braking resistor +		+ B	
SK TU2-POT-(C) Control connections PotentiometerBox 	Plug contacts	Potentiometer 0...100% switch left-0-right	SK CU4-POT Potentiometer adapter IP 66 	SK 2x0E	SK 2x5E
		24V- supply voltage		43	44
		Enable right (e.g. DIN1)		21	-
		Enable left (e.g. DIN2)		22	-
		Access to AIN +		14	
		Reference voltage 10V		11	
		AGND analog ground		12	
SK ATX-POT ATEX potentiometer 	SK CU2-xxx-(C)	Potentiometer 0...100 % 10 kΩ	SK ATX-POT ATEX potentiometer 	SK 2x0E	SK 2x5E
	11	+ 10V		11	Refer to ⁹
	12	AGND / 0V		12 or 40	Refer to ⁹
	14	Analog input + Analog input 1		14 or 16	Refer to ⁹
SK PAR-2H Parameterbox 	M12 flanged socket on the SK TI 0/x-(C) connection unit 	Parameterisation box / Control unit RS485	SK PAR-3H Parameterbox RJ12 plug with cable 	RJ12 interface on SK 2xxE...-(C) or on the connection unit SK TI4-TU-BUS-(C) 	
SK TU2-PBR-...-(C) Technology unit Profibus DP  <p>Refer to BU 0020 for the relevant technology unit for the connection assignments</p>	Plug contacts M12 round plug connectors B coded 	Profibus DP field bus option	SK TU4-PBR-(C) Profibus DP module Refer to BU 0220 for connection assignments 	Terminal bar SK TI4-TU-BUS-(C)	
		24V -B / Bus supply		1 + 2	
		Profibus DP cable B IN		3	
		Profibus DP cable B OUT		4	
		Profibus DP cable A IN		5	
		Profibus DP cable A OUT		6	
		0V-B / (0V Profibus DP voltage)		7 + 8	
		RTS		9	
+5V B / (5V Profibus DP voltage)	10				

⁸ With the SK 2xxE the internal braking resistor SK BRI4-1-x00-x00 is connected to the same terminals.

⁹ For connection to SK 2x5E ...-(C) frequency inverters either a customer interface mains unit option SK CU4-24V-xxx-B or a SK CU4-IOE IO extension is required!













SK 300E		Function / Meaning	SK 200E		
Terminal bar	Terminal number		Terminal bar	Terminal number	
				SK 2x0E	SK 2x5E
SK TU2-DEV-...-(C) DeviceNet technology unit  Refer to BU 0080 for connection assignments	Plug contacts M12 round plug connectors A coded 	DeviceNet field bus option	SK TU4-DEV-(C) DeviceNet module Refer to BU 0280 for connection assignments  M12 Flanged connector Plug connector 	Terminal bar SK T14-TU-BUS-(C)	
		24V –B / Bus supply		1 + 2	
		DeviceNet High IN		3	
		DeviceNet High OUT		4	
		DeviceNet Low IN		5	
		DeviceNet Low OUT		6	
		0V-B / Data ground Bus		7 + 8	
		SHLD / Bus cable shielding		9	
PE / Bus cable bonding conductor	10				
SK TU2-CAO-...-(C) Technology unit Profibus DP  Refer to BU 0060 for connection assignments	Plug contacts M12 round plug connectors A coded 	CANopen field bus option	SK TU4-CAO-(C) CANopen module Refer to BU 0260 for connection assignments  M12 Flanged connector Plug connector 	Terminal bar SK T14-TU-BUS-(C)	
		24V –B / Bus supply		1 + 2	
		CAN High IN		3	
		CAN High OUT		4	
		CAN Low IN		5	
		CAN Low OUT		6	
		0V-B / Data ground Bus		7 + 8	
		SHLD / Bus cable shielding		9	
PE / Bus cable bonding conductor	10				
SK TU2-ASx-...-(C) AS interface technology unit  Refer to BU 0020 for the relevant technology unit for the connection assignments	Plug contacts M12 round plug connectors A coded 	AS interface field bus option / SK 220E / 225E ...-(C) with integrated ASI interface	SK T14-x-22x-x-(C) control terminal bar Refer to BU 0200 for connection assignments  M12 Flanged connector Plug connector 	SK T14-x-220-x-(C)	SK T14-x-225-x-(C)
		AS-i (+)		84	
		AS-i (-)		85	
		AUX GND		Not required ¹⁰	
		AUX 24V		Not required ¹⁰	
		ASI / Digital input 1		21	
		ASI / Digital input 2		22	
		ASI / Digital input 3		23	
		ASI / Digital input 4		24	
		ASI / Digital output 1		1	
		ASI / Digital output 2		3	- ¹¹

Table 14: Overview of control terminals

¹⁰ The 24V supply is via the yellow AS interface cable (terminals 84 and 85)

¹¹ Con only be implemented with an additional SK TU4-IOE-(C).

More recent software files (GSD, EDS) are required for the field bus technology option SK TU4-xxx-(C). Information about the master data for the device can be found in Section 5. Further software planning information for conversion to the technology options for SK 2xxE frequency inverters can also be found there.

3.2.1 Details of control terminals for connection units and customer interfaces

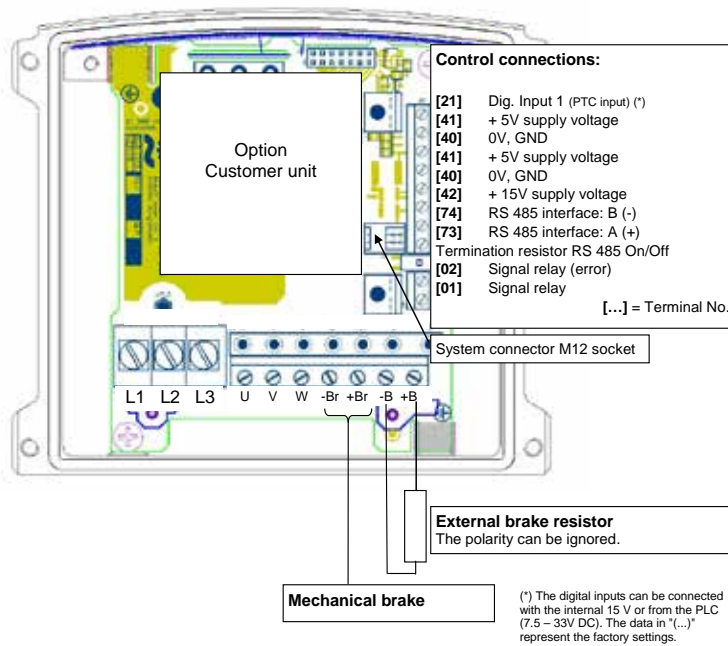

Fig. 3: Control terminals for connection unit SK TI 0/x-(C) for SK 300E

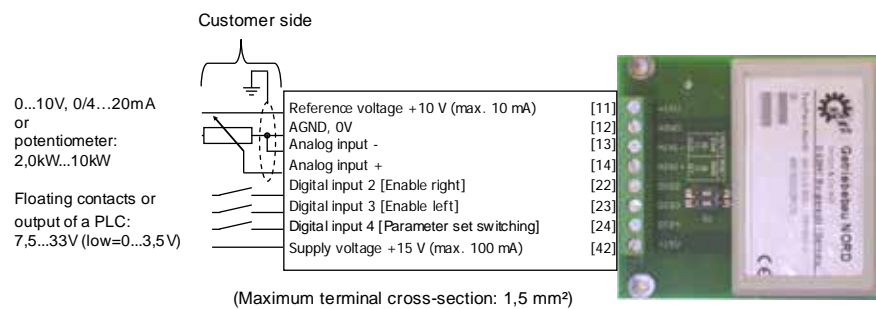

Fig. 4: Control terminals for customer interface SK CU2-BSC-(C) for SK 300E

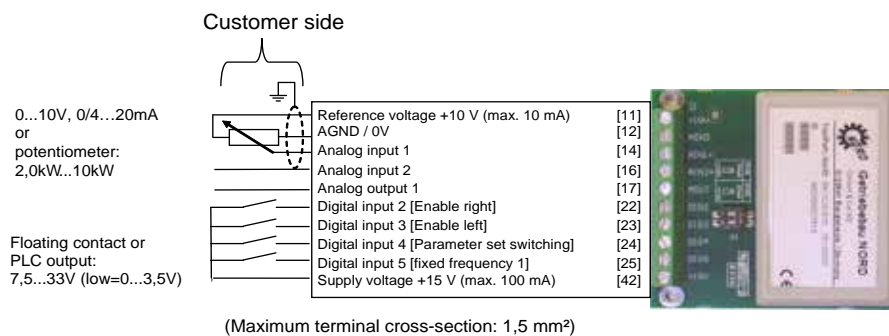
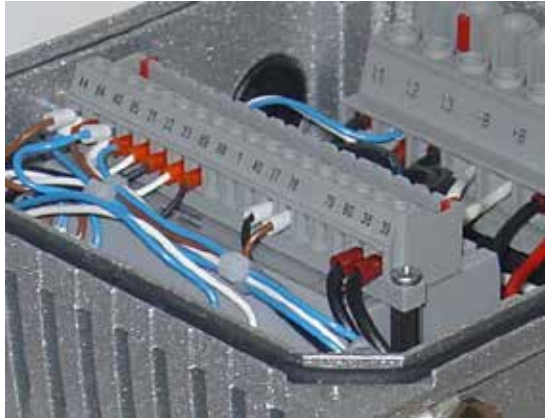

Fig. 5: Control terminals for customer interface SK CU2-BSC-(C) for SK 300E



- ASI: Integrated AS interface
- 24V: 24V power supply
- AGND: Reference potential for analog signals
- GND: Reference potential for digital signals
- DIN: ‚Digital input‘, digital output
- DOUT: ‚Digital output‘, digital output
- MB+/-: Control of electro-magnetic brake
(105V, 180V, 205V)
- TF+/-: Motor thermistor (PTC) connection

Fig. 6: Control terminals of the connection unit SK TI4-x-2xx-x-(C) for SK 2xxE

Connections and functions for SK 2xxE versions depending on configuration level

SK 200E	SK 220E (ASI)	FI type			SK 205E	SK 225E (ASI)
		Labelling		Pin		
24V (internal, output max. 200mA)		43	1		44	24V, external 24V FI supply ¹²
Analog input 1	ASI+, AS interface	14/84	2	44/84	24V, external 24V FI supply	ASI+, AS interface
Analog input 2		16	3	40	GND, reference potential for digital signals	
AGND, Reference potential for analog signals	ASI-, AS interface	12/85	4	40/85	GND	ASI-, AS interface
DIN1 / digital input 1		21	5	21	DIN1 / digital input 1	
DIN2 / digital input 2		22	6	22	DIN2 / digital input 2	
DIN3, digital input 3		23	7	23	DIN3, digital input 3	
DIN4, digital input 4		24	8	24	DIN4, digital input 4	
GND		40	9	40	GND	
DOUT1, digital output 1		1	10	1	DOUT1, digital output 1	
GND		40	11	40	GND	
10V Reference voltage		11	14	-	---	
DOUT2, digital output 2		3	15	79	MB+, electromagnetic brake control	
GND		40	16	80	MB-, electromagnetic brake control	
TF+, motor PTC connection		38	17	38	TF+, motor thermistor (PTC) connection	
TF-, motor thermistor (PTC) connection		39	18	39	TF-, motor thermistor (PTC) connection	

Table 15: Overview of SK 2xxE control terminals

¹² With the use of the AS interface, terminal 44 provides an output voltage (24V, max. 60mA). In this case, no voltage source may be connected to this terminal!

Parameterisation of the customer interface and the field bus technology options can be carried out either via DIP switches or via individual parameters. Further details can be found in the supplementary manuals for the relevant technology option (BU 02x0) or in the manual BU 0200.

Mains unit SK CU4-24V-...-B

With SK 2x5E applications this customer interface can be mounted directly in the connection unit as the mains unit for the 24V supply to the control electronics.



Fig. 7: Customer interface SK CU4-24V-...-B for SK 2x5E

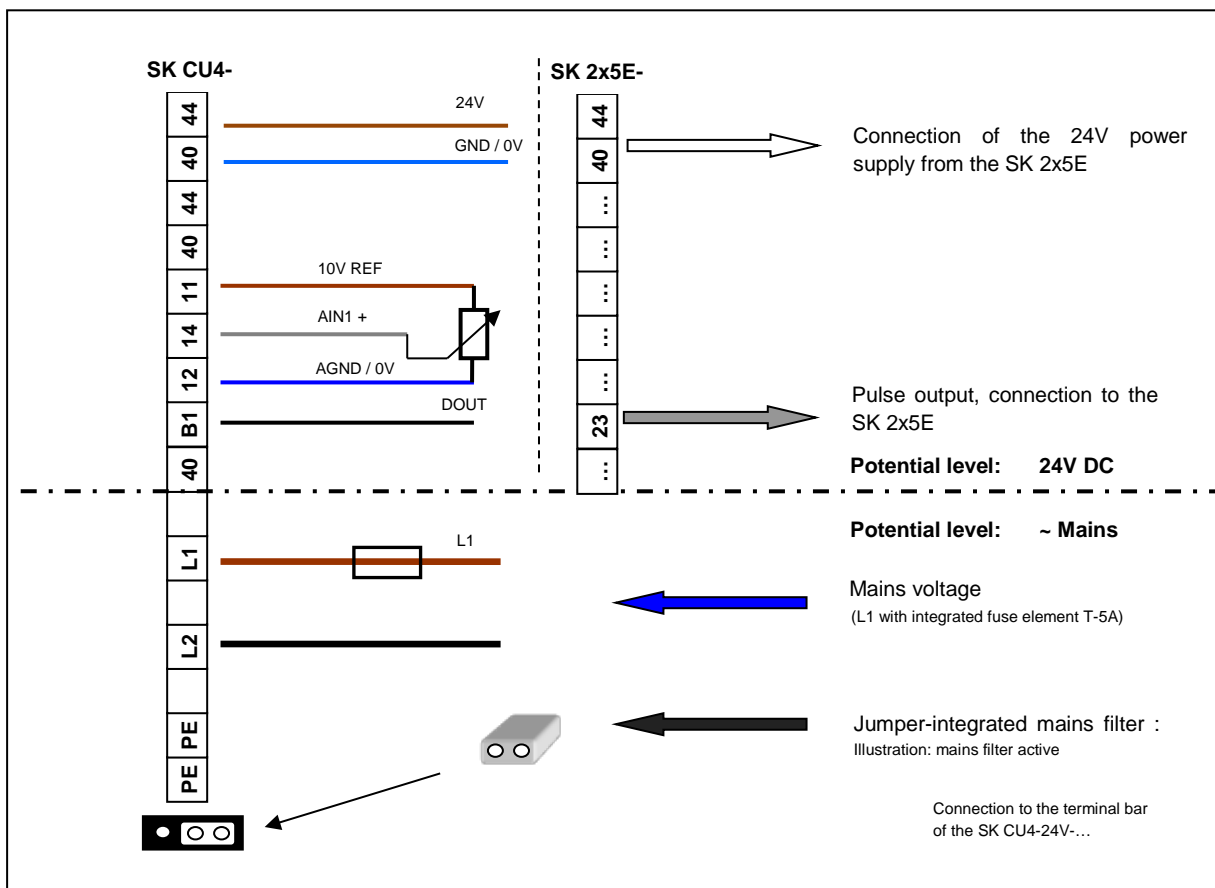

Fig. 8: Control terminals of customer interface SK CU4-24V-...-B for SK 2x5E

Setpoint converter SK CU4-REL

This customer interface can be used instead of the electronic brake rectifier SK CU4-MBR for SK 2x0E applications in which an electro-mechanical brake does not need to be controlled.

The setpoint converter SK CU4-REL enables the digital output signal (DO) of the frequency inverter to be converted into potential-isolated relay outputs.

Also, by means of this customer interface bipolar analog signals can be converted to 0-10V analog signals, which in turn can be processed by the SK 2x0E frequency inverter.



Fig. 9: Customer interface SK CU4-REL for SK 2xxE

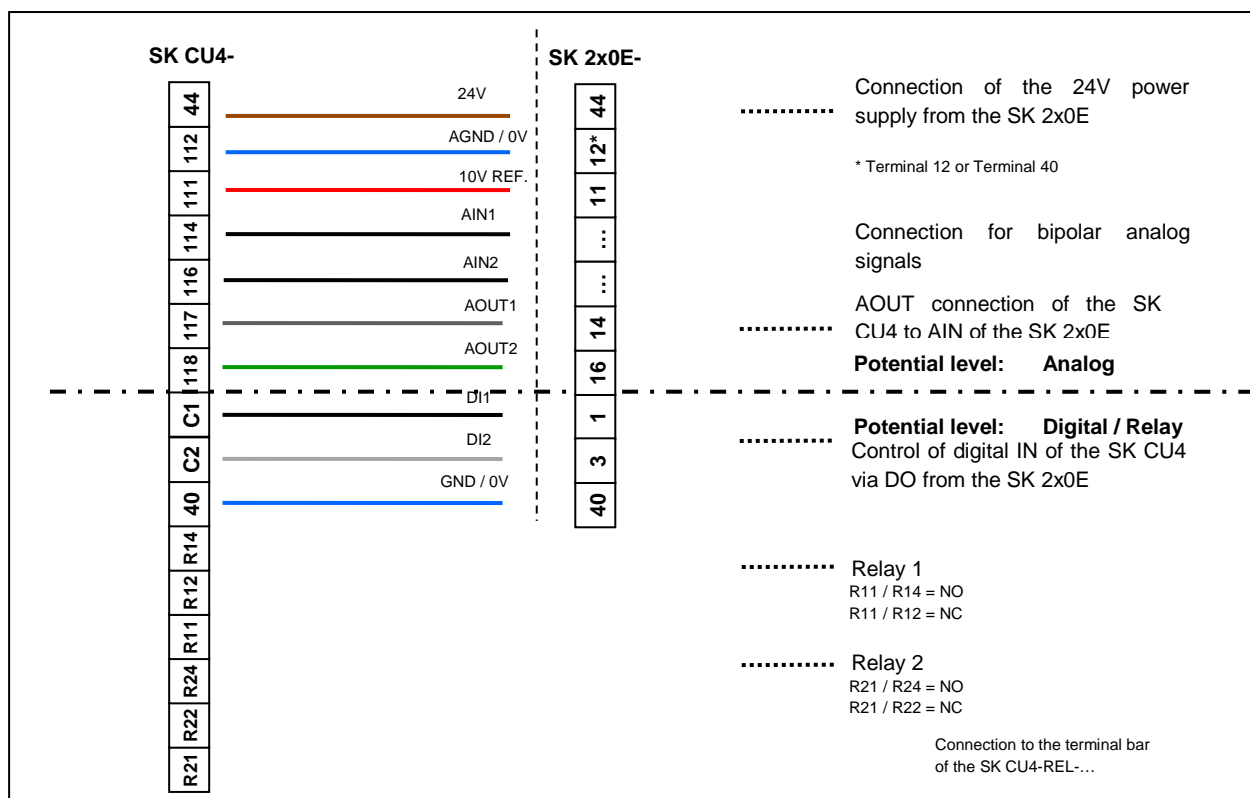

Fig. 10: Control terminals of customer interface SK CU4-REL for SK 2xxE

Electronic brake rectifier, SK CU4-MBR

This customer interface must be used for controlling an electro-magnetic brake in SK 2x0E applications and is mounted directly in the connection unit.



Fig. 11: Customer interface SK CU4-MBR for SK 2xxE

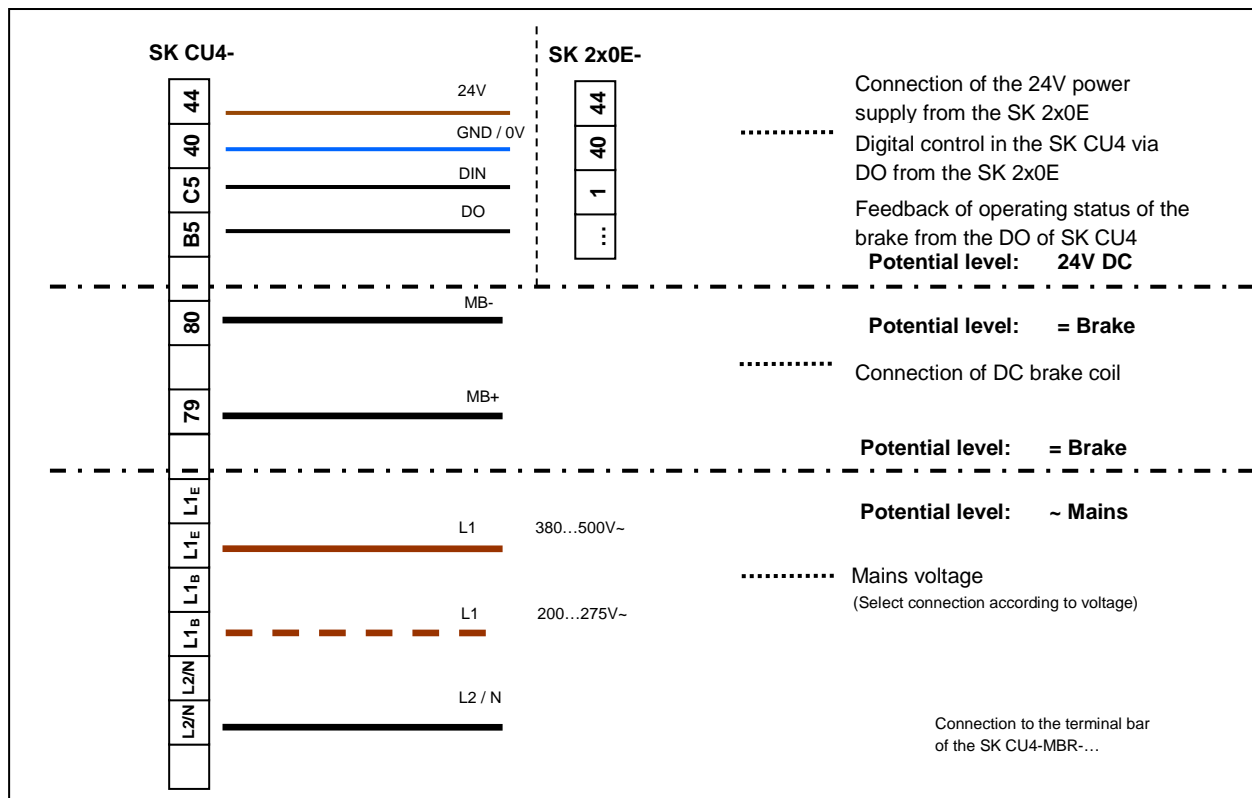

Fig. 12: Control terminals of customer interface SK CU4-MBR for SK 2xxE

3.2.2 Details of control terminals for the technology options

I/O extension SK TU4-IOE-(C)

With SK 2xxE applications, this technology option can be used to connect additional digital and analog IO signals and is mounted on the frequency inverter with an additional connection unit.



Fig. 13: Technology option SK TU4-IOE-(C) and SK T14-TU-BUS for SK 2xxE

Potential level: analog I/O					Potential level: system bus										Potential level: DOs		
Analog IOs					System bus level and digital inputs										Digital outputs		
10V-A	AIN1 +	AIN1 -	0V-A	AOUT	24V	24V (as 11)	0V	0V	DIN 1	0V	24V (as 11)	DIN 2	0V	24V (as 11)	24V 2	DO 1	0V 2
1	3	5	7	9	11	13	15	17	19	21	23	25	27	29	31	33	35
2	4	6	8	10	12	14	16	18	20	22	24	26	28	30	32	34	36
10V-A	AIN2 +	AIN2-	0V-A	PE	24V (as 11)	Sys +	Sys -	0V	DIN 3	0V	24V (as 11)	DIN 4	0V	24V (as 11)	0V 2	DO 2	0V 2

Fig. 14: Control terminals of technology option SK TU4-IOE-(C) for SK 2xxE

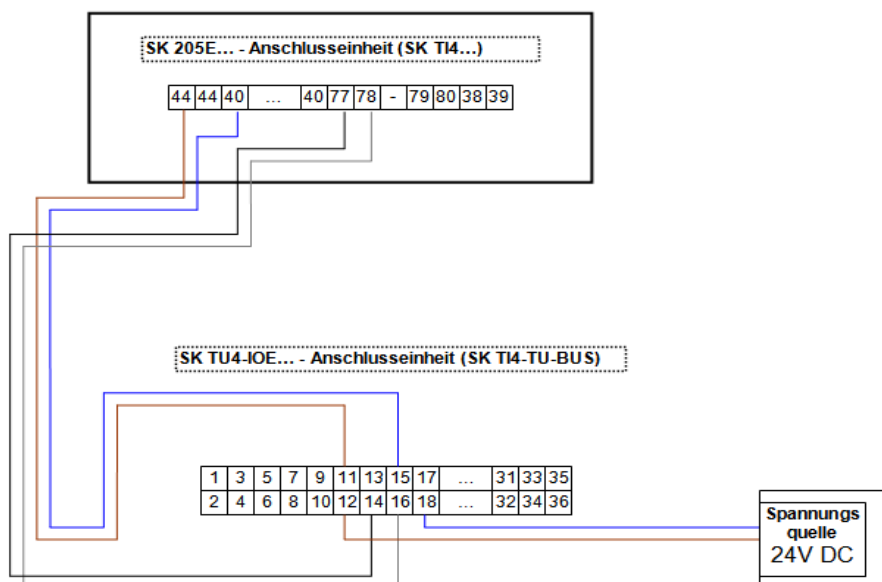



Fig. 15: Connection example for technology option SK TU4-IOE-(C) for SK 2xxE

AS interface SK TU2-ASx-(C) or SK 22xE-...-(C)





	Socket I/O 1	Socket I/O 2
	1 AUX 24V 2 Dig In 1 3 AUX GND 4 Dig Out 1 5 Dig In 3	1 AUX 24V 2 Dig In 2 3 AUX GND 4 Dig Out 2 5 Dig In 4
	Connector PWR	Connector AUX
	1 AS-i (+) 2 AUX GND 3 AS-i (-) 4 AUX 24V 5 n.c.	1 AUX 24V 2 n.c. 3 AUX GND 4 n.c. 5 n.c.

Fig. 16: Technology option SK TU2-ASx-(C) for SK 300E and pin assignment

Terminal 84 / AS +

Terminal 85 / AS -

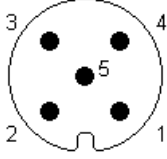
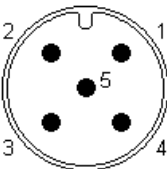
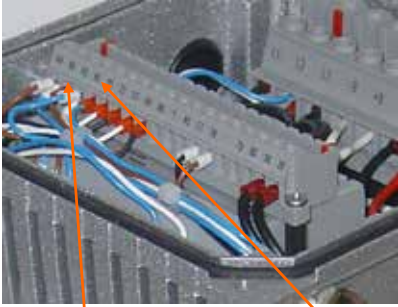
Option: AS Interface M12 flanged plug

Option: Sensor/Actuator M12 flanged plug

Fig. 17: AS interface connection for SK 22xE-...-(C)

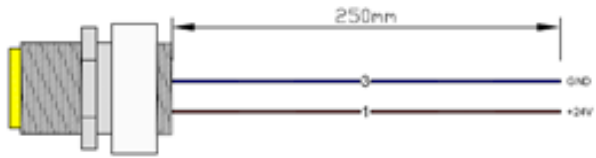

An M12 flanged plug connector, type SK TIE4-M12-AS1 / part number 275274502 is available for connecting the AS interface cable (yellow cable) to the terminals of the control terminal bar of the SK 22xE.

M12 flanged plug to connect an AS interface cable

A-coded, 5-pin		
PIN 1	ASi+ (/+24V)	(brown)
PIN 2	n. c.	
PIN 3	ASi- (/GND)	(blue)
PIN 4	n. c.	
PIN 5	n. c.	
Plastic body in yellow		

M12 flanged sockets type SK TIE4-M12-INI / part 275274503 are available for the connection of sensors and actuators to terminals 84 and 85 of the control terminal bar of the SK 22xE.

M12 flanged plug to connect the CANopen or DeviceNet cable

A-coded, 5-pin		
PIN 1	PE (shield)	(white)
PIN 2	+24V	(brown)
PIN 3	GND	(blue)
PIN 4	CAN-H	(black)
PIN 5	CAN-L	(gray)
Plastic body in gray		

Profibus DP SK TU2-PBR-24V-(C) or SK TU4-PBR-(C)

SK 300E	SK 2xxE	
		
SK TU2-PBR-24V-(C)	SK TU4-PBR-(C)	SK TI4-TU-BUS-(C)

Information about the other two technology options SK TU2- PBR-(C) and SK TU2-KL-...-(C) for the SK 300E can be found in manual BU 0020. Only the 24V version of the SK 300E is described here.

24V dc connection assignments	
M8 pin	Signal
1	24V DC ±25%
3	GND
4	n.c.

An M12 flanged plug connector type SK TIE4-M12-POW / part number 275274507 is available for connecting the 24V supply voltage for the SK TU4-PBR-(C) technology option. See below for the pin assignment.

Fig. 18: M8 socket pin assignment for the 24V supply for SK TU2-PBR-24V-(C)

Standard assignment	
M12 pin	Signal
1	+ 5V
2	A Data
3	GND
4	B Data
5	n. c.

The M12 flanged socket and plug connector type SK TIE4-M12-PBR / part number 275274500 are available for connection the DP Bus cable. See below for the pin assignment.

Fig. 19: M12 socket and plug connector pin assignment for the Profibus DP connection to SK TUx-PBR-

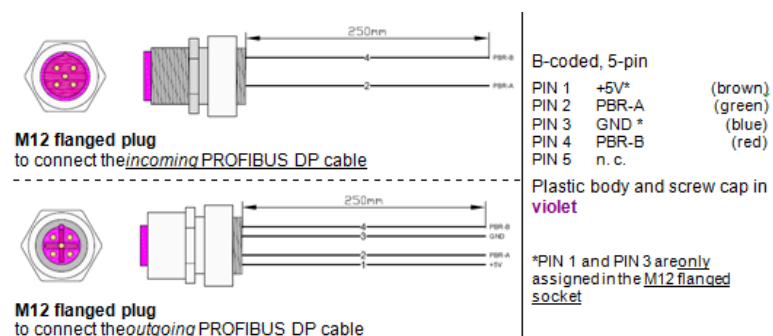

To be connected to the terminals of the control terminal bar of the technology option

SK TU4-PBR-(C), refer to Table 14: Overview of control terminals

Fig. 20: M12 flanged connector SK TIE4-M12-PBR for SK 2xxE

Potential level: field bus

Potential level: system bus

Potential level: DOs

Field bus level PROFIBUS DP					System bus level and digital inputs										Digital outputs		
24V	PB B IN	PB A IN	0V-B	RTS	24V (as for 1)	24V (as for 1)	0V GND	0V GND	DIN 1	0V GND	24V (as for 1)	DIN 2	0V GND	24V (as for 1)	24V 2	DO 1	0V 2
1	3	5	7	9	11	13	15	17	19	21	23	25	27	29	31	33	35
2	4	6	8	10	12	14	16	18	20	22	24	26	28	30	32	34	36
24V (as for 1)	PB B OUT	PB A OUT	0V-B (as for 8)	+5V B	24V (as for 1)	Sys +	Sys -	0V GND	DIN 3	0V GND	24V (as for 1)	DIN 4	0V GND	24V (as for 1)	0V 2	DO 2	0V 2

Fig. 21: Control terminals of technology option SK TU4-PBR-(C) for SK 2xxE

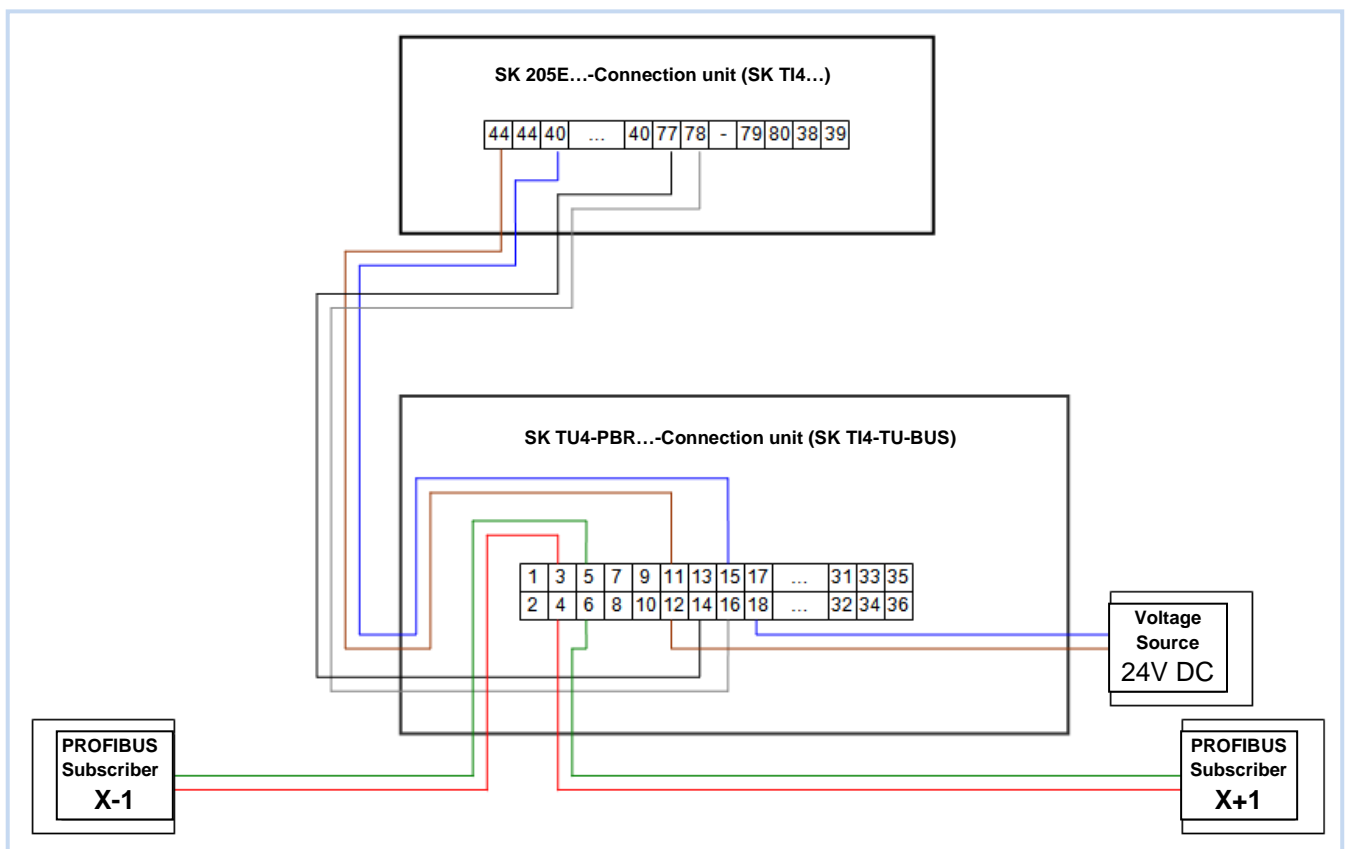

Fig. 22: Connection example for technology option SK TU4-PBR-(C) for SK 2xxE

Information

Field bus systems

In this document a detailed description is given for the field bus systems AS interface and Profibus DP as examples for all field bus systems which are available from NORD. For information about the DeviceNet and CANopen technology options please refer to the relevant manuals (BU0080, BU 0060, BU 0200, or BU 0260 and BU 0280). (www.nord.com)

4. Dimensions

4.1 Frequency inverter - motor mounted

4.1.1 Frequency inverter SK 300E

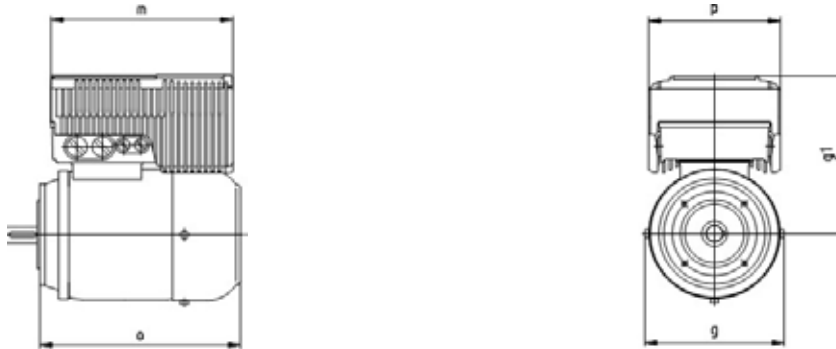

Motor type	Motor output [kW]	Size SK 300E	g	g1	m	o	p	Weight (FI only)
71 L/4, /2	0.37 / 0.55	Size 1	138	194	214	214	156	4.0
80 S/4 /2	0.55 / 0.75		156	189	214	236	156	
90 S/6	0.75		176	194	214	276	156	
80 L/2	1.1	Size 2	156	211	283	236	196	8.4
80 L/40	1.1		156	211	283	236	196	
90 S/2, /4	1.5 / 1.1		176	216	283	276	196	
90 L/4, /6	1.5 / 1.1		176	216	283	276	196	
100 L/6	1.5		194	234	283	306	196	
100L/4	2.2		194	234	283	306	196	

all dimensions in [mm] and approx. weights in [kg]

Table 16: Dimensions of SK 300E (230V/240V) motor-mounted

Motor type	Motor output [kW]	Size SK 300E	g	g1	m	o	p	Weight (FI only)
80 S/4	0.55	Size 1	156	189	214	236	156	4.0
80 L/2, /4	1.1 / 0.75		156	189	214	236	156	
80 L/40	1.1		156	189	214	236	156	
90 S/2, /4, /6	1.5 / 1.1 / 0.75		176	194	214	276	156	
90 L/4, /6	1.5 / 1.1		176	194	214	276	156	
100 L/6	1.5		194	212	214	306	156	
100L/4	2.2	Size 2	194	234	283	306	196	8.4
100L/40	3.0		194	234	283	306	196	
112M/4	4.0		218	244	283	326	196	

all dimensions in [mm] and approx. weights in [kg]

Table 17: Dimensions of SK 300E (400V/480V) motor-mounted

4.1.2 Frequency inverter SK 2xxE

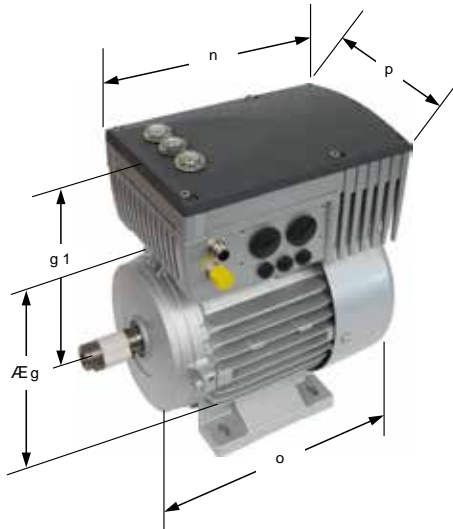

Size		Housing dimensions SK 2xxE / Motor					Weight of SK 2xxE without motor Approx. [kg]
FI	Motor type	Æg	g 1	n	o	p	
Size I	Size 71 *	145	201	236	214	156	3.0
	Size 80	165	195		236		
	Size 90 S / L	183	200		251 / 276		
	Size 100	201	209		306		
Size II	Size 80	165	202	266	236	176	4.1
	Size 90 S / L	183	207		251 / 276		
	Size 100	201	218		306		
	Size 112	228	228		326		
all dimensions in [mm] * incl. adapter and gasket (11015410, 13097000)							

Table 18: Dimensions of SK 2xxE, motor-mounted

4.2 Frequency inverter - wall-mounting

4.2.1 Frequency inverter SK 300E with WMK-DA1

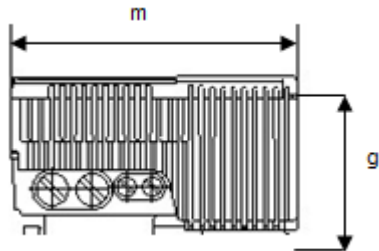

SK 300E side view



SK 300E with wall-mounting kit SK WMK-DA1 and HARTING plug connector

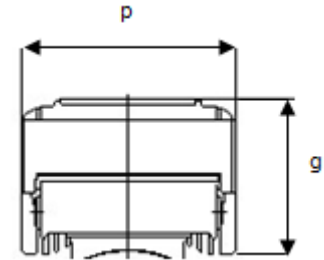

SK 300E front view

Motor output [kW]	Size SK 300E	g	m	p	Weight(FI only)
230V/240V à 0.37 - 0.75 400V/480V à 0.55 – 1.5	Size 1	155	215	160	4.0
230V/240V à 1.1 – 2.2 400V/480V à 2.2 - 4	Size 2	185	283	200	8.4

all dimensions in [mm] and approx. weights in [kg]

Table 19: Dimensions of SK 300E, wall-mounted

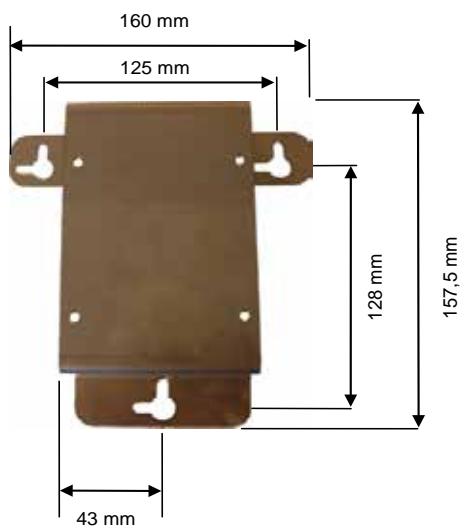
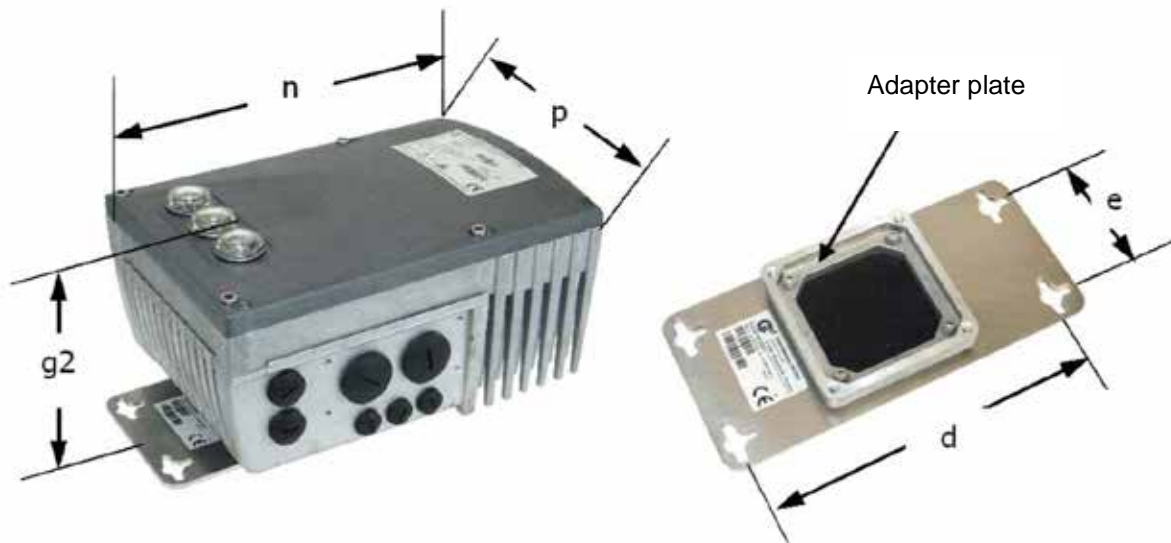

Fig. 23: Dimensions of wall-mounting kit SK WMK-DA1

4.2.2 Frequency inverter SK 2xxE with SK TIE4-WMK-1



Device type Size Part Number	Housing dimensions SK 2xxE			Wall-mounting kit SK TIE4-WMK-1			total weight Approx. [kg]
	g2	n	p	d	e	∠	
Size I à SK TIE4-WMK-1 275 274 000	130.5	236	156	180	64	5.5	3.5
Size II à SK TIE4-WMK-1 275 274 000	137.5	266	176				

Table 20: Dimensions of SK 2xxE, wall-mounted

4.3 Options

4.3.1 Frequency inverter technology unit (SK 2xxE)

With the SK 2xxE a technology unit can be mounted on the right or left side of the connection unit. This can also be mounted decentrally using a wall-mounting bracket.



Fig. 24: Dimensions of wall-mounting kit SK TIE4-WMK-TU and SK TU4-CAO-(C) technology option

4.3.2 Braking resistors (external braking resistors)

If the SK 300E which is to be replaced is not equipped with a braking resistor, in general an internal brake resistor type SK BR14 must be provided for the SK 2xxE. However, if a braking resistor was fitted on the SK 300E, for the SK 2xxE a corresponding braking resistor type SK BRE4 must be used in place of the internal braking resistor SK BR14.

SK 300E-...-B(-C)	SK BR3-...	SK 2xxE-...-A(-C)	SK BRE4-...	Part. No.	[Ω]	[W]
...370-323... to ...221-323...	... 82/200-TI 0/1 ... 82/200-TI 0/2	...370-123... to ...111-123...	...2-100-200	275273105	100	200
		...370-323... to ...221-323...	...2-200-200	275273108	200	200
...550-340... to ...151-340...	... 120/100-TI 0/1 ... 120/100-TI 0/2	...550-340... to ...151-340...	...2-400-100	275273012	400	100
...221-340... to ...401-340...	... 82/200-TI 0/1 ... 82/200-TI 0/2	...221-340... to ...401-340...	...2-200-200	275273108	200	200

Table 21: Assignment of external braking resistors for SK 2xxE compared with SK 300E

Resistor type SK BR3-...	A	B	C	D
... 120/100-TI 0/1	150	160	65	75
... 82/200-TI 0/1	255	160	65	75
... 120/100-TI 0/2	150	160	75	82
... 82/200-TI 0/2	255	160 </td <td>75</td> <td>82</td>	75	82

All dimensions in [mm]

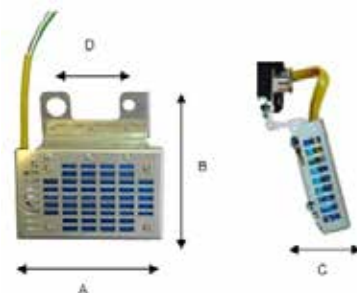

Table 22: Dimensions of external braking resistors for SK 300E

Resistor type SK BRE4-...	A	B	C	Fixing dimensions		
				d	e	Æ
...1-100-100 ...1-200-100 ...1-400-100	150	178	61	83	32	4.3
...2-100-200 ...2-200-200	255	178	61	83	32	4.3

All dimensions in [mm]

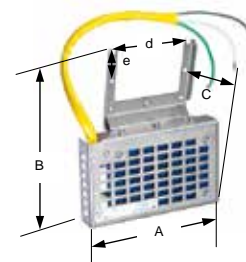

Table 23: Dimensions of external braking resistors for SK 2xxE

5. Additional information and documents

In addition to this document, data sheets, manuals, mounting instructions and flyers are available for the products described.

Manuals

Basic information about the frequency inverters can be found in the relevant manuals for the frequency inverter series (e.g. **BU 0200** for SK 2xxE).

Further information concerning special technology options (e.g. the field bus module) is included in the relevant supplementary operating instructions (e.g. **BU 0220** for Profibus DP). Information about the control and parameterisation units can be found in manual BU0040.

Installation and conversion instructions

Installation instructions are available for the installation of the SK 2xxE frequency inverter. This is available on request from your Getriebebau NORD contact partner.

Supplementary conversion instructions, **BU 0320** are available in Internet for the conversion of NORDAC trio TR frequency inverters to the SK 2xxE series.

Data sheets

Data sheets for various additional components (e.g. mains filters) can be obtained from www.nord.com.

Flyers

The product flyer for decentralised drive technology, **F 3020** provides an overview of the technical data, features and accessories for the SK 2xxE series.

In addition, special flyers are available for pump and fan applications (**S 3021**) and applications for conveyor technology (**S 3022**).

NORDCON PC software

The NORDCON PC software can be used for the control and parameterisation of NORD frequency inverters. SK 2xxE frequency inverters and the associated technology options are currently implemented as of version 02.01.02.02.

NORD software files for optional modules

The appropriate software files (GSD, EDS) are available for download in Internet for the field bus options which are available for the relevant field bus applications. The software files for the SK 2xxE frequency inverter series are different to those for the SK 300E.

The following points must be noted for planning the software for automation systems (SPS, CANopen Master, etc.) when changing to the technology options for the SK 2xxE:

- Device master files (GSD and EDS) for SK TU4-xxx-(C) technology options
- PPO types 2 and 4: the setpoint and actual values 2 and 3 are transposed in the process data
- Changes for the parameter values in the parameter channel (array parameters, parameter structure, etc.)

Information

www.nord.com

The latest versions of the documentation (manuals, flyers, NORDCON software etc.) can be downloaded in Internet from the NORD homepage (www.nord.com).

List of illustrations

Fig. 1: Assignment of connection unit SK TI 0/x-(C) for SK 300E	15
Fig. 2: Assignment of the connection unit SK TI4-x-2xx-x-(C) for SK 2xxE	15
Fig. 3: Control terminals for connection unit SK TI 0/x-(C) for SK 300E	19
Fig. 4: Control terminals for customer interface SK CU2-BSC-(C) for SK 300E	19
Fig. 5: Control terminals for customer interface SK CU2-BSC-(C) for SK 300E	19
Fig. 6: Control terminals of the connection unit SK TI4-x-2xx-x-(C) for SK 2xxE	20
Fig. 7: Customer interface SK CU4-24V-...-B for SK 2x5E	21
Fig. 8: Control terminals of customer interface SK CU4-24V-...-B for SK 2x5E	21
Fig. 9: Customer interface SK CU4-REL for SK 2xxE	22
Fig. 10: Control terminals of customer interface SK CU4-REL for SK 2xxE	22
Fig. 11: Customer interface SK CU4-MBR for SK 2xxE	23
Fig. 12: Control terminals of customer interface SK CU4-MBR for SK 2xxE	23
Fig. 13: Technology option SK TU4-IOE-(C) and SK TI4-TU-BUS for SK 2xxE	24
Fig. 14: Control terminals of technology option SK TU4-IOE-(C) for SK 2xxE	24
Fig. 15: Connection example for technology option SK TU4-IOE-(C) for SK 2xxE	24
Fig. 16: Technology option SK TU2-ASx-(C) for SK 300E and pin assignment	25
Fig. 17: AS interface connection for SK 22xE-...-(C)	25
Fig. 18: M8 socket pin assignment for the 24V supply for SK TU2-PBR-24V-(C)	26
Fig. 19: M12 socket and plug connector pin assignment for the Profibus DP connection to SK TUx-PBR-	26
Fig. 20: M12 flanged connector SK TIE4-M12-PBR for SK 2xxE	26
Fig. 21: Control terminals of technology option SK TU4-PBR-(C) for SK 2xxE	27
Fig. 22: Connection example for technology option SK TU4-PBR-(C) for SK 2xxE	27
Fig. 23: Dimensions of wall-mounting kit SK WMK-DA1	30
Fig. 24: Dimensions of wall-mounting kit SK TIE4-WMK-TU and SK TU4-CAO-(C) technology option31	

List of tables

Table 1: Overview of components	4
Table 2: Overview of frequency inverters - Power levels	4
Table 3: Overview of connection units	4
Table 4: Overview of SKL 2xxE performance levels	5
Table 5: 1 phase 230V/240V ~	6
Table 6: 3 phase 230V/240V ~	7
Table 7: 3 phase 400V/480V ~	9
Table 8: Overview of options 1	10
Table 9: Overview of options 2	11
Table 10: Overview of AS interface options	12
Table 11: Overview of external braking resistors	13
Table 12: ATEX overview	14
Table 13: Wall-mounting overview	14
Table 14: Overview of control terminals	18
Table 15: Overview of SK 2xxE control terminals	20
Table 16: Dimensions of SK 300E (230V/240V) motor-mounted	28
Table 17: Dimensions of SK 300E (400V/480V) motor-mounted	28
Table 18: Dimensions of SK 2xxE, motor-mounted	29
Table 19: Dimensions of SK 300E, wall-mounted	30
Table 20: Dimensions of SK 2xxE, wall-mounted	31
Table 21: Assignment of external braking resistors for SK 2xxE compared with SK 300E	32
Table 22: Dimensions of external braking resistors for SK 300E	32
Table 23: Dimensions of external braking resistors for SK 2xxE	32



www.nord.com/locator

Headquarters:

Getriebebau NORD GmbH & Co. KG

Getriebebau-Nord-Straße 1

22941 Bargteheide, Germany

Fon +49 (0) 4532 / 289-0

Fax +49 (0) 4532 / 289-2253

info@nord.com, www.nord.com

Member of the NORD DRIVESYSTEMS Group

