

## Drive technology in end-of-line packaging

Advantages of decentralized drive solutions with controlled frequency inverters

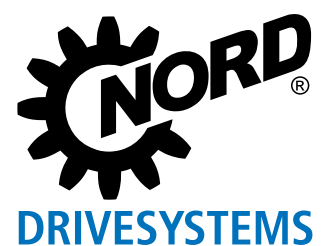

# Foreword

---

Drives with centrally controlled servo motors are commonly used in end-of-line packaging. However, in applications with large inertia or long travel distances – for example palletizing, stabilizing or handling – they are usually not mandatory. Decentralized drive solutions, such as those with controlled asynchronous motors, are an efficient and economical alternative in this context. They achieve similar kinematic properties and, due to their higher internal inertia, ensure better regulation and motion control with heavy loads. The use of decentralized frequency inverters with “closed-loop control” also results in enormous cost savings. Depending on the system type and application, cost benefits of up to 50% are possible.

# End-of-Line Packaging

## At the end of the production line

End-of-line packaging defines the final step in the packaging process and thus the end of the production line. Here, the products and goods are packaged ready for sale and prepared for transport to the customer. Heavy pallets with bags, boxes, and containers are the primary items being moved. End-of-line packaging differs from primary and secondary packaging primarily in terms of heavier loads, longer movement distances, as well as lower precision and dynamics requirements. Additionally, there is usually more installation space available in the final packaging area.

## Processes and machines

Specific distinctions are made between the processes of wrapping, strapping, palletizing, and conveying. Conveyor systems are not specific to end-of-line packaging, however similar forms can also be found in primary and secondary packaging.

### Machines in end-of-line packaging:

- ▶ Wrapping machines: pallet securing by film wrapping (ring, arm, turntable, and stretch hood wrapping machines)
- ▶ Strapping machines: pallet securing by strapping (vertically and horizontally)
- ▶ Palletizing machines: layer, gantry, and column palletizing machines, linear robot, pallet lift
- ▶ Conveyor systems for pallet feeding: upstream and downstream roller conveyor belts, and pallet turntables

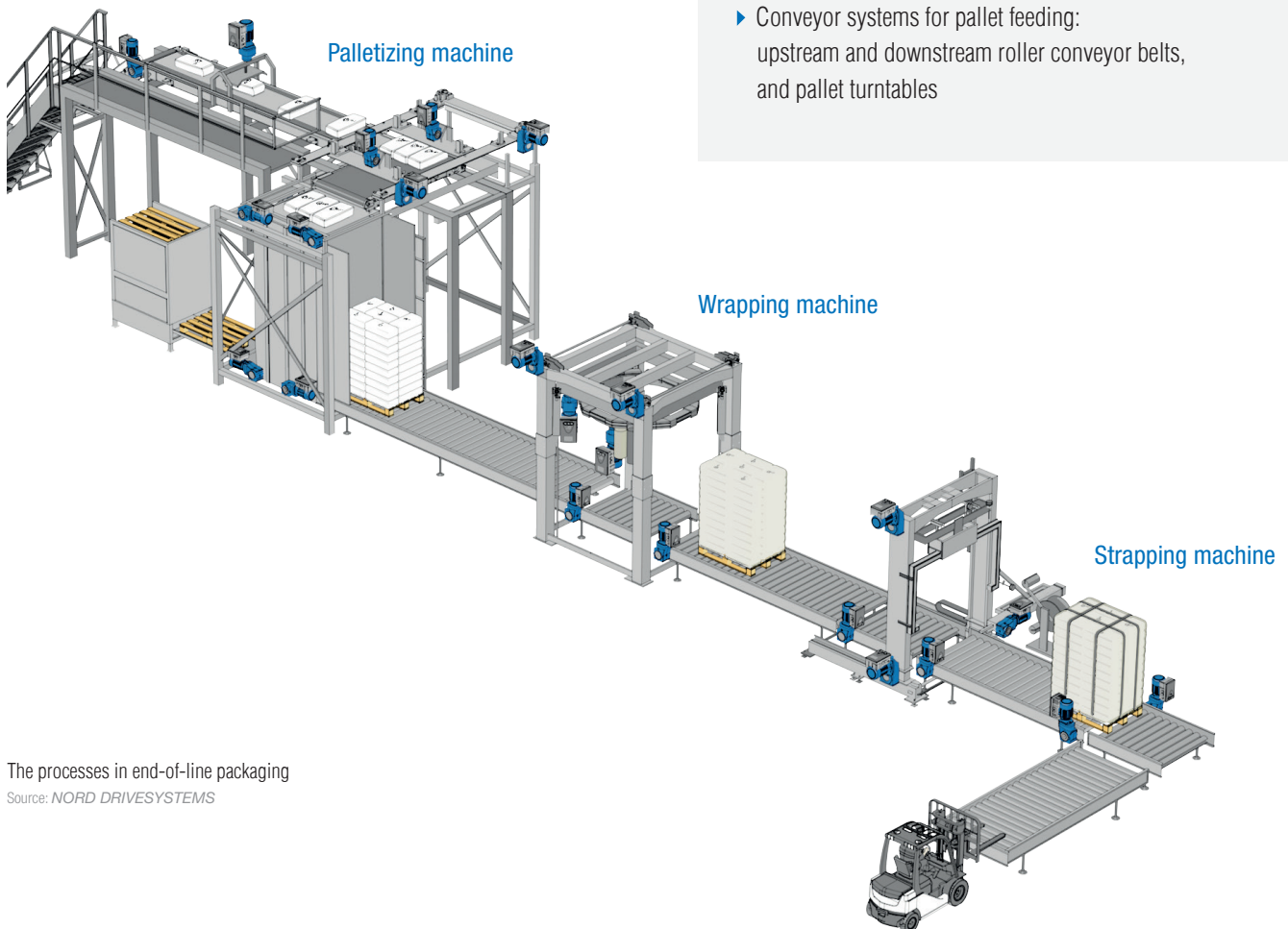

The processes in end-of-line packaging

Source: *NORD DRIVESYSTEMS*

# End-of-Line Packaging

Final packaging applications place great demands on economic efficiency, reliability, and compactness, as well as compliance with applicable safety standards. In terms of dynamics and precision, a more differentiated picture emerges. While palletizing machines place great demands, wrapping and strapping machines are not as demanding in comparison.

The requirements of the three basic processes in end-of-line packaging from the perspective of drive technology:

	Wrapping	Strapping	Palletizing
Dynamics	low	low	high
Precision	low	low	high
Torques	high	low	medium to high

### Growth industry in constant change

The packaging industry is experiencing an average annual sales growth of 4 – 6% worldwide and is subject to constant change. Product and process innovations ensure sustainability and competitiveness. Cost efficiency, sustainability, resource conservation, and digitalization are the most important drivers here. End-of-line packaging is still characterized by conventional rigid production lines, however, demands on productivity and flexibility increasingly call for modular and decentralized concepts. Issues such as energy consumption, space requirements, and handling also play an increasing role, and drive technology can make an important contribution to this.

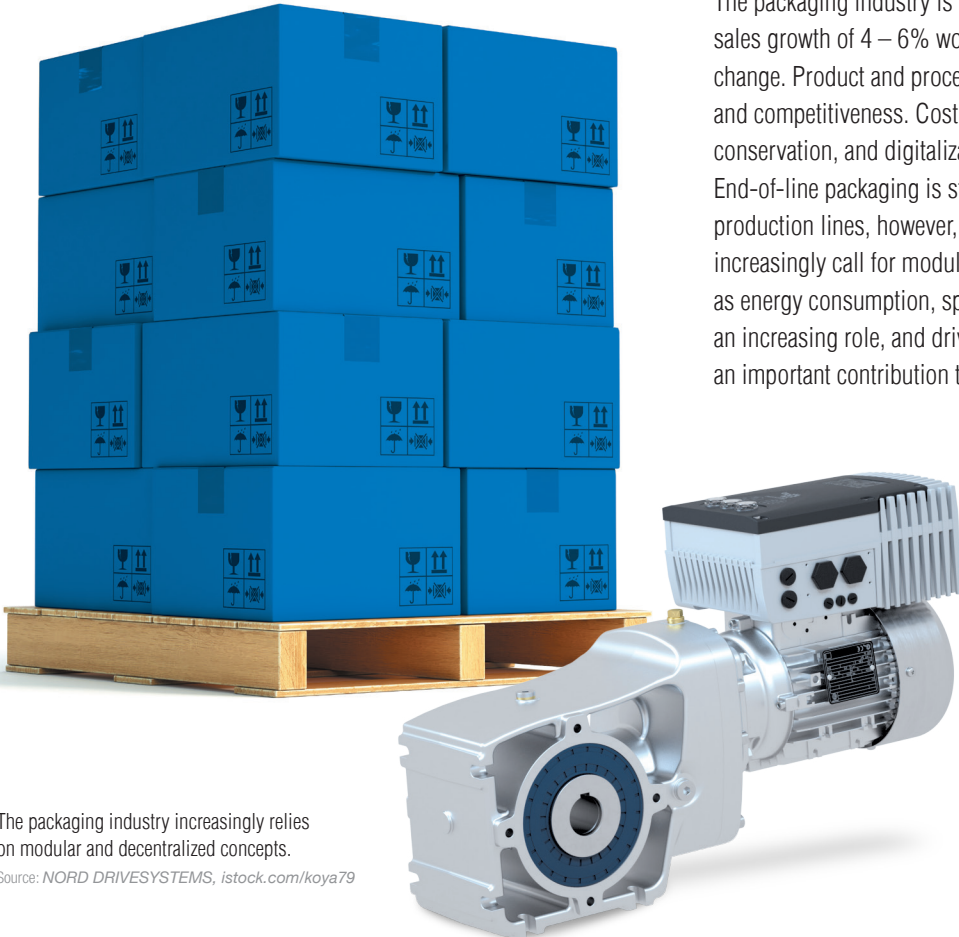

The packaging industry increasingly relies on modular and decentralized concepts.  
 Source: NORD DRIVESYSTEMS, istock.com/koya79

# Drive technology in end-of-line packaging

---

## Lifting, rotating, and positioning

Electrical drive systems are of essential importance to end-of-line packaging. They bring automated machines and systems into motion and make a major contribution to cost-efficient, precise, and reliable processes. Wherever pallets need to be lifted, rotated, positioned, or moved, they need to be transported using electrical drive technology. For example, with linear drives in Cartesian systems such as gantry robots, palletizing machines, pushers, and pallet lifts. Rotation axes in turntables and gripping systems are also moved by electrical drive systems.

## Requirements for the drive technology

End-of-line packaging is highly price-driven, therefore economical aspects are a priority. The drives must be absolutely reliable and guarantee smooth operation with minimal downtime as the primary objective. If a replacement is necessary after inspection or for routine maintenance, inspection and maintenance, it should be possible to carry out the process quickly and easily.

The industry also demands system solutions. Complete drive systems consisting of motor, gear unit, and controlled frequency inverter make the integration and commissioning significantly easier. The ability to purchase everything from a single source saves time, money, and effort. All drive components are optimally matched to each other as well as to the customer's individual application and have all required mechanical and electronic interfaces for seamless integration into the machine and existing production processes.

### Drive technology requirements in end-of-line packaging:

- ▶ Economic operation: achieves cost savings
- ▶ Maintenance-friendly: easy, quick replacement
- ▶ Reliability: long service life and low downtimes
- ▶ System solutions from a single source (motor, gear unit, and frequency inverter)
- ▶ Easy integration into the machines mechanical and electronic interfaces
- ▶ Safety functions
- ▶ Compact design

## Is the dominance of servo technology justified?

In packaging technology, conventional servo drives are used in the majority of cases, or more precisely, with drive solutions centrally controlled synchronous servo motors. The complex and expensive technology has its justification in primary and secondary packaging, as exact positioning and high dynamics are required. In many end-of-line packaging applications, however, synchronous servo drive systems are not required. Due to the high masses and forces, the processes there are less dynamic. Additionally, many servo functions such as synchronization of several axes are rarely needed.

Controlled asynchronous drive systems are often more efficient and significantly more economical – in particular if they are operated with decentralized frequency inverters. Although the first decentralized concepts are now also available in the servo sector, the drive electronics for synchronous servo drives are still mainly housed in the control cabinet. The consequence: unnecessary high costs.

# The role of servo technology

---



During the wrapping process, pallets are wrapped with film. This provides stability.

Source: [istock.com/Foto-Video-Studio](https://www.istock.com/Foto-Video-Studio)

## What the packaging industry means by a servo drive

The packaging industry understands a servo drive as a drive based on a permanently excited motor (PMSM) with a slim design and low inertia that provides high speeds, high torques, high dynamics, and high power density. In permanently excited synchronous motors, the rotor is driven synchronously by the rotating field of the stator with applied permanent magnets, which causes a synchronous movement to the applied rotating field frequency and, among other things, ensures very good control properties.

## Asynchronous motors in end-of-line packaging

Synchronous servo drives are considered the ultimate in the packaging industry due to their low internal inertia (low rotor inertia), good control characteristics with low external inertia, high dynamics, and their high torque, however there are other solutions. Due to their specific characteristics, asynchronous motors are an ideal solution for the specific requirements in end-of-line packaging – heavy loads, high forces, long movement distances, slow movements, dynamic load changes – and represent an efficient and economical solution to drives with centrally controlled synchronous servo motors.

# Decentralized drive technology with controlled frequency inverters in end-of-line packaging

## Great regulation and motion control with heavy loads

Compared to commonly used drives with synchronous servo motors with or without a gear unit with large ratios, asynchronous geared motors offer advantages in end-of-line packaging. Asynchronous motors have higher inertia in the rotor due to their design. When combined with a controlled frequency inverter, they ensure better regulation and motion control with high external inertia, i.e. heavy loads. Asynchronous motors have a clear advantage, particularly when moving heavy loads. Additionally, they enable the highest process stability. An overload reserve of 100 – 300% further ensures high operational reliability.

## More economic efficiency

Decentrally controlled asynchronous drive solutions are more cost effective to purchase than central synchronous servo drive systems. They also offer economic advantages in terms of installation, maintenance, service life, and space requirements. Further cost reductions are realized from operation with decentralized frequency inverter that utilizes an integrated PLC. These drive systems provide the opportunity to directly connect and control surrounding sensors and actuators, as well as evaluate the signals. This reduces wiring efforts and saves control capacities in the control cabinet.

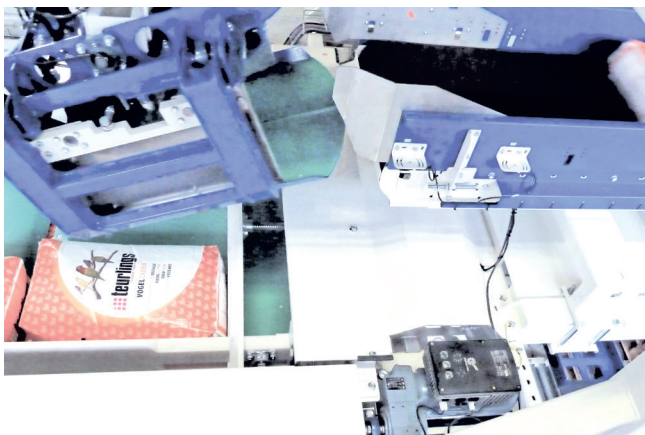

Strapping machine

Quelle: NORD DRIVESYSTEMS



Fully automatic machine in end-of-line packaging

Quelle: NORD DRIVESYSTEMS

Depending on the system type and application, savings can amount to up to 50%. A decentralized solution can also reduce data traffic on the higher-level bus system and solve independent applications via the integrated PLC. All common packaging automation interfaces can be integrated, saving time and money on commissioning costs. The PLC can also take over the complete control of stand-alone machines, eliminating the need for an expensive, add-on control system.

## Closed loop control with encoder feedback

Closed loop control is not a typical field of application for asynchronous motors, however when combined with an encoder, the required controllability or feedback of position and speed is met. The encoder ensures high speed quality with changing loads, speeds, and/or positions, as well as dynamic movements with high precision.

# Decentralized drive technology with controlled frequency inverters in end-of-line packaging

## Advantages of asynchronous motors in end-of-line applications

- ▶ Low procurement costs
- ▶ Comparable kinematic properties to synchronous servo motors
- ▶ Better regulation and motion control with high external inertia (for example, pallet lift), particularly with fast movements and dynamic load changes
- ▶ High operational reliability due to overload capacities of 200 – 300%
- ▶ Reliable operation at high speeds
- ▶ High compatibility due to a wide range of standard options
- ▶ Low installation and maintenance effort
- ▶ High level of process stability

## Servo and asynchronous geared motor in comparison

If you compare the most important characteristics of servo and asynchronous geared motors, it becomes clear: in the specific application of end-of-line packaging where heavy loads are commonplace, drive systems with asynchronous motors have many advantages. They feature better regulation and motion control with lower gear ratios of heavy masses, are more cost effective to purchase, require less space, and are also less complicated in terms of commissioning, installation, and maintenance. The lower values regarding precision and dynamics are not a disadvantage, as end-of-line packaging requirements are significantly lower than in primary and secondary packaging. Additionally, the increased inertia of the drive reduces vibrations and increases control.

## Wide range of applications

Asynchronous drive systems are suitable for a wide range of applications in end-of-line packaging – be it handling, palletizing, or transport securing. Overall, they achieve comparable kinematic properties to synchronous servo drives with reduced costs, especially when used in connection with decentralized drive electronics.

		Servo geared motor	Asynchronous geared motor
Investment costs	●●● = inexpensive ● = expensive	●	●●●
Space requirements in the control cabinet	●●● = little ● = much	●	●●●
Precision	●●● = high ● = low	●●●	●●
Dynamics	●●● = high ● = low	●●●	●●
Controllability with heavy loads	●●● = high ● = low	●●	●●●
Installation effort (required knowledge & higher cabling effort)	●●● = low ● = high	●	●●●
Maintenance effort (Availability of spare parts)	●●● = low ● = high	●●	●●●

Servo geared motor and asynchronous geared motor in comparison

Source: NORD DRIVESYSTEMS



# Decentralized drive technology: Greater flexibility, lower costs

## Decentralized drive technology is on the rise

In end-of-line packaging, drive electronics are mainly housed in the control cabinet. There are historical reasons for this, but it is also due to the fact that decentralized servo controllers have been the standard to date. The future, however, belongs to modular concepts with decentralized drive technology. Here, the drive tasks are distributed to individual, intelligent components in the field. They are installed where they are needed – i.e. on or close to the motor.

## Reduced costs with more efficiency at the same time

For users, decentralization of drive technology means faster commissioning and simplified maintenance and repair processes. Costs can be reduced considerably on the software side, such as with factory pre-configurations. With a modular concept, the drive also maintains maximum flexibility, as changes to the system architecture can be made at any time without large structural modifications, and additional drives can be easily added later without changes to the control cabinet. As a result, costs are reduced, drives are more efficient, and scalability is increased.

## Smaller control cabinet with lower air-conditioning requirements

The decentralized automation concept leads to a more cost-effective, uncomplicated control cabinet construction. If the frequency inverters are installed directly in the field, less space is required in the control cabinet.

### Advantages of decentralized drive technology:

- ▶ Control cabinet can be smaller or eliminated altogether
- ▶ Minimal wiring and cabling work
- ▶ Simple maintenance
- ▶ Rapid commissioning thanks to factory pre-configuration
- ▶ Modifications and extensions to the system design easily possible at any time
- ▶ Reduced costs for the system design
- ▶ Reduced system complexity
- ▶ Increased efficiency of the entire drive system
- ▶ Can be integrated into all automation architectures

As a result, it can be smaller or in some cases eliminated altogether, as an integrated PLC and connections for drive-related sensors are also available. With no frequency inverter as an extra source of heat in the control cabinet, costs for air conditioning are also reduced. This can have a positive effect on overall energy consumption.

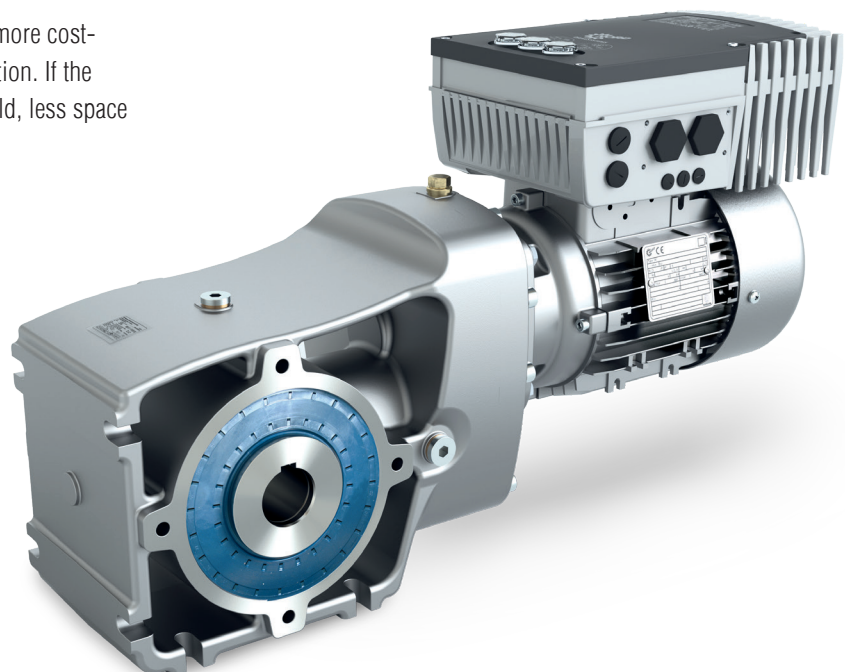

# Decentralized drive technology: Greater flexibility, lower costs

## Quick commissioning, simple maintenance

With decentralized solutions, spatial proximity of the motor and inverter reduce the wiring effort and cabling between the cabinet and drive in the field to a minimum. Only short cables are required, if needed at all, and do not require shielding due to their optimal EMC properties. Since the frequency inverters are installed directly on the motor or in its immediate vicinity, commissioning close to the motor is also possible, which can reduce walking distances and improve safety. Decentralized solutions are extremely maintenance and service-friendly. Defective units can be repaired or replaced quickly and easily. Factory pre-configuration of the frequency inverters also adds to the ease of commissioning.

## High level of flexibility

The decentralization of drive technology enables a system design that consists of autonomous production islands that largely regulate their own processes. This reduces load on the higher level control system and decreases system complexity. Because of this, the entire system is easier to maintain and works more efficiently, and the modular structure provides maximum flexibility, as changes and extensions can be made easily at any time.

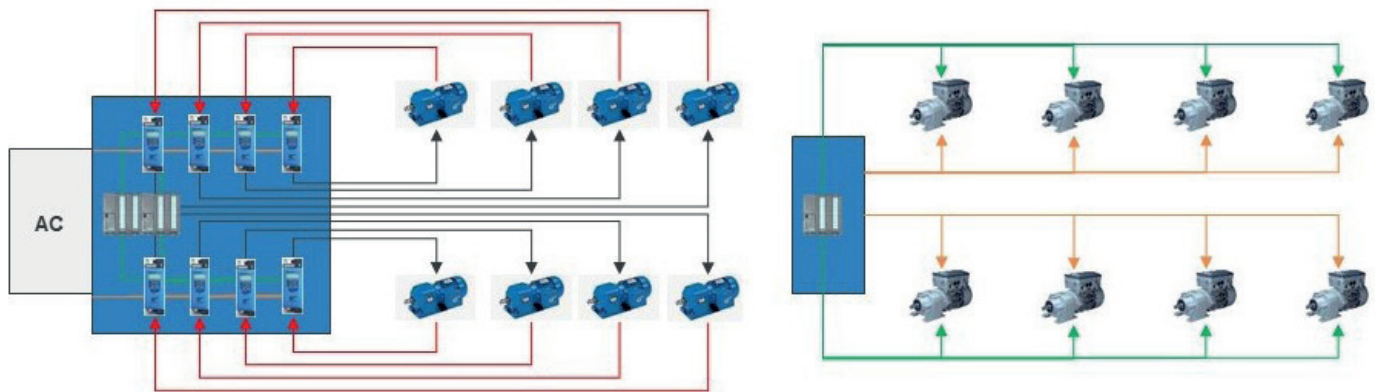

Centralized and decentralized technology for large numbers of drives

Source: *NORD DRIVESYSTEMS*

# Success story: Palletizing machines

---



Palletizing machine with decentrally controlled asynchronous drive systems

Source: Symach

## Switching from servo to decentralized drive technology

A practical example of the palletizing machines of a Dutch machine manufacturer shows how the changeover from drives with centrally controlled servo technology to decentrally controlled drive technology can be successful. Palletizing machines play a key role in the production and distribution process and they must function smoothly so that product flows do not come to a standstill. They must also be flexible enough to adapt to various goods and applications.

In the past, the company relied entirely on centralized drive systems. This required control boxes to be installed on the top of the machine, which took up a lot of space, increased costs, and obstructed access during maintenance work. In the course of modernization, the centralized servo technology was replaced by decentralized drive technology with asynchronous motors. This resulted in the Total Cost of Ownership being reduced significantly.

# Success story: Palletizing machines

---

## Precise and dynamic palletizing machines

These palletizing machines place each product individually. A specially designed gantry enables precise, gentle handling. The three to four meter high machines are fed via a conveyor belt and the goods are picked up by a gripper. Bags slide against a fixed stop and are aligned by a centering unit so that the gripper can drop them exactly at the programmed position. This enables precise, stable overlap stacking with the ability to easily program different stacking patterns. The pallet deck is lowered layer by layer during the stacking process until a defined final height is reached. The fully loaded pallet is then transported via a roller conveyor to a wrapping machine and wrapped with film.

## Reduced Total Cost of Ownership

Decentralized asynchronous drive systems have proven their worth in controlling the complex motion sequences of the palletizing machine's gripper. Centering of the unit is significantly more economical than the previous servo technology solution.

The new configuration also provides the necessary dynamic performance, opens up new design possibilities for developers, and resulted in cost savings in various areas.

Advantages of the new system are not only lower procurement costs, but also greater choice for machine designers, as asynchronous motors are available everywhere in a wide range, are easy to maintain, and can be easily combined with different types of gear units and frequency inverters. Additionally, they are very easy to replace, particularly with the push-on version that utilizes plug-in connectors. The elimination of the control cabinet on these palletizing machines also results in lower installation costs. The wiring of sensors and actuators in the machine is carried out with pre-assembled plugs with reduced cable lengths, zero errors, and the shortest possible installation time. M23 plug connectors that are expensive and time consuming to assemble and install have become obsolete; conventional installation work such as stripping, setting ferrules, and clamping are no longer necessary. If you combine all advantages and disadvantages, the palletizing machines with decentralized asynchronous drive technology result in a lower Total Cost of Ownership.

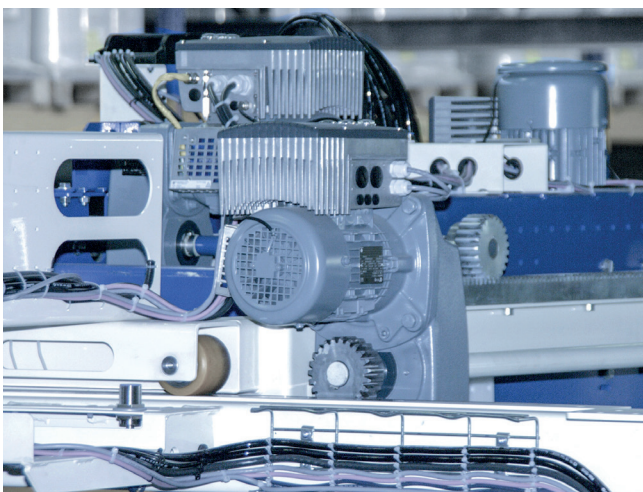

The frequency inverter is placed directly on the motor  
Source: Symach

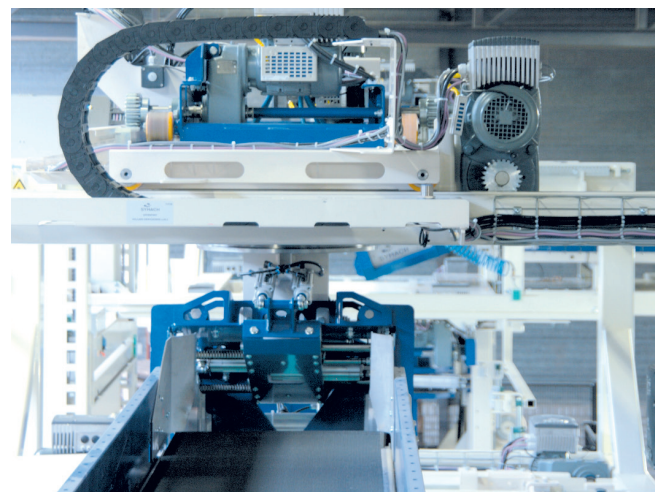

Precise and dynamic performance  
Source: Symach

# Summary: Optimum performance, maximum economic efficiency



## Advantages of decentrally controlled drive technology with frequency inverters in end-of-line packaging:

- ▶ Cost benefits of up to 50%
- ▶ More cost-effective, short-term service and repair options
- ▶ Constructive freedom in machine design
- ▶ High level of flexibility
- ▶ Reduced machine footprint
- ▶ Modularity: highly configured, flexible drive solutions for specialized applications

In summary, the following can be said: asynchronous motors with decentralized frequency inverters and encoder feedback via absolute or incremental encoders enable highly economic and precise positioning applications, as well as dynamic movement of large, heavy packaging units. This makes the technology a real solution for application fields such as end-of-line packaging, where heavy loads and high forces are the norm. When used with decentralized frequency inverters, components such as control cabinets and wiring are also eliminated and the setup effort is significantly lower. Furthermore, space saving is an important advantage of this decentralized approach. All in all, significant cost savings of up to 50% are possible.

Decentralized drive solutions with controlled frequency inverters offer great advantages in end-of-line packaging.

Source: *NORD DRIVESYSTEMS, istock.com/1933bkk*

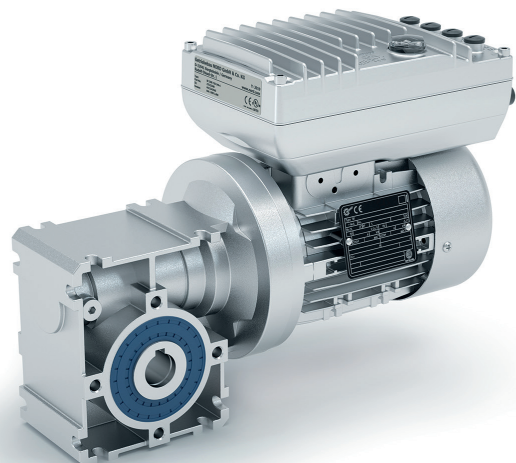

# NORD drive solutions for end-of-line packaging

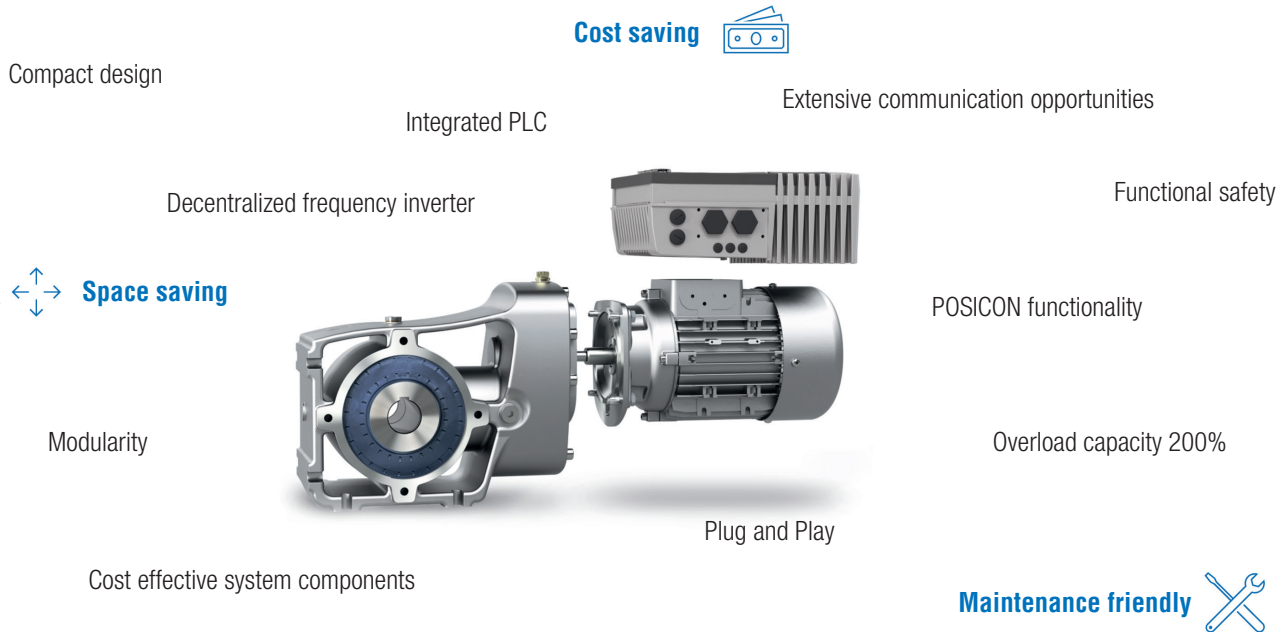

The drive concepts from NORD DRIVESYSTEMS make an important contribution to TCO reduction

Source: NORD DRIVESYSTEMS

As one of the world's leading complete suppliers of electrical, mechanical, and electronic drive technology, NORD DRIVESYSTEMS is a strong, reliable partner for the packaging industry. For end-of-line packaging, the company implements modular drive concepts that are precisely configured to specific application and customer requirements. The modular system, special expertise, extensive industry knowledge, the wide range of standardized components and customer-specific solutions from NORD are essential factors of success for economic and efficient drive solutions – contributing to the reduction of Total Cost of Ownership (TCO). NORD DRIVESYSTEMS also offers powerful solutions in the adjacent areas of intralogistics conveyor and process technology, such as those within the food and beverage industry.

## Your advantages with NORD decentralized drive solutions:

- ▶ Significant cost savings
- ▶ Compact system design
- ▶ Reduced maintenance effort through plug-and-play technology
- ▶ Integrated PLC for drive-related functions
- ▶ Energy-saving function for partial load range
- ▶ Integrated POSICON functionality
- ▶ High overload capacity of 200 – 300%
- ▶ Functional safety with STO and SS1
- ▶ Modular system
- ▶ Highest process reliability
- ▶ Variety of mechanical (flanges, shaft sizes) and electronic bus interfaces
- ▶ Value-added engineering
- ▶ Global services

In case of any questions about the NORD product portfolio,  
please contact:

**Getriebbau NORD GmbH & Co. KG**

Getriebbau-Nord-Str. 1

22941 Bargteheide

Tel.: +49 4532 289-0

Fax +49 4532 289-2253

[nordacpro@nord.com](mailto:nordacpro@nord.com)