

**Aluminium  
drive technology**  
Lightweight and corrosion resistant

**NORD<sup>®</sup>**  
**DRIVESYSTEMS**  
Our Solution. Your Success.

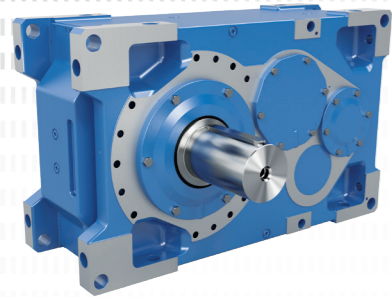

Industrial gear units

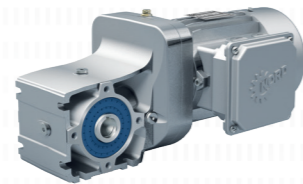

Geared motors



Frequency inverters and motor starters



- ▶ Headquarters and technology centre in Bargteheide near Hamburg.
- ▶ Innovative drive solutions for more than 100 branches of industry.
- ▶ 7 production locations with cutting edge technology produce gear units, motors and drive electronics for complete drive systems from a single source.
- ▶ NORD has 48 subsidiaries in 36 countries and further sales partners in more than 50 countries, providing local stocks, assembly centres, technical support and customer service.
- ▶ More than 4,900 employees throughout the world create customised solutions.



Headquarters in Bargteheide



Gear unit production



Inverter production



Motor production



Production and assembly



Motor mounting

# Aluminium drive technology



## Aluminium UNICASE housing

NORD DRIVESYSTEMS uses a high-strength aluminium alloy for its aluminium series of gear units, motors and inverters. The lightweight yet highly durable UNICASE housings are manufactured in a single step using the latest production methods.

## Advantages

- ▶ Low weight – As a light metal, aluminium has a density around three times smaller than steel.
- ▶ High cooling capacity – Aluminium's thermal conductivity is eight times higher than that of stainless steel.
- ▶ High level of corrosion protection – Aluminium forms a protective oxide layer.

## NORDBLOC.1® 1-stage helical gear units

The single-stage NORDBLOC.1® helical gear units, with its Smooth surface, is an innovative drive solution for all applications where cleanliness is essential. These advanced and patented gear units do not have installation openings. This increases the stability of the product and at the same time provides a smoother surface on which neither solidified liquids or solid materials can accumulate.

## Advantages

- ▶ Quiet running
- ▶ High axial and radial load capacities enable reliable operation
- ▶ Application-specific versions
- ▶ Easy to clean
- ▶ High-efficiency for low operating costs
- ▶ Innovative design

## Features

- ▶ Smooth surfaces
- ▶ No installation openings
- ▶ No sealing caps

## NORDBLOC.1® 1-stage helical gear units (Catalogue G1000)

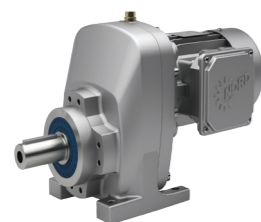

- ✓ Foot or flange mounted
- ✓ Die-cast aluminium housing
- ✓ UNICASE housing
- ✓ For high speed applications

Sizes: 5  
 Power: 0.12 – 7.5 kW  
 Torque: 25 – 311 Nm  
 Speed ratio: 1.07 – 14.00:1

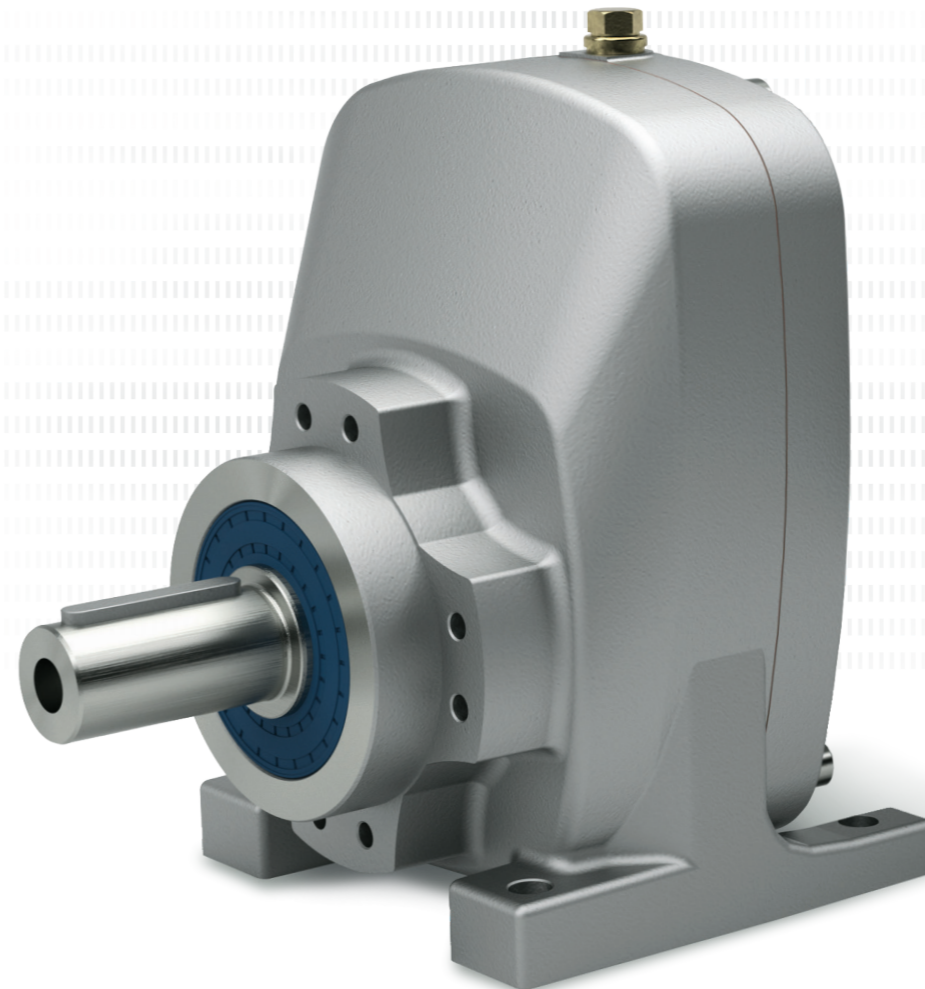

## Universal mounting

- ▶ Foot mounted version
- ▶ B5 flange version
- ▶ B14 front flange version
- ▶ Foot mounted version with B5 or B14 flange

## Miscellaneous drive components

- ▶ Integral motor (geared motor)
- ▶ NEMA C flange motor adapter
- ▶ IEC, B5 and B14 motor adapter
- ▶ Free drive shaft
- ▶ Smooth motors

## Wash-down design

The single-stage helical gear unit series in combination with the NORD smooth surface motors is especially suited for applications where cleanliness is essential.

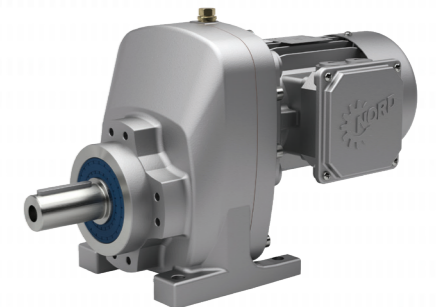

Foot mounted housing, B14 flange, integrated motor

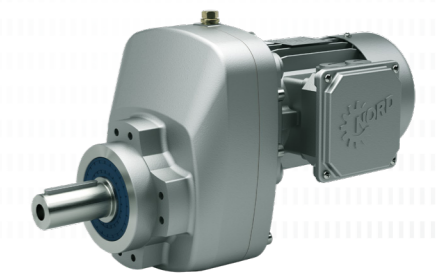

Housing with B14 flange, integrated motor

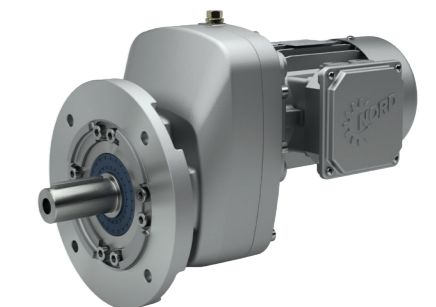

Housing with B5 flange, integrated motor

## NORDBLOC.1® 2-stage helical gear units

One of the objectives during the development of the new NORDBLOC.1® gear units was to create a Smooth surface on which neither liquids nor solids could be deposited. This is an advantage in applications where cleanliness is important. These innovative and patented gear units do not have any installation openings. This increases the strength of the product and also provides a smoother surface.

### Advantages

- ▶ Less operating noise
- ▶ High output torque
- ▶ Outstanding reliability, low maintenance
- ▶ Easy to clean

### Features

- ▶ Smooth surfaces
- ▶ No installation openings
- ▶ No sealing caps

## NORDBLOC.1® 2-stage helical gear units (Catalogue G1000)

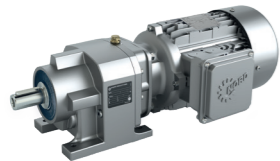

- ✓ Foot or flange mounted
- ✓ Die-cast aluminium housing
- ✓ UNICASE housing
- ✓ Industry standard dimensions

Sizes: 5\*  
 Power: 0.12 – 7.5 kW  
 Torque: 55 – 640 Nm  
 Speed ratio: 2.10 – 402.80:1

\* More sizes with UNICASE grey cast iron housing are available.

### NORD UNICASE housings

NORD UNICASE housings are precisely machined to meticulous standards. Internal reinforcements further increase strength and rigidity. All bearings and seal seats are contained within the die casting, eliminating joints which can weaken the housing and allow oil leakage. Holes and attachment surfaces are machined in one operation. This enables close tolerances and increased service life for all components.

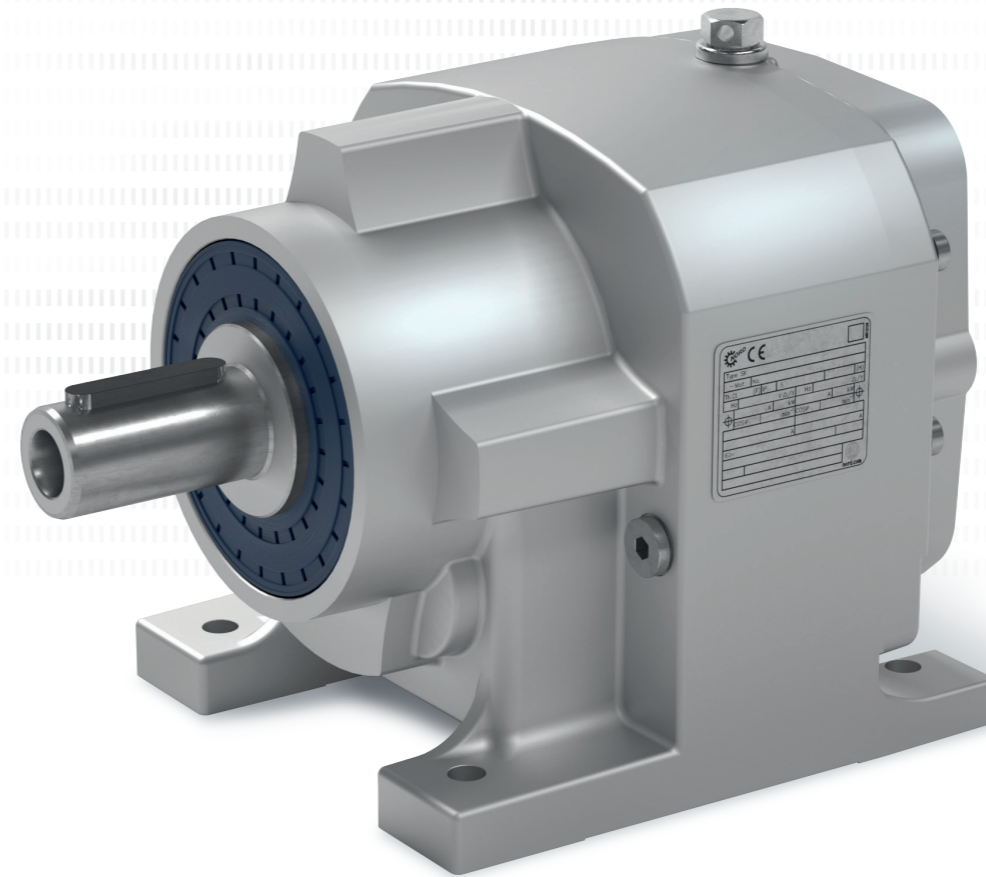
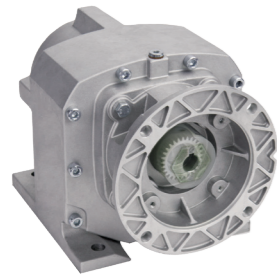

### Universal mounting

- ▶ Foot mounted version
- ▶ B5 flange version
- ▶ B14 front flange version
- ▶ Foot mounted version with B5 or B14 flange

### Miscellaneous drive components

- ▶ Integral motor (geared motor)
- ▶ NEMA C flange motor adapter
- ▶ IEC, B5 and B14 motor adapter
- ▶ Free drive shaft
- ▶ Smooth motors

### Wash-down design

The 2-stage helical gear unit series in combination with the NORD smooth surface motors is especially suited for applications where cleanliness is essential.

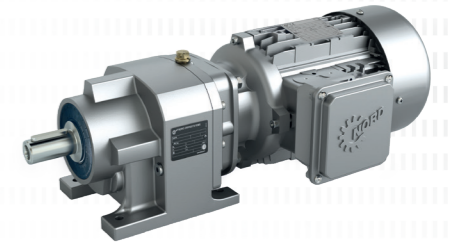

### NORDBLOC.1® 2-stage bevel gear unit

- ▶ Compact, spacesaving design
- ▶ Simple mounting
- ▶ Motor coupling
- ▶ Low bearing stress (long bearing life)
- ▶ Lightweight
- ▶ Large output bearings – the output bearing of the NORDBLOC.1® gear units has considerably larger dimensions than conventional designs. This is made possible by the innovative design, the so-called „staggered bearing configuration“.

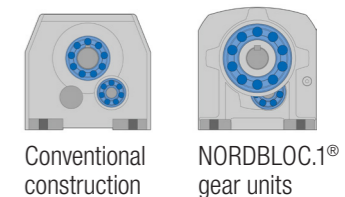

- ▶ Above-average radial forces possible
- ▶ Higher axial forces possible
- ▶ Longer bearing life

# Aluminium drive technology

## NORDBLOC.1® 2-stage bevel gear units

The new, performance-optimised 2-stage bevel gear units are an innovative NORD design made from high-strength aluminium alloy. Thanks to the wash-down version they are especially suitable for applications in the food industry. Other fields of use are for example conveyor belts, lifting gear and warehouse systems.

### Advantages

- ▶ The gear units have no recesses, cavities or undercuts. This ensures easy cleaning and drain-off of dirt and liquids.
- ▶ In combination with a smooth motor these gear units are ideal for use in the food industry.
- ▶ The wide range of speed ratios ( $i = 3.03$  up to  $70:1$ ) enables optimum adaptation to the customer's requirements.
- ▶ Greater safety through optional double seal

### Features

- ▶ Corrosion-resistant aluminium
- ▶ Easy to clean thanks to smooth surfaces (wash-down = liquids always drain off)
- ▶ Approx. 60% greater power density than the previous model
- ▶ Suitable for large forces due to enlarged, high-strength output shaft bearings
- ▶ Sealing options (such as double radial shaft sealing rings) provide high sealing reliability for special fields of application.
- ▶ Environmentally friendly due to minimised lubricant volume
- ▶ Flexible use due to compact design with short IEC adapter, integrated into the proven NORD modular system

## NORDBLOC.1® 2-stage bevel gear units (Catalogue G1014)

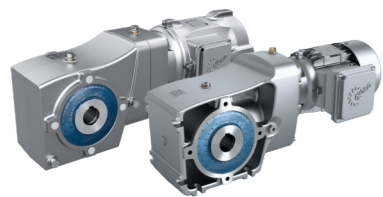

- ✓ Foot, flange or face mounted housing
- ✓ Aluminium housing
- ✓ Hollow or solid shaft

Sizes: 6  
 Power: 0.12 – 9.2 kW  
 Torque: 50 – 660 Nm  
 Speed ratio: 3.03 – 70:1

Developed and constructed according to the following standards:  
 EHEDG, ANSI/BISSC, ANSI/NSF

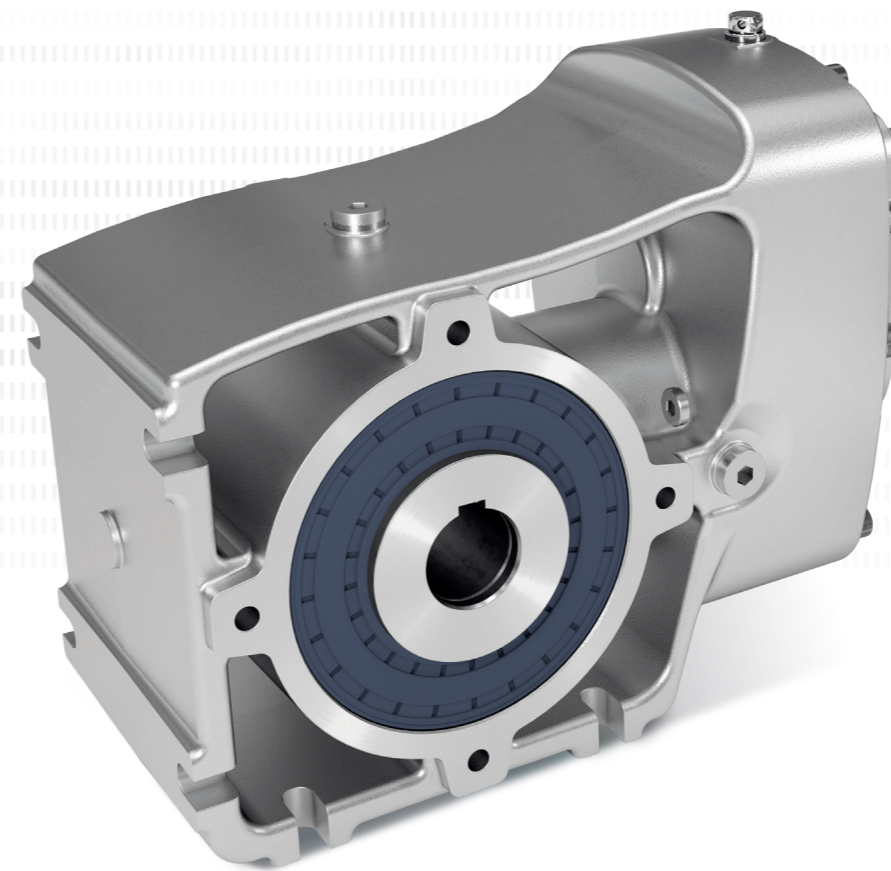

### Unique housing

- ▶ High-strength, with light weight
- ▶ Less use of materials
- ▶ Cool surfaces

### Specially suitable for the following areas

- ▶ Conveyor belts
- ▶ Lifting gear
- ▶ Warehouse systems

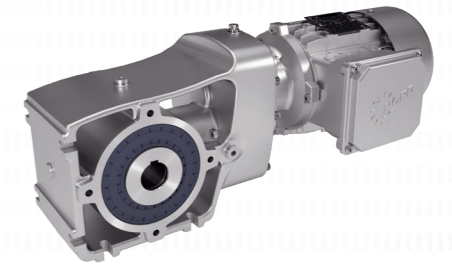

NORDBLOC.1® 2-stage bevel gear unit  
(Series SK92x72.1)

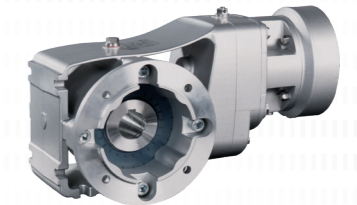

NORDBLOC.1® 2-stage bevel gear unit  
with IEC cylinder and flange  
(Series SK92x72.1)

# Aluminium drive technology

## NORDBLOC.1® parallel shaft gear units

In combination with central or decentralised frequency inverters, parallel shaft geared motors provide ultimate efficiency and economy for a wide range of system solutions. The UNICASE concept guarantees long life cycles and low maintenance.

### Advantages

- ▶ Slim design for space-saving installation
- ▶ Various bearing concepts guarantee high axial and radial load capacities
- ▶ Outstanding reliability, low maintenance
- ▶ Quiet running
- ▶ Robust design for long life and easy maintenance
- ▶ Inexpensive to run thanks to low maintenance
- ▶ High-efficiency for low operating costs
- ▶ Optional: Drywell version for mixers and agitators

### Features

- ▶ Smooth surfaces
- ▶ No installation openings
- ▶ No sealing caps

## NORDBLOC.1® parallel shaft gear units (Catalogue G1000)

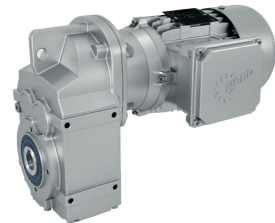

- ✓ Food, flange or face mounted housing
- ✓ Compact design
- ✓ Hollow or solid shaft
- ✓ Low maintenance

Sizes: 4\*  
 Power: 0.12 – 4.0 kW  
 Torque: 130 – 400 Nm  
 Speed ratio: 4.03 – 356.89:1

\* More sizes with UNICASE grey cast iron housing are available.

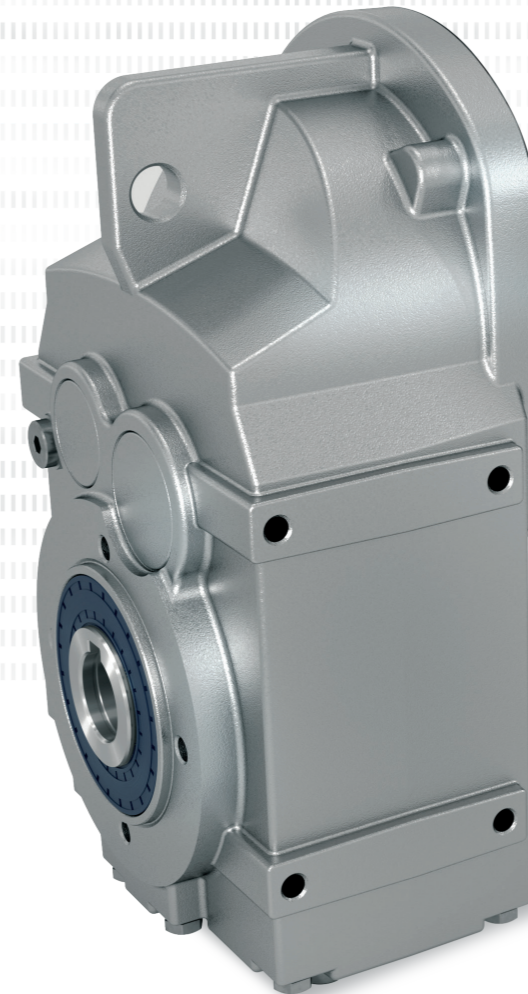

### Universal mounting

- ▶ Foot mounted version
- ▶ B5 flange version
- ▶ B14 front flange version
- ▶ Foot mounted version with B5 or B14 flange

### Miscellaneous drive components

- ▶ Integral motor (geared motor)
- ▶ NEMA C flange motor adapter
- ▶ IEC, B5 and B14 motor adapter
- ▶ Free drive shaft
- ▶ Smooth motors

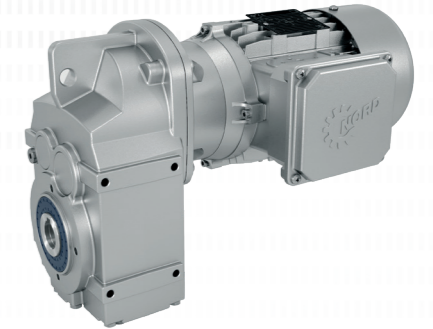

NORDBLOC.1® parallel shaft gear unit SK 0182

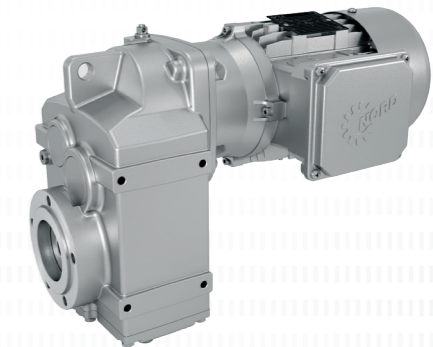

NORDBLOC.1® parallel shaft gear unit SK 0282

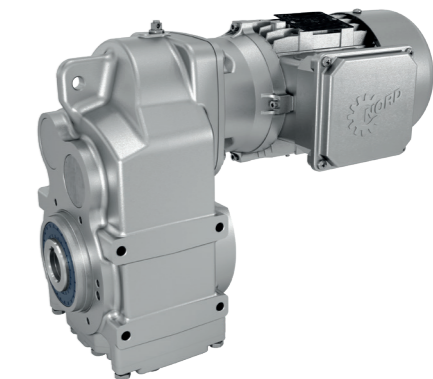

NORDBLOC.1® parallel shaft gear unit SK 1282

# Aluminium drive technology

## UNIVERSAL SI and SMI worm gear units

NORD worm gear units provide a high power density and are extremely compact. They feature low-noise torque transmission. Due to the simple design they provide considerable installation space advantages in comparison with other types of gear unit. The gear units are available as SI and SMI versions.

### Advantages

- ▶ Due to the large range of possible shaft diameters the gear units offer greater flexibility for customers.
- ▶ IEC adapters for all sizes offer several standard motor mounting options
- ▶ Operation as a double gear unit for very high speed ratios is possible
- ▶ The improved surface structure of SMI worm gear units with lesser roughness due to chill-casting gives dirt less opportunity to accumulate (wash-down design)
- ▶ Due to the large selection of components from the modular system, the gear units can be optimally adapted to particular requirements
- ▶ W-cylinder (free drive shaft)
- ▶ H10 first stage for larger speed ratios
- ▶ Torque support

### Features

- ▶ SMI gear units made from chill-cast aluminium with smooth surfaces especially suit applications in the food and beverage industry
- ▶ Gears and shafts from the tried-and-tested modular system
- ▶ SMI gear units are available for torques from 21 up to 427 Nm

## UNIVERSAL SI and SMI worm gear units (Catalogue G1035)

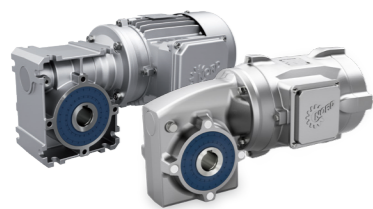

- ✓ Modular
- ✓ Life-long lubrication
- ✓ Universal attachment
- ✓ IEC version

Sizes: 5  
 Power: 0.12 – 4.0 kW  
 Torque: 21 – 427 Nm  
 Speed ratio: 5.00 – 3,000:1

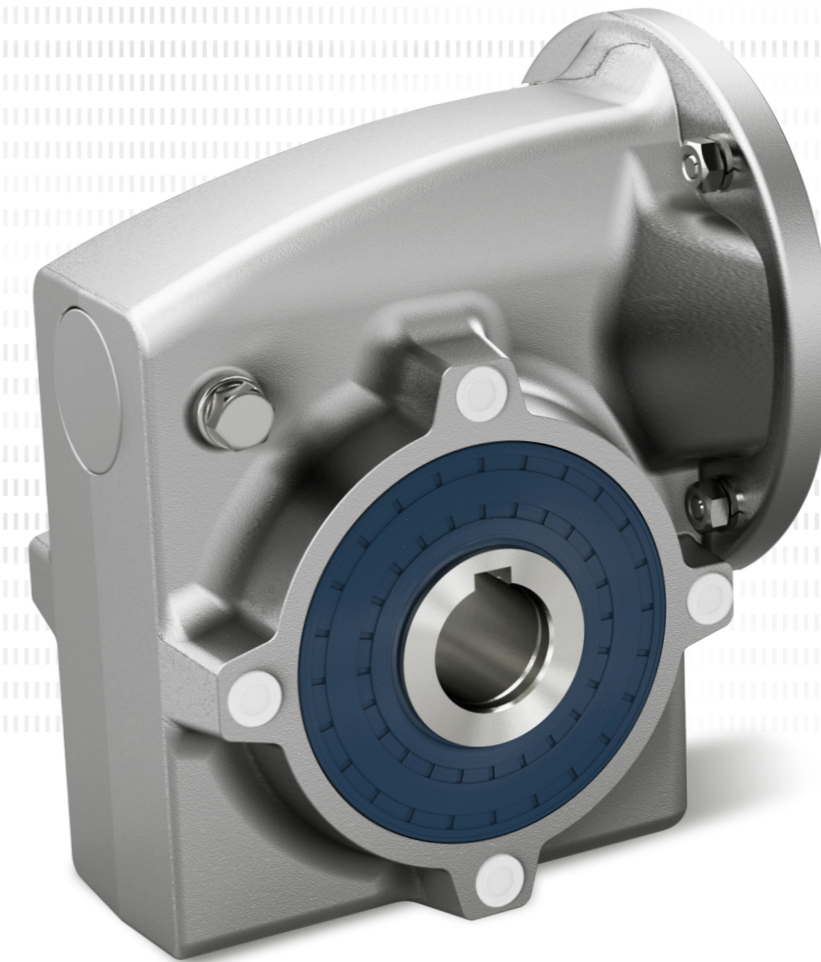

### Versatile application

- ▶ Lightweight housing
- ▶ Large selection of shaft diameters
- ▶ SMI up to size 5

### Modular and flexible

- ▶ Use of various motors with IEC adapters
- ▶ The SMI flange housing can be combined with all SI series flanges
- ▶ Optimised NORD gear unit modules
- ▶ Standard IEC B5/B14 interfaces for all sizes of gear units

## DuoDrive – integrated geared motor concept

DuoDrive is a revolutionary integrated gear unit/motor concept in a hygienic wash-down design. It combines the high-efficiency IE5+ motor and a single-stage helical gear unit in one housing. Thanks to its optimised system efficiency, high power density and very low noise emissions, it is especially suitable for use in the fields of intralogistics, food and pharmaceutical industries. Together with its simple plug-and-play commissioning, the complete DuoDrive solution results in a significant reduction in Total Cost of Ownership (TCO) compared to other drive systems.

### Advantages

- ▶ High system efficiency of up to 92 %
- ▶ Reduced total costs of ownership (TCO) and faster Return on Investment (ROI)
- ▶ Reduced number of versions through constant motor torque over a wide speed range
- ▶ Compact wash-down design for optimal installation space utilisation
- ▶ Market-compatible connection dimensions for simple replacement
- ▶ Motor can be operated worldwide

### Features

- ▶ Compact installation volume and thus space-saving
- ▶ High power density
- ▶ Quiet running through very low noise emissions
- ▶ Fewer wearing parts result in less maintenance

## DuoDrive – integrated geared motor concept (Catalogue G5010)

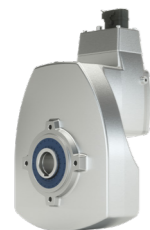

- ✓ High-efficiency IE5+ motor
- ✓ Simple plug-and-play commissioning
- ✓ High system efficiency
- ✓ IP69K optional

Sizes: 1  
 Power: 0.35 – 3 kW  
 Torque: 26 – 80 Nm  
 Speed ratio: 3.24 – 16.2:1

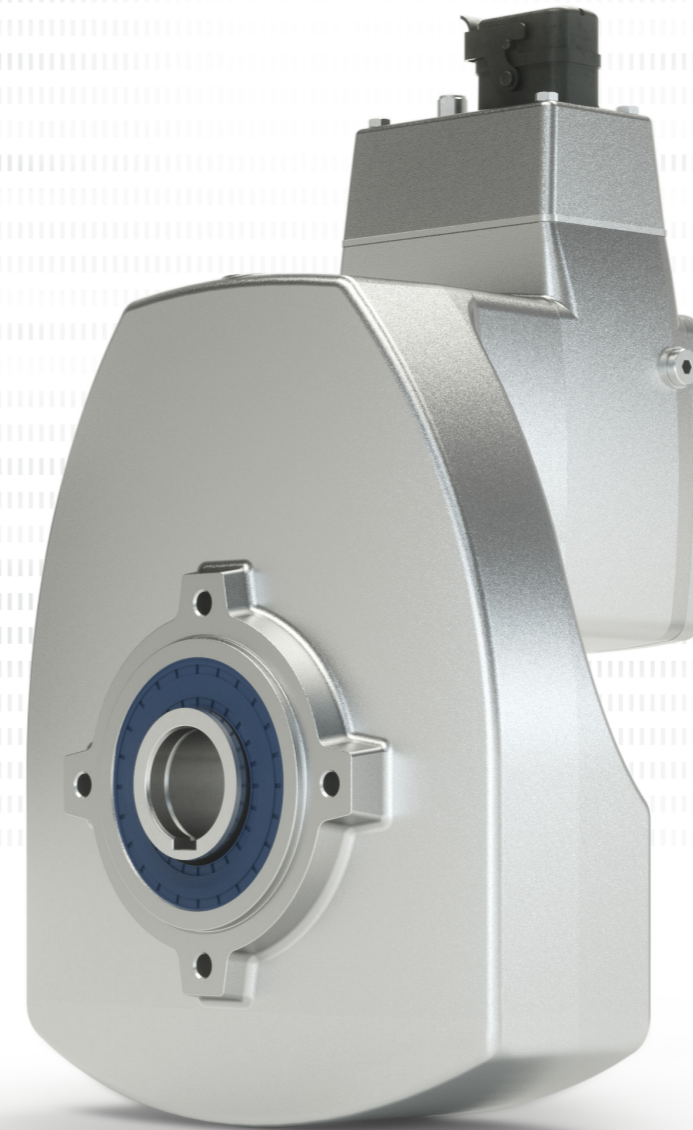

### Simple mounting

- ▶ Plug-and-play solution for fast commissioning
- ▶ Variety of motor connection options
- ▶ Flexible attachment options: B5 or B14 flange

### Perfect system solution

- ▶ Integral motor (geared motor)
- ▶ Various motor options such as holding brake or integrated encoder system
- ▶ Torque arm, shrink disc and GRIPMAXX™

### Wash-down design

The DuoDrive series is especially suited for applications where cleanliness is essential.

### Reduction of variants

By way of a targeted reduction of versions, it is possible to minimise administrative expenses and to set up leaner manufacturing, logistics, storage and service processes.

The new generation of IE5+ motors combines the advantages of the modular system with the possibilities of reducing variants. The solution will be tailored to each customer and features the following advantages:

- ▶ Worldwide usable permanent magnet synchronous motor (PMSM) of the latest generation in a single helical in-line gear unit housing
- ▶ Utilisation of the high system overload capacity
- ▶ Large adjustment range
- ▶ Explicitly tailored to the individual load range
- ▶ Minimal space requirements paired with high power density



## Energy-efficient ribbed and smooth motors

NORD DRIVESYSTEMS builds energy-saving three-phase motors both with and without brakes for the international market. Our own motor production facilities guarantee that NORD DRIVESYSTEMS is independent from supply bottlenecks and can ensure short delivery times. This is a decisive benefit for our customers. The use of NORD energy-saving three-phase motors with considerably higher efficiencies allows you to reduce operating costs.

### Advantages

- ▶ Smooth surfaces, especially suitable for applications in the food and beverage industry
- ▶ IE3/IE5+ motors have a greater efficiency than the previous EFF2 motors.
- ▶ IE3/IE5+ motors produce less waste heat.
- ▶ IE3/IE5+ motors have a longer service life than previously common motors.
- ▶ IE3/IE5+ motors contribute to reducing operating costs.

### Features

- ▶ Die cast aluminium (smooth motors)
- ▶ IE3/IE5+ motors from NORD have an „extended operating range“, which means that no safety reserves, or lower safety reserves need to be taken into account for the design of the drive unit.

### Motors (Catalogue M7000)

- IE3** ▶ IE3 asynchronous motors
- IE5+** ▶ IE5+ synchronous motors (Overload capacity up to 300% with encoder)

### International energy efficiency standards

- ▶ EU: IE1 – IE4 as per IEC 60034-30
- ▶ US: ee labeling as per EISA 2014 (Dept. of Energy)
- ▶ CA: CSA energy verified as per EER 2010
- ▶ CN: CEL as per GB 18613
- ▶ KR: KEL as per REELS 2010
- ▶ BR: Alto Rendimento as per Decreto nº 4.508
- ▶ AU: MEPS as per AS/NZS 1359.5

NORD DRIVESYSTEMS develops its own motors and supplies them to all major markets throughout the world. Our own developments ensure a high level of independence from external suppliers and therefore provides our customers with the decisive advantage of short and highly dependable delivery times.

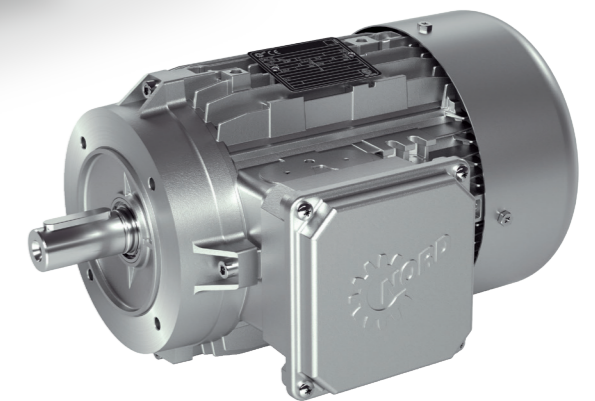
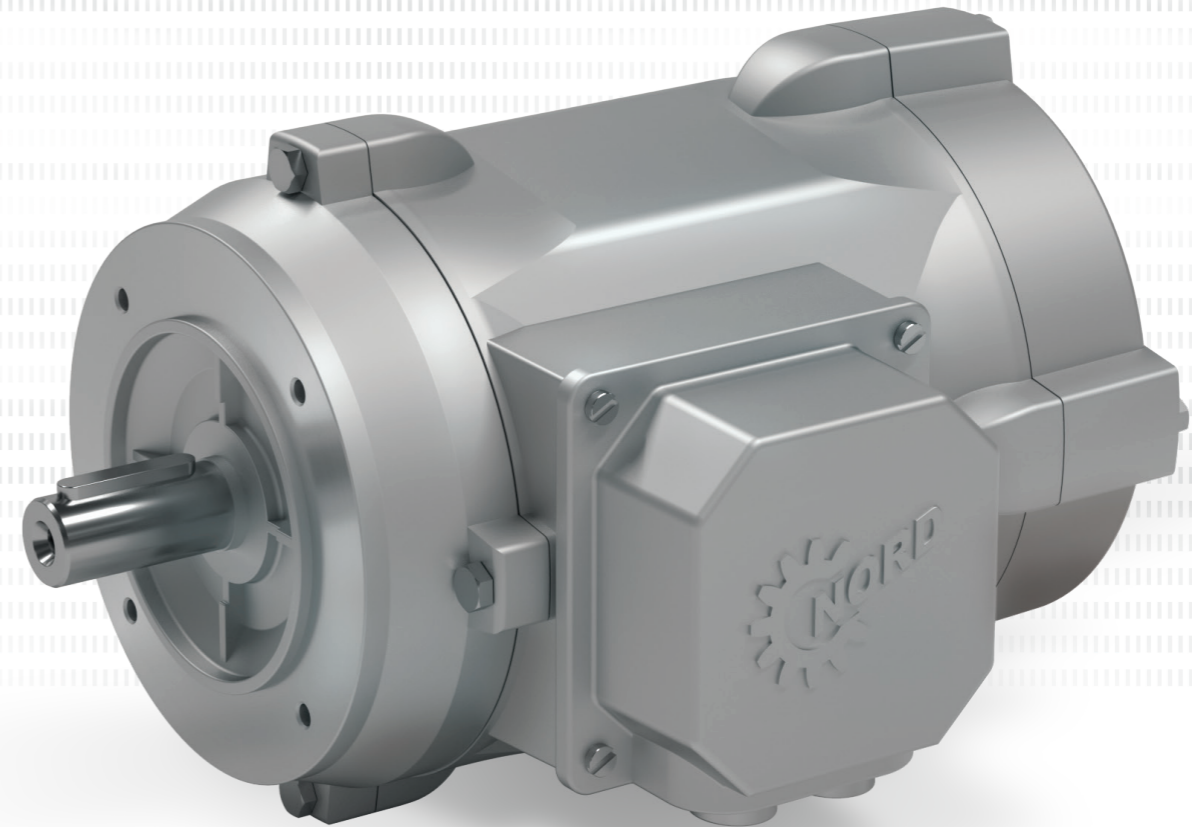

IE3 asynchronous standard motor

### IE3/IE5+ motors

- ▶ High-efficiency
- ▶ Wide voltage range
- ▶ Lower heat losses
- ▶ High power reserves
- ▶ Long service life
- ▶ Worldwide approvals

# Aluminium drive technology

## Decentralised frequency inverters and motor starters

Our decentralised inverters can be freely configured, to adapt them to any application. Because of this, you obtain an optimum solution and at the same time reduce your installation and operating costs. Frequency inverters from NORD already comply with the regulations of energy efficiency class IE2 of the new Ecodesign regulation (EU) 2019/1781 (valid from 1 July 2021).

### Advantages

- ▶ Efficient drive technology significantly reduces the costs of the plant design
- ▶ Freely configurable or optionally expandable enabling versatile application
- ▶ Can be integrated into all automation architectures through connection to common bus systems and Industrial Ethernet
- ▶ Simple installation and maintenance thanks to simple plug-in connections

### Features

- ▶ High precision regulation with current vector control
- ▶ Compatible with all common bus systems
- ▶ PLC functionality for drive-related functions
- ▶ Energy-saving function for partial load operation
- ▶ Integrated line filters for compliance with EMC regulations
- ▶ Operation of synchronous and asynchronous motors
- ▶ Scalable functions

## NORDAC ON/ON+ SK 300P frequency inverters (Flyer S9013 and F3080)

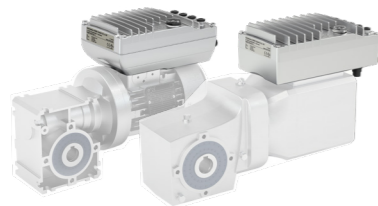

- ✓ Compact, space-saving design
- ✓ Programmable logic controller (PLC)
- ✓ Parameterisation via plug-in control module, NORDCON software tool or app

Sizes: 2  
Voltage: 3 ~ 400V  
Power: 0.37 – 0.95 kW

## NORDAC BASE SK 180E frequency inverters (Catalogue E3000)

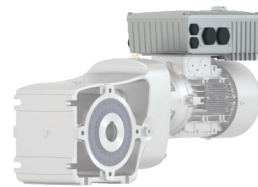

- ✓ Stand-alone operation
- ✓ 4 parameter sets
- ✓ Sensorless current vector control (ISD control)
- ✓ Integrated PLC

Sizes: 2  
Voltage: 1~ 110 – 120 V, 1 ~ 200 – 240 V, 3 ~ 200 – 240 V, 3 ~ 380 – 500 V  
Power: 0.25 – 2.2 kW

## NORDAC START SK 135E motor starters (Catalogue E3000)

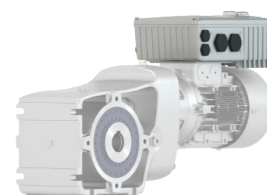

- ✓ Integrated electronic brake rectifier
- ✓ Consistent parameter structure
- ✓ Reversing starter with soft start function

Sizes: 2  
Voltage: 3~ 200 – 240 V, 3~ 380 – 500 V  
Power: 0.12 – 3 kW resp. up to 7.5 kW

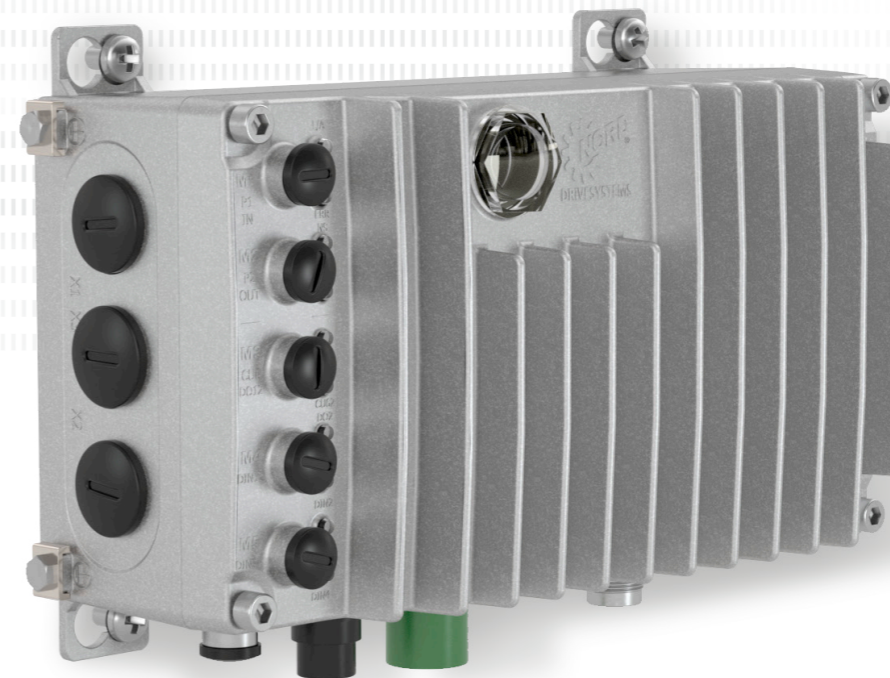

### Future-proof platform

- ▶ IIoT capable
- ▶ Plug-and-play
- ▶ Standardised
- ▶ Wide frequency range
- ▶ Integrated Industrial Ethernet Interfaces



NORDAC ON+ SK 300P  
(optimised for IE5+ motor)

### Wash-down design

The NORD inverters and motor starters SK 300P, SK 180E and SK 135E in combination with Smooth surface motors and gear units are especially suited for application in hygiene areas.



NORDAC ON SK 300P



NORDAC BASE SK 180E



NORDAC START SK 135E

**EN**

Headquarters:  
Getriebbau NORD GmbH & Co. KG  
Getriebbau-Nord-Str. 1  
22941 Bargteheide, Germany  
T: +49 45 32 / 289 0  
F: +49 45 32 / 289 22 53  
info@nord.com