

SK TU4-ETH-M12

Part number: 275 281 233

Industrial Ethernet – External bus interface

The bus interface may only be installed and commissioned by qualified electricians. An electrician is a person who, because of their technical training and experience, has sufficient knowledge with regard to

- Switching on, switching off, isolating, earthing and marking power circuits and devices,
- Proper maintenance and use of protective devices in accordance with defined safety standards.

⚠ DANGER

Danger of electric shock

The frequency inverter carries hazardous voltage for up to 5 minutes after being switched off.

- Work must not be carried out unless the frequency inverter has been disconnected from the voltage and at least 5 minutes has elapsed since the mains was switched off.

Validity of document

This document is only valid in conjunction with the operating instructions of the respective frequency inverter and the bus communication manual for this bus interface (📖 See overview at end of document). These documents contain all of the information that is required for safe commissioning of the bus interface module and the frequency inverter.

Scope of delivery

1 x	Bus interface	SK TU4-ETH-M12
4 x	Hexagonal socket screw	M4 x 40 mm
Required accessories:		
1 x	Bus connection unit TI 275280000	SK TI4-TU-BUS (Part no.: 275 280 000)



Field of use

External technology unit for connecting a decentralised frequency inverter (NORDAC *BASE*, NORDAC *FLEX*) to the **Industrial Ethernet** (EtherCAT, PROFINET IO and EtherNet/IP). The bus interface can be mounted directly on or in the immediate vicinity of the frequency inverter. It is connected with the frequency inverter via the system bus and can directly control up to four frequency inverters. Eight digital inputs and two digital outputs are available.

Technical Information / Datasheet		SK TU4-ETH-M12			
Industrial Ethernet Module	TI 275281233	V 1.3	4123	en	

Technical data
Bus interface

Temperature range	-25°C ... +50°C
Temperature class	Class 3k3
Supply voltage	24 V ± 20%, ≈ 100 mA Polarity protected

Vibration resistance	3M7
Protection class	IP55
Dimensions [mm]*	H x W x D: 95 x 136 x 99

* Bus interface fitted to bus connection unit
Depth: 108 mm with cover caps on M12 connection

Digital input – Operating range	Low: 0 V ... 5 V, High: 15 V ... 30 V
Digital input – Specific data	R _i = 10 kΩ, Input capacitance: 10 nF, Response time 1 ms, Inputs as per EN 61131-2 type 1

Bus specification

EtherCAT	max. 100 Mbaud
EtherNet/IP PROFINET IO	electrical isolation 500 V _{eff}
Bus connection	2 x M12
Bus termination	carried out automatically
Status display	6 LED
Topology	star*, tree, ring, line

* additional switch required for "star" topology

Cable	min. Ethernet CAT-5
Max. cable length	100 m between two Ethernet participants
Shield	via M12 directly on PE
PE port	via PE screw terminal in connection box

Power

Parameter read access to frequency inverter	≈ 12 ms
Parameter write access with saving in EEPROM	≈ 25 ms

Features of the bus interface when using EtherCAT

Parameterisation	via CoE (CANopen over EtherCAT)
Error messages (emergency messages)	according to CiA 301
Identification (Hot-Connect)	Configured Station Alias (via bus interface parameter) or Explicit Device Identification (via DIP switch or bus interface parameter)
Distributed Clocks	are not supported
Access for NORD diagnosis tool	see section "Parameter access and diagnosis"
Firmware update	via File Access over EtherCAT (FoE)

Features of the bus interface when using EtherNet/IP

Implicit Messages (process data connections)	<ol style="list-style-type: none"> 1. Exclusive Owner Transport Class: Class 1 Trigger Mode: cyclic O → T [O (Originator/Master) → T (Target/Slave)] fixed/variable size supported Real time transfer format: 32-bit run/idle header Connection Type: Point2Point Priority: Scheduled T → O [T (Target/Slave) → O (Originator/Master)] fixed/variable size supported Real time transfer format: 32-bit run/idle header Connection Type: Multicast, Point2Point Priority: Scheduled 2. Listen Only Transport Class: Class 1 Trigger Mode: cyclic O → T [O (Originator/Master) → T (Target/Slave)] fixed size supported Real time transfer format: Heartbeat Connection Type: Point2Point Priority: Scheduled T → O [T (Target/Slave) → O (Originator/Master)] fixed/variable size supported Real time transfer format: 32-bit run/idle header Connection Type: Multicast Priority: Scheduled 3. Input Only Transport Class: Class 1 Trigger Mode: cyclic O → T [O (Originator/Master) → T (Target/Slave)] fixed size supported Real time transfer format: Heartbeat Connection Type: Point2Point Priority: Scheduled T → O [T (Target/Slave) → O (Originator/Master)] fixed/variable size supported Real time transfer format: 32-bit run/idle header Connection Type: Multicast, Point2Point Priority: Scheduled
Explicit Messages	yes
UCMM	is supported
DLR	is supported
Addressing	DIP switch (last byte of IP address), bus interface parameter, BOOTP (default) and DHCP possible
Access for NORD diagnosis tool	see section "Parameter access and diagnosis", or via Ethernet (TCP)
Firmware update	via NORDCON software (TCP)

Features of the bus interface when using PROFINET IO

Communication	<p>RT within an RT or within an IRT network</p> <p>Meaning of RT / IRT RT (Real Time) → Real-time communication for process data IRT (Isochronous Real Time) → Isochronous real-time communication for synchronised process data</p>
PROFINET IO addressing	automatic address allocation via IO controller with DCP (Discovery Configuration Protocol)
Data transfer	via Switched Ethernet
Auto negotiation	negotiation of transfer parameters
Auto crossover	transmission and reception cable may be crossed automatically in the switch
Conformance classes	CC-B and CC-C
Access for NORD diagnosis tool	see section "Parameter access and diagnosis", or via Ethernet (TCP)
Firmware update	via NORDCON software (TCP)

Installation

The bus interface must be attached to a suitable connection unit (SK TI4-TU...) and connected using the 4 provided M4 x 40 mm hexagon socket collar screws (Tightening torque 2 Nm). Installation details can be found in the data sheet for the relevant connection units.

Connections

The two Ethernet lines are connected exclusively via the two M12 sockets on the front. If the bus interface is the final subscriber on the line, one M12 socket can remain unoccupied. The use of EMC cable glands is recommended.

PIN	Signal	Description
1	TX+	Transmission Data +
2	RX+	Receive Data +
3	TX-	Transmission Data -
4	RX-	Receive Data -

PIN assignment
M12-4 socket
("D"- coded)

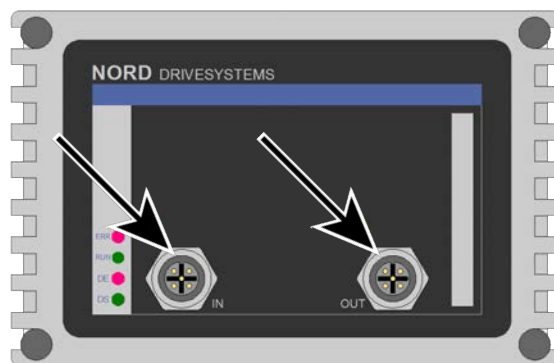

The connection to other signal and control lines takes place via the bus connection unit **SK TI4-TU-BUS(-C)**.

Terminals	Double-sprung terminal bar	2 x 18 contacts
Cable cross section	AWG 14-26	rigid: 0,14 ... 2,5 mm flexible: 0.14 ... 1.5 mm with wire end sleeves
PE connection	Via housing	
RJ12	RJ45 - socket	Interface for connecting a parameterisation tool

NOTICE

Short circuit possible

Attention must be paid to the fact that the GND connection (terminals 7 and 8) on the blue block is basically **not** short-circuit protected. In case of a short circuit between the 24 V connection (terminals 9 and 10) and the GND connection, the module may become defective.

- To remain short-circuit protected, the GND connection of the grey block must be used, even if the remaining connections are applied to the blue block.

Potential	Contact	Designation	Description	
1	Digital inputs	1	24 V	Supply potential (+24 V, ≤ 200 mA)
		2	24 V	Supply potential (+24 V, ≤ 200 mA)
		3	DIN5	Digital input 5
		4	DIN7	Digital input 7
		5	DIN6	Digital input 6
		6	DIN8	Digital input 8
		7	0 V	Reference potential (0 V / GND)
		8	0 V	Reference potential (0 V / GND)
		9	24 V	Supply potential (+24 V, ≤ 200 mA)
		10	24 V	Supply potential (+24 V, ≤ 200 mA)
2	System bus level and digital inputs	11	24 V	Supply voltage (+24 V)
		12	24 V	Supply voltage (+24 V)
		13	24 V	Supply voltage (+24 V)
		14	SYS +	System bus data line +
		15	0 V	Reference potential (0 V / GND)
		16	SYS -	System bus data line -
		17	0 V	Reference potential (0 V / GND)
		18	0 V	Reference potential (0 V / GND)
		19	DIN1	Digital input 1
		20	DIN3	Digital input 3
		21	0 V	Reference potential (0 V / GND)
		22	0 V	Reference potential (0 V / GND)
		23	24 V	Supply voltage (+24 V)
		24	24 V	Supply voltage (+24 V)
		25	DIN2	Digital input 2
		26	DIN4	Digital input 4
		27	0 V	Reference potential (0 V / GND)
		28	0 V	Reference potential (0 V / GND)
		29	24 V	Supply voltage (+24 V)
		30	24 V	Supply voltage (+24 V)
3	Digital outputs	31	VI 24V2	Supply potential (+24 V - in) of the digital outputs
		32	0V2	Reference potential (0 V / GND) of the digital outputs
		33	DOUT1	Digital output 1 (+24 V, ≤ 200 mA)
		34	DOUT2	Digital output 2 (+24 V, ≤ 200 mA)
		35	0V2	Reference potential (0 V / GND) of the digital outputs
		36	0V2	Reference potential (0 V / GND) of the digital outputs
4	Diagnosis	RJ12 - 1	RS485_A	Data cable RS485
		RJ12 - 2	RS485_B	Data cable RS485
		RJ12 - 3	GND	Reference potential (GND)
		RJ12 - 4	RS232_TxD	Data cable RS232
		RJ12 - 5	RS232_RxD	Data cable RS232
		RJ12 - 6	24 V	Supply voltage (+24 V)

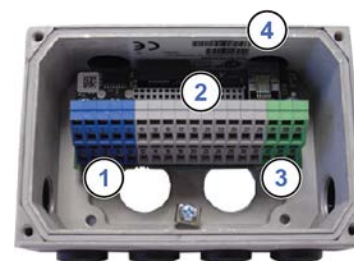

Connection example

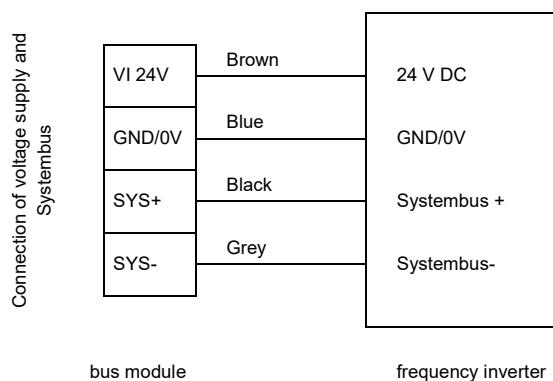

Configuration

Configuration of the bus interface is via DIP switches, but can also be performed via the parameter settings.

DIP switch positions are read after a “Power On” of the bus interface.

Configuration via DIP switch has priority over configuration via parameter settings.

Depending on the selected dialect, some DIP switches are without function. Details can be found below the following table.

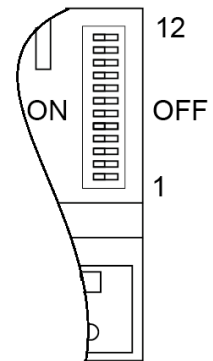

DIP switch factory setting: **OFF**

DIP switch											Meaning		
12	11	10	9	8	7	6	5	4	3	2	1	Address	
			0	0	0	0	0	0	0	0		0	
			0	0	0	0	0	0	0	1		1	
			0	0	0	0	0	0	1	0		2	
			
			1	1	1	1	1	1	1	1		255	
											0	Terminating resistor system bus (not set)	
											1	Terminating resistor system bus (set)	
		0										TCP rights (function see below)	
		1										TCP rights (function see below)	
0	0											Ethernet protocol (dialect) selection via parameter P899	
0	1											PROFINET IO	
1	0											EtherCAT	
1	1											EtherNet/IP	

Meaning of symbols	
0	DIP switch in “OFF” position
1	DIP switch in “ON” position

DIP 1	
Terminating resistor system bus	
PROFINET IO	The system bus must be terminated with a terminating resistor at its two physicals ends. If the bus interface is at the end of the system bus, the DIP 1 switch must be set to “ON”.
EtherCAT	
EtherNet/IP	

DIP 2...9	
Address	
PROFINET IO	No function. <ul style="list-style-type: none"> The address is set via parameter P850.
EtherCAT	Setting the “Explicit Device Identification”. <ul style="list-style-type: none"> For switch position “OFF”: The address is set via parameter P850. If the Second Address is set via DIP switch, it cannot be controlled via the NORD parameters.
EtherNet/IP	Setting the last byte of the IP address. <ul style="list-style-type: none"> For switch position “OFF”: The address is set via parameter P850. Additionally: Set parameter P856 to setting “0” (“Address via P850”). The set IP address can be controlled via parameter P875.

DIP 10 TCP rights	NOTICE! Observe the functions specified below for setting the DIP switches!
PROFINET IO	No function. • The TCP rights are configured via the parameter P853 .
EtherCAT	Activating the FoE functionality for firmware updates. – “OFF” = Write and read permissions – “ON” = Read-only permissions • The TCP rights are configured via the parameter P853 .
EtherNet/IP	Activating the TCP functionality. – “OFF” = TCP ON , the TCP rights are configured via the parameter P853 . – “ON” = TCP Off (configuration of the TCP rights via the parameter P853 has no effect .)

DIP 11...12 Ethernet protocol (dialect)	
PROFINET IO	This DIP switch determines the used Ethernet protocol. In the DIP 11 = 0 and DIP 12 = 0 combination, the protocol can be switched via parameter P899 ( BU 2900).
EtherCAT	
EtherNet/IP	

LED indicators

The operating statuses of the bus interface are visualised using LED indicators.

No.	Name	Colour	Meaning
1	BUS	green	Device State
	DEV	red	Device Error
	ERR/NS	red	Ethernet Error
	RUN/MS	green	Ethernet State
2	Link	green	Link
	Act	yellow	Activity



LED Link, Act

LEDs labelled “Link” / “Act” (Link/Activity) indicate the status of the Internet interface.

Link (green LED)	Act (yellow LED)	Meaning
Off	Off	• No Ethernet connection (check cable connection)
On	Flashing (4 Hz)	• Ethernet connection is established and data is being transmitted
On	Off	• Ethernet connection is established. No data is being transmitted.

NORD-specific LED

The LED labelled "DEV" indicates the general device status.

DEV	Meaning
Green on	• Module is ok
Green on and red flashing (1 Hz)	• Frequency inverter in fault state
Green and red on	• Frequency inverter in update mode
Red and green flashing simultaneously	• Update files are transmitted via Ethernet

The LED labelled "BUS" indicates the status of communication at system bus level.

BUS	Meaning
Off	• No supply voltage
Green on	• Process data communication active, or frequency inverter's firmware update
Green flashing (2 Hz)	• No system bus frequency inverter available
Red and green flashing alternately (4 Hz)	• System bus in status "BUS Warning" because <ul style="list-style-type: none"> – no further CAN participant exists. – the CAN controller is in "Error Passive" state. – an EMC interference is present.
Red on	• System bus in state "BUS-OFF"

EtherCAT-specific LED

RUN	State	Meaning
Off	Init	• No communication of process data and parameters
Green flashing (4 Hz)	Pre-Operational	• Parameter communication active • No process data communication
Green single flash	Save Operational	• Parameter communication active • Restricted process data communication • No restrictions to actual values • Setpoints not evaluated
Green On	Operational	• Parameter communication active • Unrestricted parameter communication active

ERR	State	Meaning
Off	No Error	• EtherCAT functioning normally on the bus interface
Red flashing (4 Hz)	Invalid Configuration	• General EtherCAT configuration error, may be generated because of an incorrect XML file
Red single flash	Unsolicited State Change	• Bus interface has changed the EtherCAT state without authorisation
Red double flash	Application Watchdog Timeout	• EtherCAT or FI timeout (P513 or P151)

EtherNet/IP-specific LED

MS	Meaning
Off	• No mains or control voltage
Green On	• Bus interface working correctly
Green flashing (4 Hz)	• Bus interface not configured
Red flashing (4 Hz)	• Minor errors, faulty configuration
Red and Green flashing alternately (4 Hz)	• Power-up, self test

NS	Meaning
Off	• No mains or control voltage
Green On	• CIP connection available
Green flashing (4 Hz)	• IP address configured but no CIP connection available
Red flashing (4 Hz)	• Time-out An "exclusive owner connection" has a timeout error
Red and Green flashing alternately (4 Hz)	• Power-up, self test
Red On	• Double IP IP address used by the bus interface is used already.

PROFINET IO-specific LED

RUN	Meaning
Off	• No error
Red flashing (1 Hz)	• DCP signal is triggered via the bus.
Red on	• System error / alarm

ERR	Meaning
Off	• No errors
Red flashing (2 Hz)	• No data exchange
Red on	• No configuration or no physical connection

Parameter access and diagnosis

The NORDCON software from version 2.9.1 and higher or optional control units such as the SK PAR-3H ParameterBox provide convenient access to the parameters of the bus interface and allow status information to be read out. In addition, the NORDCON APP – in connection with the NORDAC ACCESS BT Bluetooth stick – offers a practical way of mobile and wireless maintenance as well as commissioning of NORD frequency inverters.

Access is via the RJ12 diagnostics socket of the frequency inverter. The prerequisite for this is that the bus interface is connected to the frequency inverter via the system bus.

When using EtherNet/IP and PROFINET IO, access is also possible via Ethernet (TCP). This is based on the prerequisite that IP addresses have been set and the necessary rights have been granted.

Direct access via the RJ12 diagnostic socket of the bus connection unit is also possible.

Further documentation and software (www.nord.com)

Software	Description
Device description files	Device characteristics and parameters

Software	Description
NORDCON	Parameterisation and diagnostic software

Document	Description
BU 0000	Description of NORDCON software
BU 0040	Parameter box manual
BU 0180	Manual for NORDAC BASE frequency inverters
BU 0200	Manual for NORDAC FLEX frequency inverters

Document	Description
TI 275274505	SK TIE4-M12-SYSM System bus output connection extension
TI 275274506	SK TIE4-M12-SYSS System bus input connection extension
TI 275274514	SK TIE4-M12-ETH Ethernet input/output connection extension
BU 0250	Manual for the NORDAC LINK frequency inverter
BU 2900	Manual for Industrial Ethernet bus communication