

EtherCAT®

EtherNet/IP™

PROFINET®

BU 2900 – en

Industrial Ethernet Bus module

Supplemental manual for frequency inverters





Read document and keep for future reference

Read this document carefully prior to performing any work on or putting the device into operation. It is essential to read and observe the instructions in this document. They serve as the prerequisite for smooth and safe operation and the fulfilment of any warranty claims.

Contact Getriebebau NORD GmbH & Co. KG if your questions regarding the handling of the device are not answered in this document or if you require further information.

The German version of this document is the original. The German document is always decisive. If this document is available in other languages, this will be a translation of the original document.

Keep this document in the vicinity of the device so that it is available if required.

Use the version of this documentation that is valid for your device at the time of delivery. You can find the currently valid version of the documentation under www.nord.com.

Please also note the following documents:

- Documentation for the frequency inverter
- Documentation for optional accessories
- Documentation for equipment which is attached or provided.

Please contact [Getriebebau NORD GmbH & Co. KG](http://www.nord.com) if you require further information.

Table of Contents

1	Introduction	7
1.1	General	7
1.1.1	Documentation	7
1.1.2	Document history	7
1.1.3	Copyright notice	7
1.1.4	Publisher	7
1.1.5	About this manual	8
1.2	Other applicable documents	8
1.3	Presentation conventions	8
1.3.1	Warning information	8
1.3.2	Other information	8
1.3.3	Text markings	9
1.3.4	Abbreviations	9
2	Safety	11
2.1	Intended use	11
2.2	Selection and qualification of personnel	11
2.2.1	Qualified personnel	11
2.2.2	Qualified electrician	11
2.3	Safety information	12
3	Basics	13
3.1	Transmitted data	13
3.1.1	Control word	14
3.1.2	Status word	15
3.1.3	Frequency inverter status machine	16
3.1.4	Setpoints and actual values	20
3.2	NORD system bus	21
3.2.1	NORD system bus participants	21
3.2.2	Physical structure	22
3.2.3	Remote maintenance	23
3.3	EtherCat basics	23
3.3.1	Characteristics	24
3.3.2	Topology	24
3.3.3	Bus protocol	25
3.3.4	Hot-Connect function	25
3.3.5	EtherCAT state machine (ESM)	26
3.3.6	Transfer of process data	27
3.3.6.1	Process data telegrams	27
3.3.7	Parameter data transmission	28
3.3.7.1	EtherCAT parameters (CoE directory)	28
3.3.7.2	SDO error codes	29
3.3.8	FoE functionality	30
3.4	EtherNet/IP basics	31
3.4.1	Characteristics	31
3.4.2	Topology	32
3.4.3	Bus protocol	33
3.4.4	Assembly Object	34
3.4.5	Parameter data transmission	34
3.5	PROFINET IO basics	36
3.5.1	Characteristics	36
3.5.2	Topology	37
3.5.3	Bus protocol	38
3.5.4	Application data structure	41
3.5.5	Transfer of process data	43
3.5.5.1	Process data telegrams	44
3.5.6	Parameter data transmission	46
3.5.6.1	Procedure of the acyclic parameter data exchange (records)	47
3.5.6.2	Data sets for acyclic parameter requests	48
3.5.6.3	Format of parameter requests	48
3.5.6.4	Parameter ID PKE	48
3.5.6.5	Parameter index IND	50

3.5.6.6	Parameter value PWE	51
3.5.7	Examples of data record transfer.....	52
3.5.7.1	Telegram structure for parameterisation via PPO1 or PPO2	55
4	Initial setup	56
4.1	Setting the field bus protocol.....	56
4.2	Download device description file.....	56
4.3	Setting up EtherCAT	57
4.3.1	Automatic device detection.....	57
4.4	Setting up the EtherNet/IP	58
4.4.1	Automatic device detection.....	58
4.4.2	EtherNet/IP field bus address.....	58
4.5	Setting up PROFINET IO.....	60
4.6	Firmware update.....	63
4.6.1	Basic information on the firmware update	63
4.6.2	Firmware update with EtherCAT.....	63
4.6.3	Firmware update with EtherNet/IP or PROFINET IO.....	65
4.7	Specify data format for process data.....	66
5	Parameter.....	67
5.1	NORD standard parameters	68
5.2	Field bus-specific standard parameters	72
5.2.1	EtherCAT standard parameters.....	72
5.2.2	EtherNet/IP standard parameters.....	72
5.2.3	PROFINET IO standard parameters.....	74
5.3	NORD information parameters.....	76
5.4	Field bus-specific information parameters.....	79
5.4.1	EtherNet/IP information parameters	79
5.4.2	PROFINET IO information parameters.....	80
5.5	Frequency inverter parameter settings.....	82
6	Error monitoring and error messages.....	83
7	Additional information	84
7.1	Topology overview	84
7.1.1	Linear topology.....	84
7.1.2	Star topology	85
7.1.3	Ring topology.....	86
7.1.4	Tree topology.....	87
8	Appendix.....	88
8.1	Repair information.....	88
8.2	Documents and software	89

List of illustrations

Figure 1: Frequency inverter status machine.....	16
Figure 2: Example of the structure of a NORD system bus	21
Figure 3: Remote maintenance via Internet (schematic diagram)	23
Figure 4: EtherCAT telegram.....	25
Figure 5: EtherCAT state machine (ESM)	26
Figure 6: CIP adaptation with EtherNet/IP according to the OSI layer model.....	31
Figure 7: Ethernet telegram (minimum frame length 64 Byte).....	33
Figure 8: PROFINET IO communication via Application Relation AR	37
Figure 9: PROFINET IO telegram (communication within a sub-net).....	38
Figure 10: PROFINET IO data cycle times.....	40
Figure 11: Application area structure – Telegram traffic.....	42
Figure 12: Example – PROFINET IO device model.....	43
Figure 13: Procedure of the acyclic PROFINET IO parameter data exchange.....	47
Figure 14: Linear topology (example).....	84
Figure 15: Star topology (example)	85
Figure 16: Ring topology (example).....	86
Figure 17: Tree topology (example).....	87

1 Introduction

1.1 General

1.1.1 Documentation

Designation:	BU 2900
Part number:	6082902
Series:	Bus communication with the bus interface Industrial Ethernet for
	<ul style="list-style-type: none"> • EtherCAT® • EtherNet/IP® • PROFINET® IO

1.1.2 Document history

Edition	Order number	Software version	Remarks
BU 2900 , November 2021	6082902 / 4721	V 1.0 R0	• First issue
BU 2900 , September 2022	6082902 / 3722	V 1.0 R7	• General corrections
BU 2900 , October 2023	6082902 / 4023	V 1.0 R8	• General corrections • Adjustments of information on the firmware update • Supplementation of type SK TU4-ETH-... modules
BU 2900 , November 2023	6082902 / 4623	V 1.0 R8	• Adjustments of information on the firmware update via FoE

1.1.3 Copyright notice

As an integral component of the device or the function described here, this document must be provided to all users in a suitable form.

Any editing or amendment or other utilisation of the document is prohibited.

1.1.4 Publisher

Getriebebau NORD GmbH & Co. KG

Getriebebau-Nord-Straße 1
22941 Bargteheide, Germany
<http://www.nord.com/>
Tel.: +49 (0) 45 32 / 289-0
Fax: +49 (0) 45 32 / 289-2253

1.1.5 About this manual

This manual is intended to assist you with the installation of bus interfaces from series Industrial Ethernet from Getriebebau NORD GmbH & Co. KG into a field bus system. It is intended for qualified electricians who plan, install and set up the field bus system. The information in this manual assumes that the qualified electricians who are entrusted with this work are familiar with the technology of the field bus system and programmable logic controllers (PLC).

The information in this manual only contains information and descriptions for bus interfaces and frequency inverters from Getriebebau NORD GmbH & Co. KG. It does not contain any descriptions of the controllers and the necessary software for other manufacturers.

1.2 Other applicable documents

This manual is only valid in combination with the Technical Information for the bus interface which is used and the operating instructions for the relevant frequency inverter. Only these documents contain all of the information that is required for safe commissioning of the bus interface module and the frequency inverter. A list of the documents can be found in  Section 8.2 "Documents and software".

The "Technical Information" (TI) for the bus interface and the manuals (BU) for the NORD frequency inverters can be found under www.nord.com.

1.3 Presentation conventions

1.3.1 Warning information

DANGER

Indicates an immediate danger, which may result in death or very serious injury if it is not avoided.

WARNING

Indicates a dangerous situation, which may result in death or very serious injury if it is not avoided.

CAUTION

Indicates a dangerous situation, which may result in minor injuries if it is not avoided.

NOTICE!

Indicates a situation, which may result in damage to the product or the environment if it is not avoided.

1.3.2 Other information

Information

Indicates hints for use and especially important information to ensure reliability of operation.

1.3.3 Text markings

The following markings are used to differentiate between various types of information:



Text

Type of information	Example	Marking
Instructions	1. 2.	Instructions for actions whose sequence must be complied with are numbered sequentially.
Bullet points	•	Bullet points are marked with a dot.
Parameters	P850	Parameters are indicated by the prefix "P", a three-digit number and bold type.
Arrays	[-01]	Elements of arrays are indicated by square brackets.
Factory settings	{ 0.0 }	Factory settings are indicated by curly brackets.
Software descriptions	"Cancel"	Menus, fields, buttons and tabs are indicated by quotation marks and bold type.

Numbers

Type of information	Example	Marking
Binary numbers	100001b	Binary numbers are indicated by the suffix "b"
Hexadecimal numbers	0000h	Hexadecimal numbers are indicated by the suffix "h"

Symbols used

Type of information	Example	Marking
Cross-reference	 Section	Internal cross-reference A mouse click on the text calls up the stated point in the document.
	 Supplementary manual	External cross-reference
Hyperlink	http://www.nord.com/	References to external websites are indicated in blue and underlined. A mouse click calls up the website.

1.3.4 Abbreviations

Abbreviations used in this manual

Abbreviation	Meaning
AK	Request ID/response ID
AR	Application Relation
CAN	Controller Area Network
CIP	Common Industrial Protocol, application protocol for EtherNet/IP
CoE	CAN over EtherCAT
CR	Communication Relation
DAP	Device Access Point
DHCP	Dynamic Host Configuration Protocol, communication protocol for managing IP addresses in a network
DIP	Dual In-Line Package (= double row housing), compact switch block
DLR	Device Level Ring, EtherNet/IP option for ring topologies
EMC	Electromagnetic compatibility
FI	Frequency inverter

Abbreviation	Meaning
FoE	File over EtherCAT
HMI	Human-machine interface – Interface between humans and machines
ID	Identifier
IND	Index
IP	Internet protocol
I/O	Input, Output
IW	Actual value
NMT	Network management
PDO	Process data object
PKE	Parameter ID
PKW	Parameter ID value
PNU	Parameter number
PPO	Parameter/Process Data Object
PReq	Poll Request, call-up of cyclic data from CN
PRes	Poll Response, transmission of cyclic data from CN
PWE	Parameter value
PZD	Process data
Rx	Receive
SDO	Service data object
SoA	Start of Asynchronous, indicates the start of the asynchronous phase
SoC	Start of Cycle, start of a new transmission cycle
PLC	Programmable logic controller
CTW	Control word
SW	Setpoint
TCP	Transmission Control Protocol
Tx	Transmit
UCMM	Unconnected Message Manager, function of an EtherNet/IP bus participant for the transmission and reception of Explicit Messages
UDP	User Datagram Protocol
STW	Status word

2 Safety

2.1 Intended use

The Industrial Ethernet bus interfaces from Getriebebau NORD GmbH & Co. KG are interfaces for the Industrial Ethernet field bus communication which must only be used in the following frequency inverters from Getriebebau NORD GmbH & Co. KG.

Bus interface	Frequency inverter
SK CU4-ETH(-C)	NORDAC <i>BASE</i> , SK 180E series
SK TU4-ETH(-C)	NORDAC <i>FLEX</i> , SK 200E series
SK TU4-ETH-M12(-C)	NORDAC <i>LINK</i> , SK 250E-FDS series

The Industrial Ethernet bus interfaces from Getriebebau NORD GmbH & Co. KG are used for communication between the frequency inverters and a PLC in an operator's EtherNet/IP, EtherCAT or PROFINET IO field bus system.

Any other use of the bus interface is deemed to be incorrect use.

2.2 Selection and qualification of personnel

The bus interface may only be installed and started up by qualified electricians. These must possess the necessary knowledge with regard to the technology of the field bus system, as well as configuration software and the controller (bus master) which are used.

In addition, the qualified electricians must also be familiar with the installation, commissioning and operation of the bus interfaces and the frequency inverters as well as all of the accident prevention regulations, guidelines and laws which apply at the place of use.

2.2.1 Qualified personnel

Qualified personnel includes persons who due to their specialist training and experience have sufficient knowledge in a specialised area and are familiar with the relevant occupational safety and accident prevention regulations as well as the generally recognised technical rules.

These persons must be authorised to carry out the necessary work by the operator of the system.

2.2.2 Qualified electrician

An electrician is a person who, because of their technical training and experience, has sufficient knowledge with regard to

- Switching on, switching off, isolating, earthing and marking power circuits and devices,
- Proper maintenance and use of protective devices in accordance with defined safety standards.
- Emergency treatment of injured persons.

2.3 Safety information

Only use bus interfaces and frequency inverters from NORD DRIVESYSTEM Group for their intended purpose,  Section 2.1 "Intended use".

To ensure safe operation of the bus interface, observe all of the instructions in this manual, and in particular the warning information in the other applicable documents,  Section 8.2 "Documents and software".

Only commission bus interfaces and frequency inverters in their technically unchanged form and not without the necessary covers. Take care that all connections and cables are in good condition.

Work on and with bus interfaces and frequency inverters must only be carried out by qualified personnel,  Section 2.2.1 "Qualified personnel".

3 Basics

The prerequisite for integration of a frequency inverter in a field bus system is an interface which enables communication between them. This interface consists of hardware components (including elements for the electrical connection to a field bus system and a communication processor) and firmware which allows the frequency inverter to communicate with the field bus protocol.

This bus interface is equipped for connection to the following Ethernet-based field bus systems:

- EtherCAT
- EtherNet/IP
- PROFINET IO



The supported field bus protocol is set via a parameter or with a DIP switch on the module.

3.1 Transmitted data

The below data is transmitted in all bus systems.

3.1.1 Control word

The control word (CTW) is the first word of a process data telegram, which is sent from the bus master to the frequency inverter (order telegram) To switch the drive to operational readiness, the frequency inverter must be set to the “Ready to switch-on” state by transmitting the first control command “047Eh” (“10001111110b”).

Bit	Designation	Value	Control command	Priority ¹⁾															
0	Ready for operation	0	Reverse running with braking ramp, voltage enabled at f = 0 Hz (ready for operation).	3															
		1	Set the frequency inverter as ready for operation	5															
1	Voltage disable	0	Switch off the frequency inverter output voltage (the frequency inverter goes into the state “Switch-on inhibit”).	1															
		1	Cancel “Voltage disable“.	—															
2	Quick stop	0	Quick stop with programmed quick stop time. Voltage enabled at f = 0 Hz (the frequency inverter goes into the status “Switch-on inhibit”).	2															
		1	Cancel the operating condition “Quick stop“.	—															
3	Enable operation	0	Voltage disable: Switch off the frequency inverter output voltage (the frequency inverter goes into the state “Ready to switch on”).	6															
		1	Enable output voltage. Acceleration of the frequency inverter to the present set point.	4															
4	Enable pulses	0	Set ramp generator to 0, no voltage enabled at f = 0 Hz (the frequency inverter remains in the “Operation enabled” state).	—															
		1	Enable ramp generator.	—															
5	Enable ramp	0	Freeze the current setpoint specified by the ramp generator (maintain the frequency).	—															
		1	Enable setpoint on the ramp generator.	—															
6	Setpoint enabled	0	Set selected setpoint on the ramp generator to 0.	—															
		1	Activate selected setpoint on the ramp generator.	—															
7	Acknowledge error (0→1)	0	With the change from 0 to 1, faults which are no longer active are acknowledged.	7															
		1	Note: If a digital input has been programmed for the "Ack.fault" function, this bit must not be permanently set to 1 via the bus, as otherwise flank evaluation would be prevented.	—															
8	Start function 480.11	0		—															
		1	Bus bit 8 of the control word is set  Parameter P480 in the frequency inverter manual.	—															
9	Start function 480.12	0		—															
		1	Bus bit 9 of the control word is set  Parameter P480 in the frequency inverter manual.	—															
10 ²⁾	Control data valid	0	The transmitted process data is invalid.	—															
		1	The bus master is transmitting valid process data.	—															
11 ³⁾	CW direction of rotation On	0		—															
		1	Switch on the CW direction of rotation.	—															
12 ³⁾	CCW direction of rotation On	0		—															
		1	Switch on the CCW direction of rotation (priority).	—															
13	Reserved																		
14	Parameter set Bit 0 On	0	<table border="1" style="display: inline-table; vertical-align: middle;"> <thead> <tr> <th>Bit 15</th> <th>Bit 14</th> <th>Activated parameter set</th> </tr> </thead> <tbody> <tr> <td>0</td> <td>0</td> <td>Parameter set 1</td> </tr> <tr> <td>0</td> <td>1</td> <td>Parameter set 2</td> </tr> <tr> <td>1</td> <td>0</td> <td>Parameter set 3</td> </tr> <tr> <td>1</td> <td>1</td> <td>Parameter set 4</td> </tr> </tbody> </table>	Bit 15	Bit 14	Activated parameter set	0	0	Parameter set 1	0	1	Parameter set 2	1	0	Parameter set 3	1	1	Parameter set 4	—
		Bit 15		Bit 14	Activated parameter set														
0	0	Parameter set 1																	
0	1	Parameter set 2																	
1	0	Parameter set 3																	
1	1	Parameter set 4																	
1																			
15	Parameter set Bit 1 On	0																	
		1																	



1) If several control bits are set simultaneously, the priority specified in this column applies.

2) The frequency inverter only interprets the telegram as valid and the setpoints transmitted via the field bus are only set if control bit 10 is set to 1.

3) If Bit 12 = 0, “CW direction of rotation On” applies.
If Bit 12 = 1, “CCW direction of rotation On” applies, regardless of Bit 11.

3.1.2 Status word

The status word (ZSW) is the first word of a process data telegram which is sent from the frequency inverter to the bus master (response telegram). With the status word, the status of the frequency inverter is reported to the bus master. As the response to the control word command "047Eh" the frequency inverter typically responds with "0B31h" ("101100110001b") and therefore indicates the status "Ready to switch-on".

Bit	Meaning	Value	Status message															
0	Ready to switch-on	0																
		1	Initialisation completed, charging relay switched on, output voltage disabled															
1	Ready for operation	0	No switch-on command present, or there is a fault, of the command "Disable voltage" or "Emergency stop" is present, or the status is "Switch-on inhibit".															
		1	There is a switch-on command and there is no fault. The inverter can be started with the command "Enable operation"															
2	Operation enabled	0																
		1	The output voltage is enabled; ramp of the frequency inverter up to the existing setpoint															
3	Fault	0																
		1	Drive unit defective and therefore "Not ready for operation". After acknowledgement, the frequency goes into status "Switch-on inhibit".															
4	Voltage enabled	0	"Disable voltage" command present.															
		1																
5	Emergency stop	0	"Emergency stop" command present.															
		1																
6	Switch-on inhibit	0																
		1	With the command "Standby" the frequency goes into status "Ready to switch-on".															
7	Warning active	0																
		1	Drive operation continues, no acknowledgement necessary															
8	Setpoint reached	0	Actual value does not correspond to the setpoint With use of POSICON: Setpoint position not reached.															
		1	Actual value matches the setpoint (setpoint reached) With use of POSICON: setpoint position has been reached															
9	Bus control active	0	Control on local device active															
		1	The master has been requested to take over control.															
10	Start function 481.9	0																
		1	Bus bit 10 of the status word is set  Parameter P481 in the frequency inverter manual.															
11	Rotation right is on	0																
		1	The frequency inverter output voltage has a right-hand rotation field.															
12	Rotation left is on	0																
		1	The frequency inverter output voltage has a left-hand rotation field.															
13	Start function 481.10	0																
		1	Bus bit 13 of the status word is set  Parameter P481 in the frequency inverter manual.															
14	Parameter set Bit 0 ON	0	<table border="1"> <thead> <tr> <th>Bit 15</th> <th>Bit 14</th> <th>parameter set, that is active</th> </tr> </thead> <tbody> <tr> <td>0</td> <td>0</td> <td>Parameter set 1</td> </tr> <tr> <td>0</td> <td>1</td> <td>Parameter set 2</td> </tr> <tr> <td>1</td> <td>0</td> <td>Parameter set 3</td> </tr> <tr> <td>1</td> <td>1</td> <td>Parameter set 4</td> </tr> </tbody> </table>	Bit 15	Bit 14	parameter set, that is active	0	0	Parameter set 1	0	1	Parameter set 2	1	0	Parameter set 3	1	1	Parameter set 4
		Bit 15		Bit 14	parameter set, that is active													
0	0	Parameter set 1																
0	1	Parameter set 2																
1	0	Parameter set 3																
1	1	Parameter set 4																
1																		
15	Parameter set Bit 1 On	0																
		1																

3.1.3 Frequency inverter status machine

The frequency inverter passes through a status machine. Changes between various states are triggered automatically or by control commands in the process data control word. The actual status is returned in the process data status word.

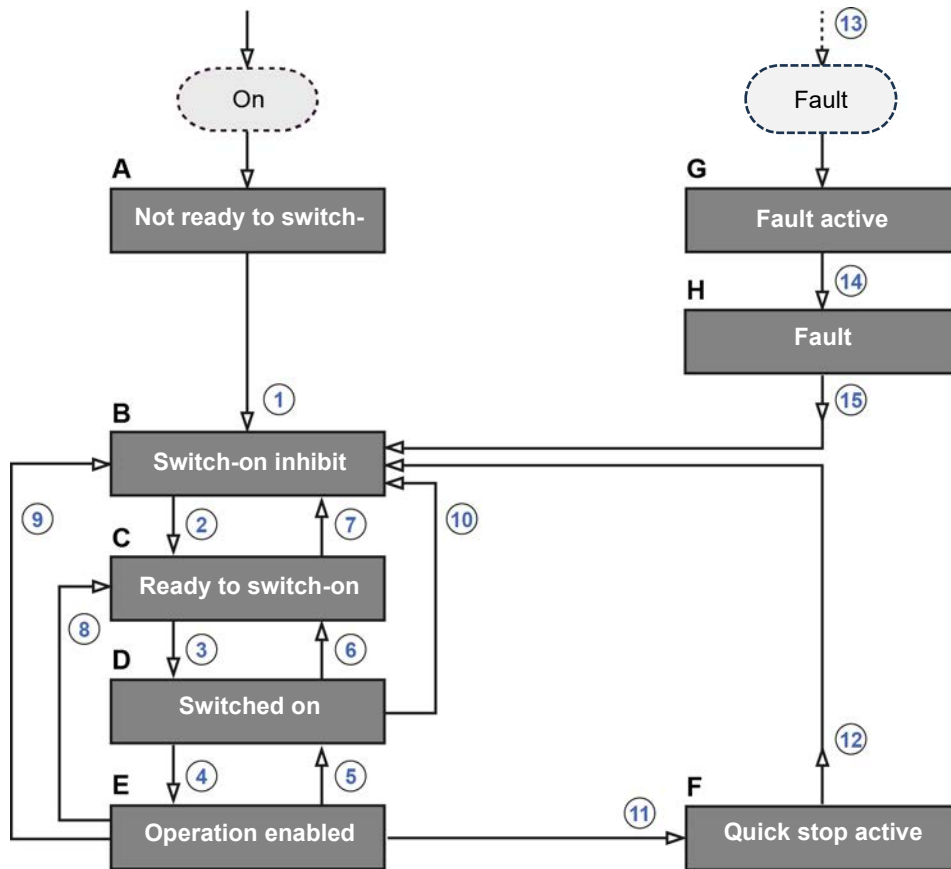

Figure 1: Frequency inverter status machine

Item	Meaning
A...H	Frequency inverter statuses (📖 Table “Frequency inverter statuses”)
1...15	Status transitions (📖 Table “Status transitions”)

Frequency inverter statuses

Status		Description
A	Not ready to switch-on	Initial state after switching on the frequency inverter. As soon as the loading relay engages, the frequency inverter automatically changes to the status "Switch-on inhibit".
B	Switch-on inhibit	Second status after switching on the frequency inverter, which can only be exited with the control command "Shut-down". The charging relay is switched on.
C	Ready to switch-on	In this status, initialisation of the frequency inverter is complete. The output voltage is blocked.
		<p>i Information</p> <p>During the initialisation process the response to a bus master telegram does not yet contain the response to the control command which has been issued. On the basis of the response from the bus participant, the control system must determine whether the control command has been executed.</p>
D	Switched on	Frequency inverter ready for operation.
E	Operation enabled	The frequency inverter receives and processes setpoint values.
F	Quick stop active	The emergency stop function is being executed (the drive is stopped), and the frequency inverter changes to the status "Switch-on inhibit".
W	Fault active	If an error occurs, the frequency inverter changes to this status and all functions are blocked.
H	Fault	After processing of the response to the fault (fault active) the frequency inverter changes to this status, which can only be exited with the control command "Acknowledge fault".

Status transitions

Triggered status transition		Control command	Bit 7...0 of the control word ¹⁾							
			7	6	5	4	3	2	1	0
1	From "Not ready to switch-on" to "Switch on inhibit"	—	—							
	Automatically, after activation of the charging relay									
2	From "Switch-on inhibit" to "Ready to switch-on"	Shut down	X	X	X	X	X	1	1	0
3	From "Ready to switch-on" to "Switched on"	Switch on	X	X	X	X	X	1	1	1
4	From "Switched on" to "Operation enabled"	Enable operation	X	1	1	1	1	1	1	1
	Output voltage is enabled									
5	From "Operation enabled" to "Switched on"	Disable operation	X	X	X	X	0	1	1	1
	The output voltage is disabled									
6	From "Switched on" to "Ready to switch-on"	Shut down	X	X	X	X	X	1	1	0
	Voltage enabled at "f = 0 Hz"									
7	From "Ready to switch-on" to "Switch-on inhibit"	Voltage disable	X	X	X	X	X	X	0	X
		Quick stop	X	X	X	X	X	0	1	X
8	From "Operation enabled" to "Ready to switch-on"	Shut down	X	X	X	X	X	1	1	0
9	From "Operation enabled" to "Switch on inhibit"	Voltage disable	X	X	X	X	X	X	0	X
10	From "Switched on" to "Switch on inhibit"	Voltage disable	X	X	X	X	X	X	0	X
		Quick stop	X	X	X	X	X	0	1	X
11	From "Operation enabled" to "Quick stop active"	Quick stop	X	X	X	X	X	0	1	X
12	From "Quick stop active" to "Switch on inhibit"	Voltage disable	X	X	X	X	X	X	0	X
13	Automatically, after the occurrence of a fault from any status	—	—							
14	Automatically, after completion of the fault response ("Fault active")	—	—							
15	End fault	Acknowledge error	0	X	X	X	X	X	X	X
			→							
			1	X	X	X	X	X	X	X

X = The bit status (0 or 1) is not important for achieving the status. Please also note the list of control bits.

¹⁾ Complete list of control bits (Bit 0...15)  Section 3.1.1 "Control word".

Information

Control bit 10

Control bit 10 "Control data valid" must always be set to 1. Otherwise the process data will not be evaluated by the frequency inverter.

Decoded frequency inverter statuses

Status	Status bits ¹						
	6	5	4	3	2	1	0
Not ready to switch-on	0	X	X	0	0	0	0
Switch-on inhibit	1	X	X	0	0	0	0
Ready to switch-on	0	1	1	0	0	0	1
Switched on	0	1	1	0	0	1	1
Operation enabled	0	1	1	0	1	1	1
Fault	0	X	X	1	0	0	0
Fault active	0	X	X	1	1	1	1
Quick stop active	0	0	1	0	1	1	1

¹⁾ Complete list of status bits (Bit 0...15)  Section 3.1.2 "Status word".

3.1.4 Setpoints and actual values

Setpoints (from the bus master to the frequency inverter) and actual values (from the frequency inverter to the bus master) are specified via the following parameters of the frequency inverter:

Transmission direction	Process value	Parameter
to bus interface	Setpoint 1	P546, Array [-01]
	Setpoint 2	P546, Array [-02]
	Setpoint 3	P546, Array [-03]
from bus interface	Actual value 1	P543, Array [-01]
	Actual value 2	P543, Array [-02]
	Actual value 3	P543, Array [-03]

Setpoints and actual values are transmitted by three different methods:

Percentage transmission

The process value is transmitted as an integer with a value range of -32768 to 32767 (8000h to 7FFFh). The value "16384" (4000h) corresponds to 100%. The value "-16384" (C000h) corresponds to -100%.

For frequencies, the 100% value corresponds to parameter **P105 Maximum frequency** of the frequency inverter. For current, the 100% value corresponds to parameter **P112 Torque current limit** of the frequency inverter.

Frequencies and currents result from the following formulae:

$$Frequency = \frac{Value^* \times P105}{16384} \qquad Current = \frac{Value^* \times P112}{16284}$$

* 16-bit setpoint or actual value, which is transmitted via the bus.

Binary transmission

Inputs and outputs as well as digital input bits and bus output bits are evaluated bit-wise.

Transmission of positions

In the frequency inverter, positions have a value range of -50000.00 to 50000.00 rotations. A rotation of the motor can be subdivided into a maximum of 1000 increments. The subdivision depends on the encoder which is used.

The 32-bit value range is divided into a "Low" and a "High" word, so that two setpoints or actual values are required for the transmission.

Transmission direction	Transmitted data			
	1st word	2nd word	3rd word	4th word
to bus interface	Control word	32 Bit setpoint		Setpoint 3
from bus interface	Status word	Actual value 1	32-bit actual value	

Only the "Low" word for the position can also be transmitted. This results in a limited value range from 32,767 to -32,768 rotations. This value range can be extended with the ratio factor (**Parameter P607 Ratio** and **P608 Reduction Ratio**), however this reduces the resolution accordingly.

3.2 NORD system bus

The communication between bus interface and frequency inverters from Getriebebau NORD GmbH & Co. KG is carried out via a separate NORD system bus. The NORD system bus is a CAN field bus; communication is via the CANopen protocol.

One or more frequency inverters can be accessed via a bus interface in the field bus system.

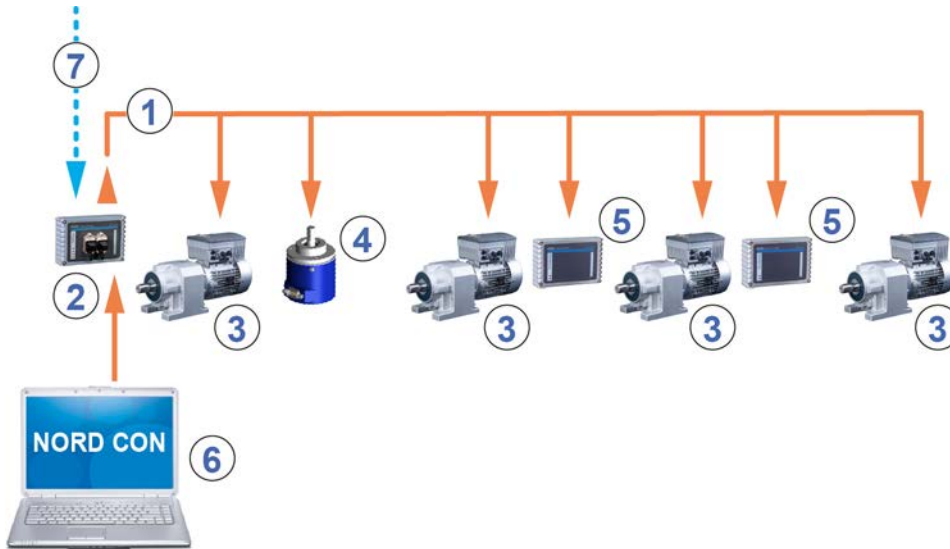

Figure 2: Example of the structure of a NORD system bus

Item	Description
1	NORD system bus (CAN field bus)
2	Bus interface
3	Frequency inverter
4	Absolute encoder
5	Input/output extension
6	NORDCON computer (on Windows® based PC, on which the NORDCON parameterisation and control software is installed)
7	Field bus

3.2.1 NORD system bus participants

Up to 4 frequency inverters with the associated absolute encoders can be integrated into the NORD system bus. All participants on the NORD system bus must be assigned with a unique address (Node ID). The addresses of the frequency inverters are set with parameter **P515 [-01]** “CAN bus address”.

The address of connected standard absolute encoders from NORD is set via DIP switches. Absolute encoders must be assigned directly to a frequency inverter. This is carried out using the following equation:

$$\text{Absolute encoder address} = \text{CAN bus address of the frequency inverter} + 1$$

This results in the following matrix:

Device	F11	AE1	F12	AE2	...
Node ID (CAN bus address)	32	33	34	35	...

The termination resistor must be activated on the first and last participant in the system bus ( Frequency inverter manual). The bus speed of the frequency inverter must be set to “250 kbaud” (**P514** “CAN bus baud rate”). This also applies to any absolute encoders which are connected.

3.2.2 Physical structure

Standard	CAN
Physical design	2x2, twisted pair, shielded, stranded wires, wire cross-section $\geq 0.25 \text{ mm}^2$ (AWG23), surge impedance approx. 120 Ω
Bus length	max. 20 m total expansion (network), max. 20 m between 2 subscribers,
Structure	preferably linear
Spur cables	possible, (max. 6 m)
Termination resistors	120 Ω , 250 mW at both ends of a system bus (switchable via DIP switches)
Baud rate	250 kBaud

The CAN_H and CAN_L signals must be connected using a twisted pair of wires. The GND potentials are connected using the second pair of wires.



3.2.3 Remote maintenance

The frequency inverter and all Getriebebau NORD GmbH & Co. KG devices connected to the NORD system bus can also be accessed via LAN or Internet for maintenance purposes.

Information

Remote maintenance is not possible if EtherCAT is used.

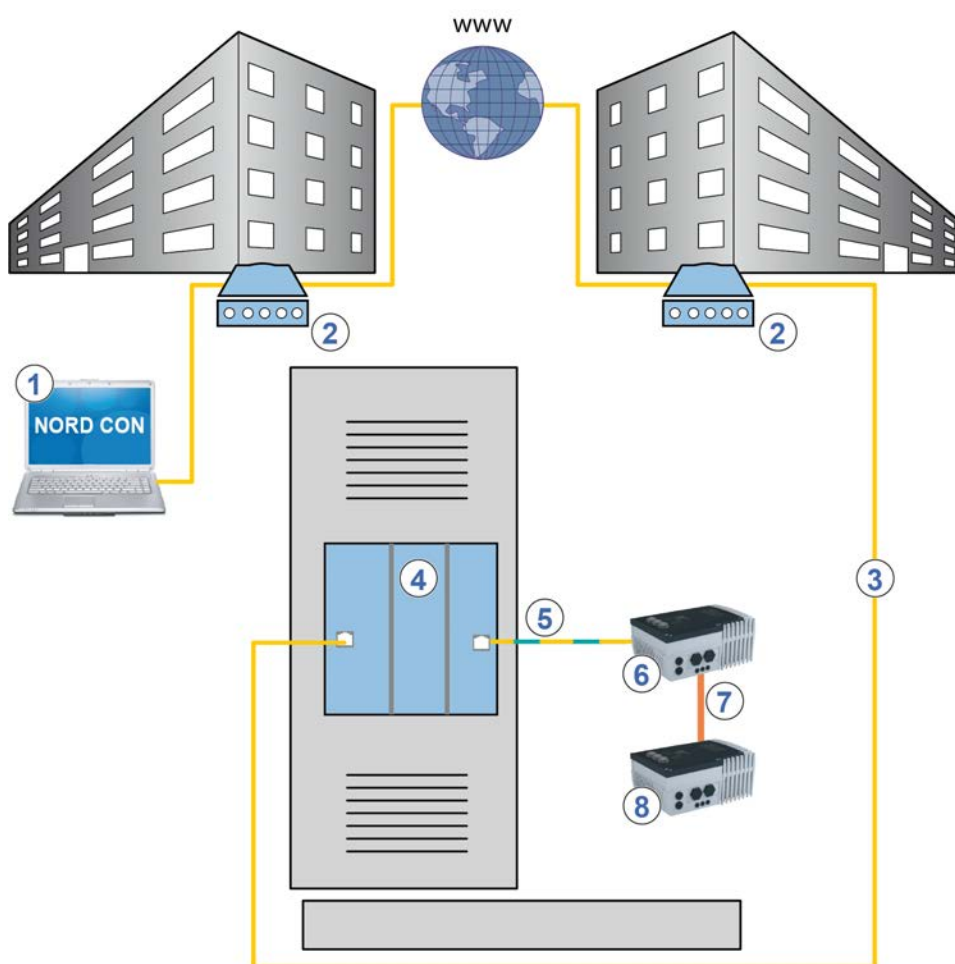

Figure 3: Remote maintenance via Internet (schematic diagram)

Item	Description
1	NORDCON software
2	Modem
3	LAN
4	EtherCAT master (comprises gateway and PLC)
5	Field bus
6	NORDAC FLEX frequency inverter
7	NORD system bus
8	NORDAC FLEX frequency inverter

3.3 EtherCat basics

3.3.1 Characteristics

EtherCAT (**E**thernet **C**ontrol **A**utomation **T**echnology) is a real-time Ethernet. It uses standard frames and the physical layers of Ethernet standard IEEE 802.3. EtherCAT is specified in the IEC 61158 standard.

Each EtherCAT slave only extracts the data which is intended for it, when the telegram sent by the EtherCAT master runs through. Output data is also inserted during the telegram's run-through. At the same time, the telegram is already forwarded with a slight delay (a few nanoseconds). The EtherCAT slave identifies the commands which are intended for it and executes them. The final EtherCAT slave returns the fully processed telegram so that the first EtherCAT slave can send it to the EtherCAT master – like a response telegram.

Addressing of EtherCAT slaves is not required. The EtherCAT master performs this automatically according to the physical bus connection sequence.

Performance description

Standards	IEC 61158, IEC 61784, ISO 15745, SEMI E54.20
Possible number of bus participants	65,535
Transfer rate	100 MBits (Fast Ethernet, full duplex)
Update time	1,000 FI axes (per 8-byte input and output data) in 1 ms
Link Lost	Is supported
Wiring	Standard Ethernet cable CAT 5 or better
Cable length	Max. 100 m between two nodes

3.3.2 Topology

The following topologies are supported:

- Linear topology
- Star topology
- Ring topology
- Tree topology

3.3.3 Bus protocol

The EtherCAT application data is embedded in standard Ethernet frames. During process data transfers, an EtherCAT frame is identified via the “0x88A4” ID in the “Ethertype” type field.

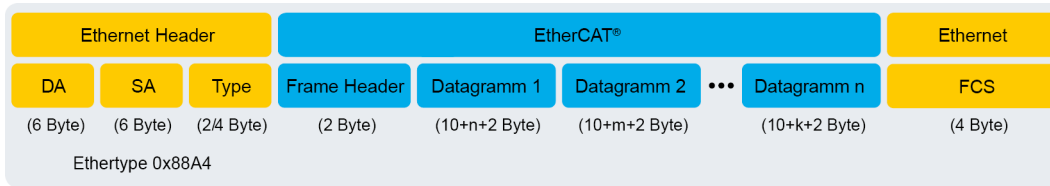

Figure 4: EtherCAT telegram

	Designation	Description
Ethernet header	DA	Destination Address = destination address of EtherCAT frames
	SA	Source Address = source address of EtherCAT frames
	Type	Type of EtherCAT frame (Ethertype 0x88A4)
EtherCAT	Frame Header	Information on the length of datagrams within the EtherCAT frame and type of datagrams
	Datagram	15 datagrams at the maximum, consisting of a header, data to be read or written, and a working counter
Ethernet	FCS	Checksum of the EtherCAT frames

The EtherCAT telegram can consist of several datagrams (EtherCAT commands). The datagram states which type of access the bus master may perform in the bus system (read, write, read and write, access to one or more EtherCAT slaves). Each datagram addresses a specific area of the logical process map, which can be up to 4 gigabytes in size. During bus system start-up, each EtherCAT slave is assigned with one or more unique addresses. Several EtherCAT slaves with one address within the same area can thus be addressed via one single datagram.

3.3.4 Hot-Connect function

In the field of EtherCAT “Hot Connect” designates the removal or addition of EtherCAT slaves in the ongoing bus operation. This can be done by switching off/on the EtherCAT slave, or by disconnecting/connecting parts of the network.

Usually, the EtherCAT master assigns the addresses to the bus participants according to their physical sequence in the field bus. Without the Hot-Connect function, the EtherCAT master would need to readapt its bus configuration with every switching on or off of an EtherCAT slave.

EtherCAT slaves that have been configured for the Hot-Connect function must be clearly identifiable. Therefore, EtherCAT slaves can be removed from or added to the field bus system – individually or in the form of a Hot-Connect group – anytime and without an adaptation of the PLC project. Different configuration levels of the EtherCAT field bus system can be operated with one single PLC project.

Configuration is carried out through setting an address (“Second Address”) via DIP switches or via parameter **P850** (📖 Section 5.2.1 "EtherCAT standard parameters") which is read when switching on the frequency inverter.

3.3.5 EtherCAT state machine (ESM)

When starting up the bus system, the bus interface runs through the EtherCAT state machine (ESM). Switching between the individual statuses is performed by the EtherCAT master.

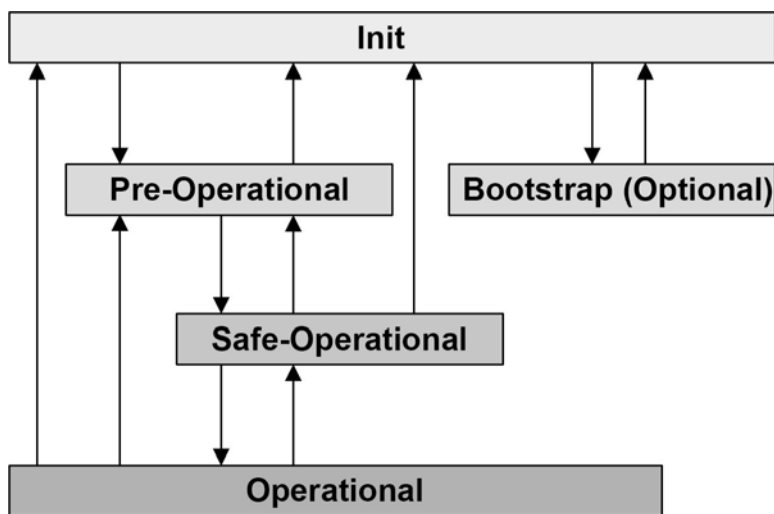

Figure 5: EtherCAT state machine (ESM)

Status	Description
Init	Initialisation phase: <ul style="list-style-type: none"> • No communication of process data and parameters • Device detection possible via field bus scan
Pre-Operational	Field bus active: <ul style="list-style-type: none"> • Parameter communication possible • No process data communication
Safe-Operational	<ul style="list-style-type: none"> • Parameter communication possible • Process data communication possible to a limited extent: Actual values are sent, setpoints are in status “Safe” and are not evaluated
Operational	Normal operation: <ul style="list-style-type: none"> • Parameter communication active • Process data communication active
Bootstrap	Recommended for firmware updates <ul style="list-style-type: none"> • No process data communication • Only File Access over EtherCAT (FoE) protocol possible

3.3.6 Transfer of process data

The control word (CTW) and up to 5 setpoints (SW) are transferred from the EtherCAT master to the bus interface or frequency inverter, which is connected to the bus interface via the system bus, and the status word (STW) and up to 5 actual values (IW) are transferred from the frequency inverter to the EtherCAT master as process data.

Transmission direction		PZD				
From	To	CTW	SW	STW	IW	I/O
EtherCAT master	Frequency inverter 1 via bus interface	X	5	–	–	2 inputs
Frequency inverter 1 via bus interface	EtherCAT master	–	–	X	5	–

To transfer the EtherCAT process data, the bus interface provides one slot for the bus interface's I/Os and four slots for frequency inverters, which are connected to the bus interface via the system bus. In the configuration software, the relevant modules (I/Os, NORDAC *BASE*, NORDAC *FLEX*, NORDAC *LINK*) can be configured into the slots. The modules are stored in the device description file and cannot be modified. The combination of the modules in the slots must, however, take place depending on the application.

In the default, only FI1 is configured in the respective slot.

3.3.6.1 Process data telegrams

The process data telegram for a frequency inverter contains 12 bytes of frequency inverter data:

Direction of transmission	Transmitted data					
	1st word	2nd word	3rd word	4th word	5th word	6th word
	12 Byte					
To the frequency inverter	Control word	Setpoint 1	Setpoint 2	Setpoint 3	Setpoint 4	Setpoint 5
From the frequency inverter	Status word	Actual value 1	Actual value 2	Actual value 3	Actual value 4	Actual value 5

3.3.7 Parameter data transmission

In the "CAN over EtherCAT" protocol (CoE), transmission of parameter data is only carried out via a single SDO channel. The parameter data of the module and frequency inverter are transferred (read or written).

As the NORD parameter numbers of the frequency inverter (0 to 999) are within a number range of the EtherCAT field bus system, which is already occupied, Getriebebau NORD GmbH & Co. has defined the following parameter number range:

	FI
Start offset	2000h
Number range	2000h-27FFh

NORD parameter numbers must be converted according to the following formula:

Start offset + NORD parameter number = EtherCAT parameter number

- **Example for parameter no. 102** (P102 → 102_{dec} = 66h),

Frequency inverter FI: 2000h + 66h = 2066h

Information

For parameters with arrays, the first value is always on array "1". Array "0" contains the maximum size of the array.

3.3.7.1 EtherCAT parameters (CoE directory)

Index	Array	Object name	Description	Read/Write	Type (value)
1000h	0	Device Type	Device type and functionality	RO	U32
1008h	0	Device Name	Device name	RO	STR
1009h	0	Hardware Version	Hardware configuration level	RO	STR
100Ah	0	Software version	Software version	RO	STR
1018h	REC	Identity Object	General device information	—	U32
	0	Largest Array	Number of elements (=4)	RO	U8
	1	Vendor ID	Manufacturer code (Getriebebau Nord: 00000538h)	RO	U32
	2	Product Code	Device version (product number)	RO	U32
	3	Revision Number	Software version and revision number (2 x 16 bit)	RO	U32
	4	Serial Number	Not supported	RO	U32
1600h	0	Largest Array	Number of elements	RO	U8
1600h	0-4	RxPDO Mapping	Setpoints	RO	U32
1A00h	0	Largest Array	Number of elements	RO	U8
1A00h	0-4	TxPDO Mapping	Actual values	RO	U32
1C00h	0-4	Sync.Manager Com. Type	Shows the assignment and usage of the sync channels	RO	U8
1C10h	0	Sync.Manager Channel 0	Mailbox reception	RO	UCHAR

Index	Array	Object name	Description	Read/Write	Type (value)
1C11h	0	Sync.Manager Channel 1	Mailbox sending	RO	UCHAR
1C12h	5	Sync.Manager Process Data Output	Process data output	RO	U16
1C13h	5	Sync.Manager Process Data Input	Process data input	RO	U16

3.3.7.2 SDO error codes

If an SDO transmission fails, a corresponding error code is produced:

Error code	Description
05030000h	Toggle bit unchanged
05040000h	Timeout SDO message (timeout for the SDO response of the bus interface)
05040001h	SDO command invalid/unknown
05040005h	No memory (Insufficient memory)
06010000h	Illegal access to an object
06010001h	Reading access to write-only parameter
06020002h	Writing access to read-only object
06020000h	Object does not exist in the object dictionary (access to a non-existent parameter)
06040043h	Parameter incompatibility
06060047h	Internal incompatibility in the bus interface
06060000h	Access failed due to hardware error
06070012h	Incorrect data type, parameter too long
06070013h	Incorrect data type, parameter too short
06090011h	Sub-Index of parameter does not exist
06090030h	Parameter value range overflow
06090031h	Parameter value too large
06090032h	Parameter value too small
06090036h	Maximum value smaller than the minimum value
08000000h	General error
08000020h	Data transfer or saving not possible, as there is no communication between the bus interface and the frequency inverter

3.3.8 FoE functionality

The FoE (file transfer over EtherCAT) function enables file transfer to the frequency inverter or bus interface. Only files for the firmware update can be sent to the frequency inverter or bus interface. All other transfers are rejected.

The frequency inverter or bus interface is ideally set to the “Bootstrap” EtherCAT state, and the file transfer is started. A transfer is also possible in the “Safe-Operational” and “Operational” modes. However, the file transfer to the frequency inverter or bus interface will take considerably longer.

An update is always possible in the factory settings. If this is not required, this can be prevented using parameter P853. This setting can be reset via EtherCAT; however new writing is not possible.

For information on the procedure for firmware updates, please refer to Chapter  4.6.2 "Firmware update with EtherCAT".

3.4 EtherNet/IP basics

3.4.1 Characteristics

EtherNet/IP (Ethernet Industrial Protocol) is an open communication protocol for industrial automation systems, which uses the basic technology of Ethernet TCP/IP and the CIP (Common Industrial Protocol) application protocol.

According to the OSI reference model (Open Systems Interconnection Model = Reference model for network protocols as layer architecture), EtherNet/IP consists of an adaptation of the CIP technology in the three upper layers (5...7), and of standard Ethernet in the four lower layers (1...4).

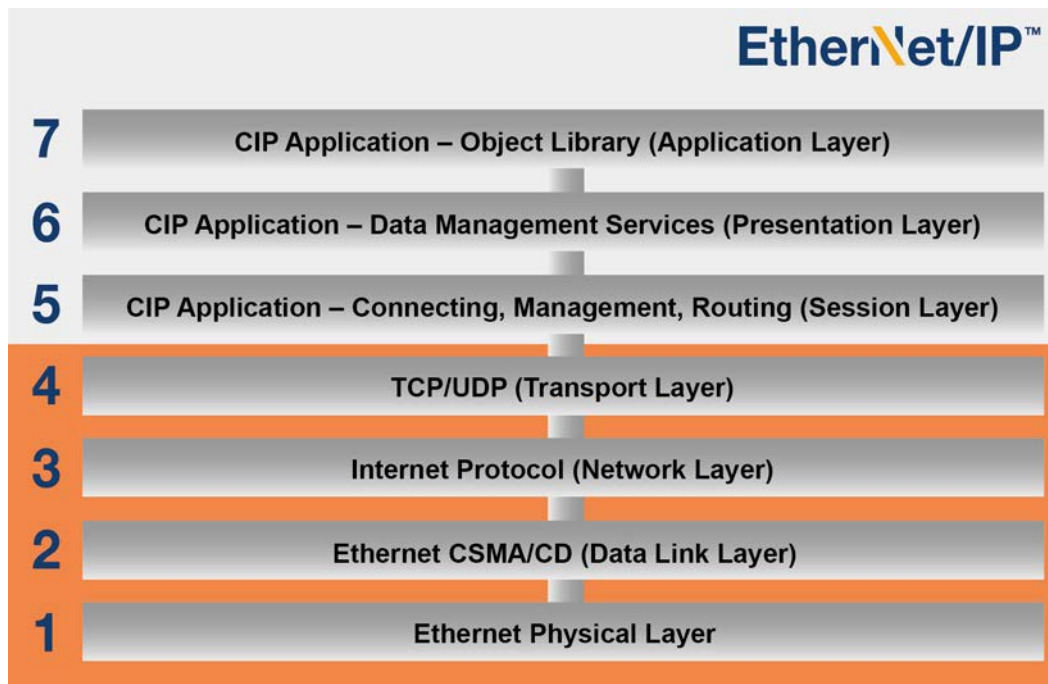

Figure 6: CIP adaptation with EtherNet/IP according to the OSI layer model

Layer	OSI description	EtherNet/IP adaptation
1	Physical layer, defines the hardware, coding, speed etc. of data transfer	Technology according to standard IEEE 802.3: Definition of the physical media, framework format for data communication, CSMA/CD (Carrier Sense Multiple Access/Collision Detection data communication rules = Multiple access with carrier checks and collision detection).
2	Link layer, defines the communication physics (access method in the field bus and data backup).	Technology according to standard IEEE 802.3: Access procedure according to CSMA/CD which regulates the behaviour of devices in the field bus system.
3...4	The allocation layer (Network) takes over the routing of the data packages to the next bus participant; the transport layer (Transport) allocates the data packages to an application.	TCP/IP (Transmission Control Protocol/Internet Protocol) and UDP (User Datagram Protocol)
5...7	CIP application layers (object oriented), define the interface to the application program with the application-orientated commands.	

EtherNet/IP is managed by the association of users and manufacturers, ODVA (Open DeviceNet Vendors Association).

EtherNet/IP® and CIP® are registered trademarks of the ODVA.

EtherNet/IP is an object oriented field bus system according to CIP, which operates with the Producer/Consumer method. In contrast to conventional transmission/reception methods, in which messages are addressed to particular recipients, with the Consumer/Producer method the field bus participants determine whether they are to process a message on the basis of the Connection ID which is contained in the data telegram.

EtherNet/IP devices can be integrated into an EtherNet/IP field bus system without configuration, however they must be provided with a unique IP address.

Performance description

Possible number of bus participants	255
Transfer rate	100 MBit (Switched Ethernet, Full Duplex)
Supported functions	UCMM, DLR
Supported connection types	<ul style="list-style-type: none"> • Explicit Messaging Connection (parameter data) • I/O Connection (process data): 1 Exclusive Owner, 2 Listen Only
Wiring	Standard Ethernet cable CAT 5 or better
Cable length	Max. 100 m between 2 devices

3.4.2 Topology

The following topologies are supported:

- Linear topology
- Star topology
- Ring topology (No external switch required for bus participants with DLR option (Device Level Ring)).

3.4.3 Bus protocol

The data which are to be communicated via the EtherNet/IP field bus are embedded in standard Ethernet frames.

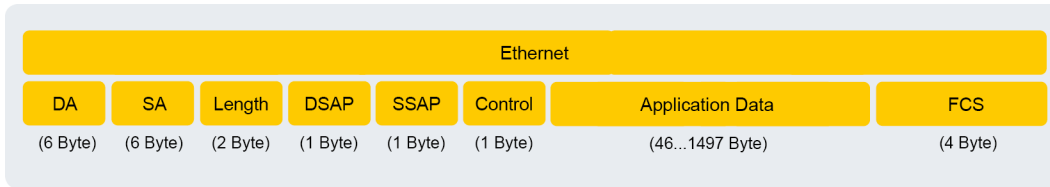

Figure 7: Ethernet telegram (minimum frame length 64 Byte)

Designation	Description
DA	Destination Address = Destination address of the Ethernet frame
SA	Source Address = source address of the Ethernet frame
Length	Information about the length of the application data
DSAP	Destination Service Access Point
SSAP	Source Service Access Point
Control	Type of LLC frame (Logical Link Control Frame)
Application Data	Useful load (min. 46 Byte, max. 1497 Byte)
FCS	Checksum for the Ethernet frame

Data communication (Network Layer and Transport Layer)

A connection between the transmitting and receiving bus participants must be established (via Unconnected Message Manager UCMM) for the exchange of application data. A connection which has been established is used to transmit so-called "Explicit Messages" (data which is necessary for configuration, diagnosis and management) or "I/O Messages" (real time I/O data, also known as "Implicit Messages").

CIP protocol (Application Layer)

The CIP application layer defines the exchange of I/O Messages and Implicit Messages. Communication between two field bus participants is carried out according to a connection-oriented communication model via a point-to-point connection. The data exchange is by means of objects, which are entered in the object index of the field bus device.

In the CIP protocol, each field bus participant receives an object library. CIP objects are subdivided into classes, instances and attributes. A class consists of objects which define the system components of a field bus participant. An instance is a particular object within a class. All instances of a class have the same attributes, but individual attribute values.

See  Section 3.4.5 "Parameter data transmission" for detailed information.

3.4.4 Assembly Object

The process data (without protocol information) are communicated with the aid of the I/O Message Object. Assignment of the relevant setpoints and actual values is performed via the Assembly Object. The following table contains defined configurations (instances).

Instance	Data length	Description	Length
100	12 Byte	per frequency inverter: CTW + SW1 + SW2 + SW3 + SW4 + SW5	Variable
101	12 Byte	per frequency inverter: STW + IW1 + IW2 + IW3 + IW4 + IW5	Variable
110	98 bytes	Bus interface outputs and 4 frequency inverters per frequency inverter: CTW + SW1 + SW2 + SW3 + SW4 + SW5	Variable
111	98 bytes	Bus interface inputs and 4 frequency inverters per frequency inverter: STW + IW1 + IW2 + IW3 + IW4 + IW5	Variable

3.4.5 Parameter data transmission

Access to all parameters of the frequency inverters is via Explicit Messages. A point-to-point connection is established according to the Client/Server principle for the transmission.

The connected frequency inverters are accessed via various classes.

EtherNet/IP Class	Accessed device
100	Module parameter
101	Frequency inverter FI 1
102	Frequency inverter FI 2
103	Frequency inverter FI 3
104	Frequency inverter FI 4

Encoding of frequency inverter parameters to the EtherNet/IP format:

Parameter number in EtherNet/IP format	
Class	 Previous table
Attribute	Parameter number
Instance	Array

EtherNet/IP format in parameter number	
Parameter number	Attribute
Array	Instance

An instance is created depending on the parameter structure.

The following applies to parameter set-dependent parameters without arrays (e.g. parameter **P103**):

Parameter set	Bit 1	Bit 0	Instance
1	0	0	0
2	0	1	1
3	1	0	2
4	1	1	3

The following applies to non-parameter set-dependent parameters with arrays (e.g. **P465**):

Array	...	Bit 3	Bit 2	Bit 1	Bit 0	Instance
[-01]		0	0	0	0	0
[-02]		0	0	0	1	1
[-03]		0	0	1	0	2
[-04]		0	0	1	1	3
[-05]		0	1	0	0	4
...						

The following applies to parameter set-dependent parameters with arrays (e.g. **P400**):

		Array			Parameter set		Instance
Array	Parameter set	...	Bit 3	Bit 2	Bit 1	Bit 0	
[-01]	1		0	0	0	0	0
[-01]	2		0	0	0	1	1
[-01]	3		0	0	1	0	2
[-01]	4		0	0	1	1	3
[-02]	1		0	1	0	0	4
[-02]	2		0	1	0	1	5
...							

Examples:

Device	Parameters	Array	Parameter set
FI 1	P103	—	1

→

Class	Attribute	Instance
101	103	0

3.5 PROFINET IO basics

3.5.1 Characteristics

PROFINET IO is a protocol for communication with peripherals based on the Ethernet standard IEEE 802.3. PROFINET IO is based on PROFIBUS DP and uses Switched-Ethernet technology as the physical communication medium for the rapid communication of I/O data and parameters. PROFINET IO is specified in the standards IEC 61158 and IEC 61784.

In contrast to the PROFIBUS Master-Slave method, PROFINET IO is a Provider-Consumer model, which supports communication relations (CR) between equal field bus participants. In addition to the cyclic exchange of process data, diagnostic data, parameters and alarms can be communicated via the PROFINET IO field bus system.

PROFIBUS® and PROFINET® are registered trademarks of PROFIBUS and PROFINET International (PI).

PROFINET IO bus participants are classified according to their tasks:

Name	PROFINET IO bus participant	Task
IO Controller	Controller (PLC)	Performs the provider function for I/O data communication with bus participants and controls the process. As a provider, the IO controller sends the output data to the IO devices and as a consumer, it processes the input data which is sent from the IO devices.
IO Device	Decentralised field bus device	As a provider, the IO device sends the input data to the ¹⁾ IO controller and as a consumer it processes the output data which is sent from the IO controller.
IO Supervisor	Programming device, HMI or PC	PROFINET IO tool for parameterisation and diagnosis of IO devices, which is for the most part only used temporarily ²⁾ for commissioning and diagnostics.
1) There can also be several IO controllers to which data is sent. 2) IO supervisors can also be permanently installed and used.		

Addressing of PROFINET IO bus participants is carried out via:

- The unique MAC address of the device,
- The unique assigned device name and
- The unique assigned IP address.

For communication between the IO controller and an IO device a so-called “Application Relation” **AR** is established, with which the “Communication Relations” **CR** are specified.

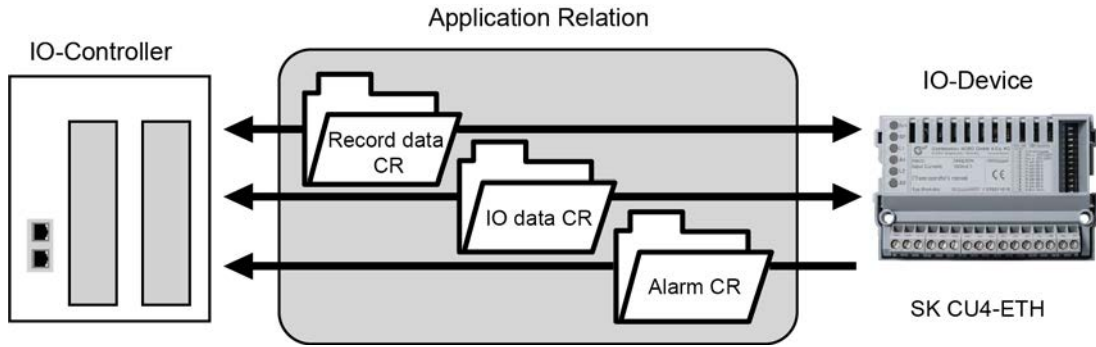

Figure 8: PROFINET IO communication via Application Relation AR

Communication Relation CR	Description
IO data CR	For cyclic communication of process data
Record data CR	For acyclic communication of parameter data
Alarm CR	For alarm messages in real time

Performance description

Standards	IEC 61158, IEC 61784
Possible number of bus participants	Practically unlimited, depending on the number of participants with which the used IO controller can communicate.
Transfer rate	100 MBit (Switched Ethernet, Full Duplex)
Update interval	≥ 5 ms (exchange of process data with the frequency inverter)
Conformance class	B, C
Transmission and reception cable	Auto Crossover, Auto Negotiation, Auto Polarity
Wiring	Standard Ethernet cable CAT 5 or better
Cable length	Max. 100 m between two nodes

3.5.2 Topology

The following topologies are supported:

- Linear topology
- Star topology
- Tree topology
- Ring topology (Media Redundancy Protocol (MRP) required)

3.5.3 Bus protocol

The PROFINET IO process data are embedded in standard Ethernet frames. For communication of process data, a PROFINET IO frame is identified with the label "8892h" and a frame ID in the type field "Ethertype".

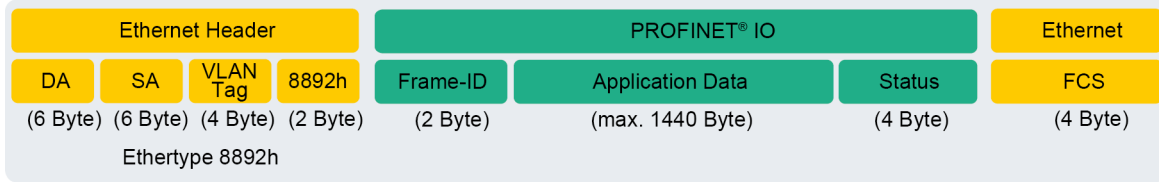

Figure 9: PROFINET IO telegram (communication within a sub-net)

	Designation	Description
Ethernet Header	DA	Destination Address = Destination address of the PROFINET IO frame
	SA	Source Address = Source address of the PROFINET IO frame
	VLAN Tag	Identifier for communicating the priority
	8892h	Ethertype identifier
PROFINET IO	Frame ID	Data identifier for cyclic or acyclic communication
	Status	Status information
Ethernet	FCS	Checksum of the PROFINET IO frame

PROFINET IO is subdivided into various performance classes, the so-called "Conformance Classes" CC-A, CC-B and CC-C.

Conformance Class	Description
CC-A	<ul style="list-style-type: none"> • Cyclic exchange of I/O data with real time characteristics • Acyclic data exchange for reading and writing of parameters and diagnostic data, including the function Identification & Maintenance I&M for reading out device information • Alarm function for signalling device and network faults in three levels (maintenance requirement, urgent maintenance requirement, diagnosis)
CC-B	<ul style="list-style-type: none"> • Cyclic exchange of I/O data with real time characteristics • Acyclic data exchange for reading and writing of parameters and diagnostic data, including the function Identification & Maintenance I&M for reading out device information • Alarm function for signalling device and network faults in three levels (maintenance requirement, urgent maintenance requirement, diagnosis) • Network diagnosis with the Simple Network Management Protocol (SNMP) • Topology detection with the Link Layer Discovery Protocol (LLDP)
CC-C	<ul style="list-style-type: none"> • Cyclic exchange of I/O data with the Isochronous Real Time Protocol • Acyclic data exchange for reading and writing of parameters and diagnostic data, including the function Identification & Maintenance I&M for reading out device information • Alarm function for signalling device and network faults in three levels (maintenance requirement, urgent maintenance requirement, diagnosis) • Network diagnosis with the Simple Network Management Protocol (SNMP) • Topology detection with the Link Layer Discovery Protocol (LLDP) • Reservation of bandwidth: Part of the available communication bandwidth of 100 MBit is exclusively reserved for real time tasks • Synchronisation of the application program clock to the bus cycle

Process data is transferred – cyclically and in real-time – from the IO controller to the IO devices, and vice versa from the IO devices to the process map of the IO controller. As the IO controller transfers without a request, the IO devices are informed during system start-up that they are receiving current data in a certain bus cycle.

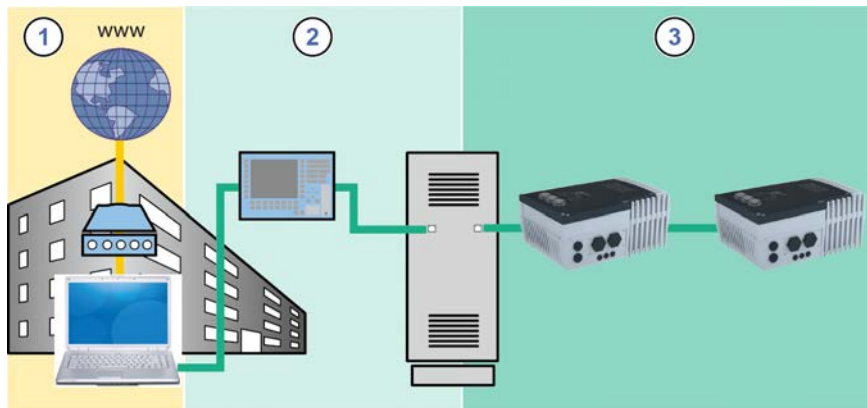

Figure 10: PROFINET IO data cycle times

Item	Description
1	Standard communication (IT services, TCP/IP)
2	Process automation
3	Motion control
TCP/IP	Internet protocol, cycle time less than 100 ms
RT	Real time protocol, cycle time less than 10 ms

PROFINET IO real time communication is divided into the following classes:

RT class	Description
RT_CLASS_1	Unsynchronised real time communication within a sub-network (identical to network ID) Unsynchronised RT communication is the normal form of PROFINET IO data communication and is implemented in all IO field devices. Industrial standard switches can be used in this RT class. Suitable for typical cycle times of 10 ms.
RT_CLASS_2 (IRT Flex)	RT_CLASS_2 frames can be communicated either synchronised or unsynchronised. With synchronised communication the start of a bus cycle is defined for all participants. This defines precisely when a field device may transmit. This is always the start of the bus cycle (clock synchronisation) for all field devices involved in RT_CLASS_2 communication. Combination with RT_Class_1 is possible.
RT_CLASS_3 (IRT or IRT Top)	Synchronised communication within a sub-net. Transmission of process data takes place in a sequence which is specified by the system engineering. This optimised data communication requires considerable planning effort, special hardware and the use of real time switches. Suitable for cycle times of 0.25 ms...1 ms.
RT_CLASS_UDP	Unsynchronised data exchange of UDP data packages between different sub-nets. Suitable for the communication of PROFINET IO data which are not time-critical. This RT communication (Transport Protocol TCP/UDP-ID) can be implemented with all standard network components (e.g. Internet, company Intranet, etc.) Data cycles of 5 ms with 100 Mbit/s can be achieved in Full Duplex mode.

The bus interface has an integrated switch with two ports for setting up a linear topology.

Communication between the NORD drive components is via the NORD system bus. The required communication time is added to the runtime for PROFINET IO communication.

The specific values for the update interval for process data, parameter reading and writing access can be obtained from the data sheet of the respective SK xU4-ETH-... module.

3.5.4 Application data structure

The cyclic exchange of application data between IO controller and frequency inverter is performed via two areas:

- PKW area = Parameter ID Value (parameter level)
- PZD area = Process data (process data level)

Parameter values are read and written via the PKW area. Basically, these are tasks for configuration, monitoring and diagnosis.

The frequency inverter is controlled via the PZD area. This is done by transmission of the control word, the status word and by setpoint and actual values.

An access always consists of request telegram and response telegram. In the request telegram, the application data is transferred from the IO controller to the IO device. In the response telegram, the application data is transferred from the IO device to the IO controller.

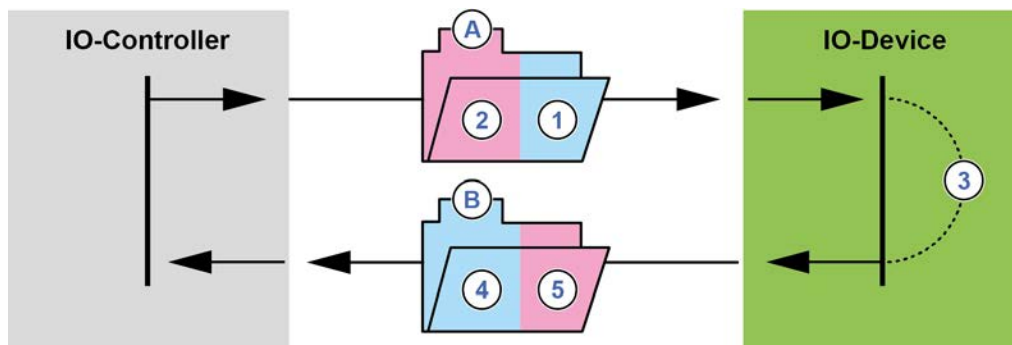

Figure 11: Application area structure – Telegram traffic

Item	Meaning
A	Request telegram
1	Parameter request
2	Control word and setpoints
3	Processing
B	Response telegram
4	Parameter response
5	Status word and actual value

Processing of the process data in the frequency inverter is carried out with high priority, in order to ensure a rapid response to control commands takes place and status changes are transmitted to the IO controller without delay.

Processing of PKW data is carried out with low priority and can take significantly more time.

The cyclic data traffic is carried out via parameter process data objects (PPO) defined in PROFIBUS, with which process data (PZD) as well as parameters (PKW) are transferred from the IO controller to the IO device. NORD frequency inverters can process the PPO types 1, 2, 3, 4 and 6.

Structure of PPO types:

	PKW				PZD					
	PKE	IND	PWE	PWE	PZD1	PZD2	PZD3	PZD4	PZD5	PZD6
					CTW	SW1	SW2	SW3	SW4	SW5
					STW	IW1	IW2	IW3	IW4	IW5
1st word	2nd word	3rd word	4th word	5th word	6th word	7th word	8th word			
PPO 1	x	x	x	x	x	x				
PPO 2	x	x	x	x	x	x	x	x		
					1st word	2nd word	3rd word	4th word	5th word	6th word
PPO 3					x	x				
PPO 4					x	x	x	x		
PPO 6					x	x	x	x	x	x

3.5.5 Transfer of process data

The control word (CTW) and up to 5 setpoints (SW) are transferred from the IO controller to the frequency inverter, and the status word (STW) and up to 5 actual values (IW) are transferred from the frequency inverter to the IO controller as process data.

Addressing of the process data is performed with a slot/index combination. The IO controller reads the slots and subslots of NORD frequency inverters from the device description file (📖 Section 4.2 "Download device description file").

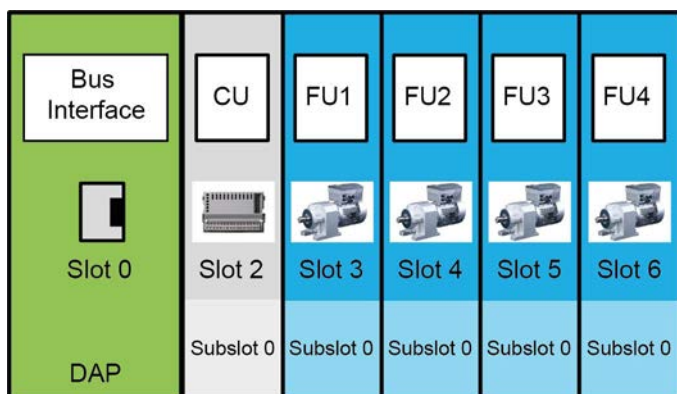

Figure 12: Example – PROFINET IO device model

Designation	Description
DAP	Device Access Point, access point for communication with the Ethernet interface
F11 to F14	Frequency inverter

The length and structure of the process data are determined by the PPO types, which the IO controller reads from the device description file. The PPO types must be assigned to the frequency inverter's slot during the configuration of the IO controller (PLC project). The PPO types are defined in the PROFIBUS profile.

3.5.5.1 Process data telegrams

Getriebebau NORD GmbH & Co. KG uses the PPO types PPO3, PPO4 and PPO6 as process data telegrams for cyclic communication of process data.

PPO3

Transmission direction	Transmitted data (4 bytes)	
	1st word	2nd word
to the frequency inverter	Control word	Setpoint 1
from the frequency inverter	Status word	Actual value 1

PPO4

Transmission direction	Transmitted data (8 bytes)			
	1st word	2nd word	3rd word	4th word
to the frequency inverter	Control word	Setpoint 1	Setpoint 2	Setpoint 3
from the frequency inverter	Status word	Actual value 1	Actual value 2	Actual value 3

PPO6

Transmission direction	Transmitted data (12 bytes)					
	1st word	2nd word	3rd word	4th word	5th word	6th word
to the frequency inverter	Control word	Setpoint 1	Setpoint 2	Setpoint 3	Setpoint 4	Setpoint 5
from the frequency inverter	Status word	Actual value 1	Actual value 2	Actual value 3	Actual value 4	Actual value 5

Getriebebau NORD GmbH & Co. KG uses the PPO types PPO1 and PPO2 for the cyclic exchange of process and parameter data.

PPO1

Transmission direction	Transmitted data (12 bytes)					
	1st word	2nd word	3rd word	4th word	5th word	6th word
to the frequency inverter	AK and PNU	IND	PWE HI	PWE LO	Control word	Setpoint 1
from the frequency inverter	AK and PNU	IND	PWE HI	PWE LO	Status word	Actual value 1

AK Request ID
 IND Parameter index
 PNU Parameter number
 PWE Parameter value

PPO2

Transmission direction	Transmitted data (16 bytes)							
	1st word	2nd word	3rd word	4th word	5th word	6th word	7th word	8th word
to the frequency inverter	AK and PNU	IND	PWE HI	PWE LO	CTW	Setpoint 1	Setpoint 2	Setpoint 3
from the frequency inverter	AK and PNU	IND	PWE HI	PWE LO	STW	Actual value 1	Actual value 2	Actual value 3

AK Request ID
 IND Parameter index
 PNU Parameter number
 PWE Parameter value

3.5.6 Parameter data transmission

Transmission of parameter data is carried out acyclically. In case of acyclic communication, the assignment of the parameter requests takes place via the specification of the data set (see Section 3.5.6.2 "Data sets for acyclic parameter requests"). The slots are relevant for cyclic parameter requests.

The following are transferred:

- higher-level parameter data of the bus interface
- parameter data of the F11... frequency inverters

Using the PKW area (see 3.5.4 "Application data structure") parameter processing can also be carried out in cyclic data traffic. The EtherNet/IP-Busmaster formulates a request and the frequency inverter formulates the suitable response. The PKW area is only used for the communication with the PPO types 1 and 2.

The PKW area basically consists of

- a **parameter ID (PKE)**, in which the type of request (write, read etc.) and the relevant parameter are specified,
- an **index (IND)**, with which the individual parameter sets or arrays are addressed,
- the **parameter value (PWE)**, which contains the value read or to be written.

Field ¹⁾		Data size	Explanation
PKE	Parameter ID (request ID AK and parameter number PNU)	2 Byte	Parameter of bus interface or frequency inverter. Parameter number plus "1000" The request ID is attached to the parameter number (upper nibble ²⁾).
IND	Parameter index	2 Byte	Parameter array
PWE	Parameter value	4 Byte	New setting value

1) Description of fields in the following sections.

2) 1 nibble = 4 bit

A parameter request must be repeated until the frequency inverter responds with the relevant response telegram.

Information

Max. 100,000 permissible write cycles

If parameter changes are made (request by the EtherNet/IP-Busmaster via the PKW channel), the maximum number of permissible write cycles to the frequency inverter's EEPROM (100,000 cycles) must not be exceeded. That means, continuous cyclic writing must be prevented. This is also valid for other parameterisation approaches and the acyclic data transfer.

For certain applications it is sufficient if the values are only stored in the frequency inverter's RAM. The corresponding setting can be made by selecting the appropriate AK or via the parameter **P560 Save on EEPROM**.

3.5.6.1 Procedure of the acyclic parameter data exchange (records)

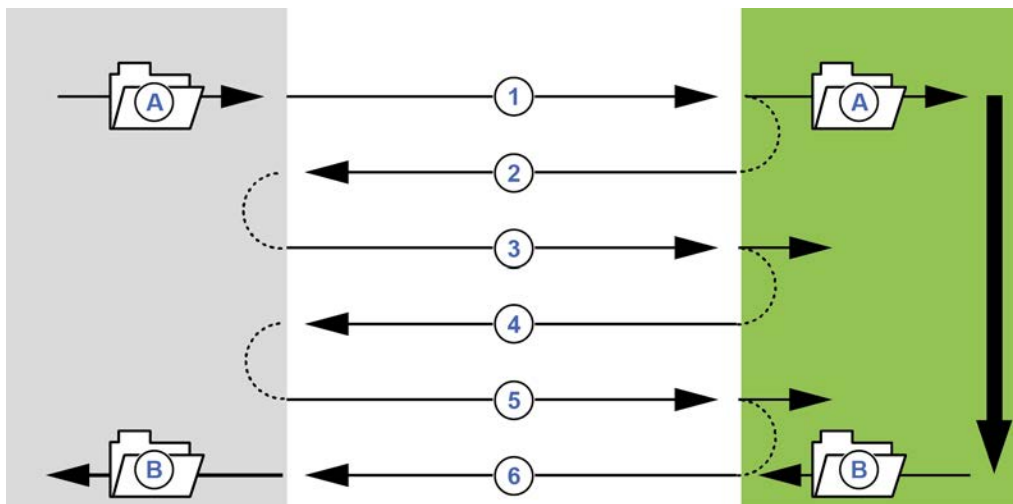

Figure 13: Procedure of the acyclic PROFINET IO parameter data exchange

Item	Meaning	Comment
A	Parameter request	
B	Parameter response	
1	Write Request (with data)	"Write Request" submits the parameter request to the IO device.
2	Write Response (without data)	"Write Response" confirms to the IO controller the receipt of the message.
3	Read Request (without data)	With "Read Request", the IO controller requests a response from the IO device.
4	Read Response (-) (without data)	The IO device responds with "Read Response (-)" as long as the processing has not yet been completed.
5	Read Request (without data)	With "Read Request", the IO controller requests a response from the IO device.
6	Read Response (+) (with data)	After processing the parameter request, the IO device responds with "Read Response (+)". The parameter request is completed.

During the transfer of parameter requests, the positive response from the IO device to the IO controller may be delayed by one or more communication cycles. Therefore, the IO controller must repeat the request until the respective response has been received from the IO device.

3.5.6.2 Data sets for acyclic parameter requests

Parameter requests are transferred as data sets. The data sets are generally transferred to the bus interface. In the system bus, the number of the data set determines the recipient of the parameter request:

- Data set 100** Request to the bus interface (Bus interface parameter)
- Data set 101** Request to frequency inverter 1 (parameter of FI1)
- Data set 102** Request to frequency inverter 2 (parameter of FI2)
- ...
- Data set 104** Request to frequency inverter 4 (parameter of FI4)

3.5.6.3 Format of parameter requests

3.5.6.4 Parameter ID PKE

The request or the response, and the related parameter have been encrypted in the parameter ID PKE.

PKE															IND	PWE1	PWE2	
15	14	13	12	11	10	9	8	7	6	5	4	3	2	1	0			
AK				SPM	PNU													

The parameter ID PKE is always a 16-bit value.

- PNU** Bits 0 to 10 contain the number of the required parameter or the number of the current parameter in the response telegram from the frequency inverter.
The value 1000 (dec) must be added to the parameter number.
Parameter numbers  Manual for the respective frequency inverter
- SPM** Bit 11 is the toggle bit for instant messages. This function is **not** supported.
- AK** Bits 12 to 15 contain the request and response ID.

Request ID and response ID AK

Up to 15 parameter requests can be transmitted by the EtherNet/IP-Busmaster.

The right-hand column of the following table lists the corresponding ID of a positive response. The ID of a positive response depends on the request ID.

Meaning of requests IDs

Request ID	Function	Response ID (positive)
0	No request	0
1	Request parameter value	1 or 2
2	Change parameter value (word)	1
3	Change parameter value (double word)	2
4	Reserved	—
5	Reserved	—
6	Request parameter value (array)	4 or 5
7	Change parameter value (array, word)	4
8	Change parameter value (array, double word)	5
9	Request the number of array elements	6
10	Reserved	—
11	Change parameter value (array, double word) without writing to the EEPROM	5
12	Change parameter value (array, word) without writing to the EEPROM	4
13	Change parameter value (double word) without writing to the EEPROM	2
14	Change parameter value (word) without writing to the EEPROM	1

Meaning of response IDs

Response ID	Meaning
0	No response
1	Transmit parameter value (word)
2	Transmit parameter value (double word)
4	Transmit parameter value (array, word)
5	Transmit parameter value (array, double word)
6	Transmit the number of array elements
7	Request cannot be executed (with error number in PWE2)

For all request IDs, the ID of a negative response is always the value “7” (Request cannot be executed). In case of a negative response, an error number or code is also listed in the parameter value PWE2 of the frequency inverter’s response.

Meaning of error messages in parameter value PWE2

Error message	Meaning
0	Invalid parameter number
1	Parameter value cannot be changed
2	Lower or upper value limit exceeded
3	Incorrect subindex
4	No array
5	Invalid data type
6	Reset only (only 0 may be written)
7	Description element cannot be changed
9	Description data does not exist
201	Invalid request element in the last request received
202	Internal response ID cannot be mapped

3.5.6.5 Parameter index IND

Structure and function of the parameter index depend on the type of the parameter to be transmitted.

PKE	IND															PWE1	PWE2	
	15	14	13	12	11	10	9	8	7	6	5	4	3	2	1			0
							P1...P4		No information (all "0")									
	Arrays 1...64						P1...P4											
	Arrays 1...256																	

For **parameter set-dependent parameters**, the parameter set can be selected via Bit 8 and Bit 9 of the index (Parameter set 1: 00b, Parameter set 2: 01b, etc.).

For **parameter set-dependent array parameters**, the parameter set can be selected via Bit 8 and Bit 9, and the array index via Bit 10 to Bit 15 of the index (Array index 1: 000000b, Array index 2: 000001b, etc.).

For **non-parameter set-dependent array parameters**, the array index can be selected via Bit 8 to Bit 15 of the index (Array index 1: 00000000b, Array index 2: 00000001b, etc.).

Examples for address generation in case of parameter set-dependent array parameters

Array element						Parameter set									
15	14	13	12	11	10	9	8	7	6	5	4	3	2	1	0
0	0	0	1	0	1	0	1	No information (all "0")							
5 (0001 01b)						2 (01b)									

Array element						Parameter set									
15	14	13	12	11	10	9	8	7	6	5	4	3	2	1	0
0	1	0	1	0	1	1	1	No information (all "0")							
21 (0101 01b)						4 (11b)									

For parameter and array structure  Manual of used frequency inverter.

3.5.6.6 Parameter value PWE

Parameter values are transmitted depending on the respective parameter properties as word (16 bit) or double word (32 bit). In case of signed values, attention must be paid to the fact that the file type (integer or double integer) match the parameter's file type. If, for example, a 16-bit variable with a negative value is written to a 32-bit frequency inverter parameter, this value will be interpreted as a positive value. In this case, perform a data type conversion prior to the data transfer.

The parameter value is transmitted as an integer value.

For parameters with resolution "0.1" or "0.01", the parameter value must be multiplied by the reciprocal value of the parameter resolution.

Example

You want to set an acceleration time of 99.99 seconds.

$$PWE = P102 * (1 / \text{parameter resolution } P102) = 99.99 * (1 / 0.01) = 9999 = 270Fh$$

The value "9999" (270Fh) must be transmitted.

3.5.7 Examples of data record transfer

Read parameter P717 Current speed

Data set 101 (F11) is used.

Sample telegram

Field	Data size	Byte	Date			Explanation	
Request ID AK	4 bits	1 (upper nibble)	1h			Request parameter value (read)	
Instant message SPM	1 bit	1 (lower nibble)		0h		Instant message	
Parameter number PNU	11 bits	1 (lower nibble) and 2		6h	Bh	5h	Parameter number P717 (717+1000) = 6B5h
			16B5h				
Parameter index	2 bytes	3	00h			Parameter array	
		4	00h				
Parameter value	4 bytes	5	00h			Setting value not set for read request	
		6	00h				
		7	00h				
		8	00h				

Sample code (SIEMENS TIA Portal V17)	Explanation
<pre>„WRREC_DB“ (REQ := #bStart, ID :=“SK-CU4-ETH~Head“ INDEX :=101 LEN :=8 DONE :=#bEnd BUSY :=#bBusy_WRREC, ERROR :=#bError_WRREC, STATUS :=wStatus_WRREC, RECORD :="Data".write) ;</pre>	<p>→ Write request</p> <p>→ TIA system constant of the bus module (device name + addition “~Head”)</p> <p>→ Data set 101 (F11)</p> <p>→ Length: 8 bytes</p> <p>→ Data: PKE = 244Eh, IND = 0100h, PWE1 = 0000h, PWE2 = 00FAh</p>
<pre>“RDREC_DB” (REQ :=#bDone, ID :=“SK-CU4-ETH~Head“ INDEX :=101 MLEN :=8 VALID =>#bValid, BUSY =>#bBusy_RDREC, ERROR =>#bError_RDREC, STATUS =>#dwStatus_RDREC, LEN =>#uiLEN, RECORD :="Data".read) ;</pre>	<p>→ Read response</p> <p>→ TIS system constant of the module (device name + addition “~Head”)</p> <p>→ Data set 101 (F11)0</p> <p>→ Length: 8 bytes</p> <p>→ Response: PKE = 16B5h, IND = 0000h, PWE1 = 0000h, PWE2 = 03FCh</p>
<p>Read value: P717 = 1020 (03FCh)</p>	

Write parameter P102 Acceleration time, Index 1

Data set 101 (FI1) is used.

Sample telegram

Field	Data size	Byte	Date			Explanation
Request ID AK	4 bits	1 (upper nibble)	2h			Request parameter value (read)
Instant message SPM	1 bit	1 (lower nibble)		0h		Instant message
Parameter number PNU	11 bits	1 (lower nibble) and 2		4h	4h Eh	Parameter number P102 (102+1000) = 44Eh
			244Eh			
Parameter index	2 bytes	3	01h			Parameter array
		4	00h			
Parameter value	4 bytes	5	00h			The time "2.5 s" (250 = FAh) is to be set.
		6	00h			
		7	00h			
		8	FAh			

Sample code (Siemens TIA Portal V17)	Explanation
<pre> "WRREC_DB" (REQ :=#bStart, ID :="SK-CU4-ETH~HEAD", INDEX :=-101, LEN :=8, DONE :=#bDone, BUSY :=#bBusy_WRREC, ERROR :=#bError_WRREC, STATUS :=#dwStatus_WRREC, RECORD :="Data".write); </pre>	Write request TIA system constant of the bus module (device name + addition "~HEAD") Data set 101 (FI1) Length: 8 bytes Data: PKE = 244Eh, IND = 0100h, PWE1 = 0000h, PWE = 00FAh
<pre> "WRREC_DB" (REQ :=#bDone, ID :="SK-CU4-ETH~HEAD", INDEX :=101 MLEN :=8, VALID :=#bValid, BUSY :=#bBusy_RDREC, ERROR :=#bError_RDREC, STATUS :=#dwStatus_RDREC, LEN :=#uiLEN RECORD :="Data".read); </pre>	Read response TIA system constant of the bus module (device name + addition "~HEAD") Data set 101 (FI1) Length: 8 bytes Response: KPE = 144Eh, IND = 0100h, PWE1 = 0000h, PWE2 = 0000h

3.5.7.1 Telegram structure for parameterisation via PPO1 or PPO2

The parameter **P102 Acceleration time** is to be set to the value 2.5 s in parameter set 3 (only the PKW channel is considered). As the acceleration time has a parameter resolution of 0.01 s, the parameter value 250 (FAh) must be transmitted.

Procedure

1. Define request ID (7 = "Change parameter value (array, word)").
2. Select parameter (P102 + 1000 = 44Eh).
3. Select parameter set 3 (IND = 02h).
4. Set parameter value (250 = FAh).
5. Check response telegram (positive with 4 in the AK [top nibble of the PKE]).

Request telegram from IO controller

Word	1		2		3		4	
Byte	1	2	3	4	5	6	7	8
Name	PKE	PKE	IND	IND	PWE	PWE	PWE	PWE
Value	74h	4Eh	02h	00h	00h	00h	00h	FAh

Response telegram from frequency inverter (after complete request processing)

Word	1		2		3		4	
Byte	1	2	3	4	5	6	7	8
Name	PKE	PKE	IND	IND	PWE	PWE	PWE	PWE
Value	44h	4Eh	02h	00h	00h	00h	00h	FAh

4 Initial setup

4.1 Setting the field bus protocol

The frequency inverter can communicate with various field bus systems via the field bus interface. The field bus protocol is set with parameter **P899** or via DIP switches. The following values are possible:

- 0: No change
- 1: PROFINET IO
- 2: EtherCAT
- 3: EtherNet/IP

After successful completion of the change, the parameter resets to the setting 0.

The change between the bus systems only takes place if there is no communication via the Ethernet interface. This includes the field bus communication as well as the NORDCON communication via Ethernet.

The currently active field bus protocol can be read with parameter **P870**.



4.2 Download device description file

After connecting the frequency inverter, please download the device description file from our website www.nord.com directly via the link [NORDAC Options](#).

The device description file contains a description of the device characteristics of the module.

4.3 Setting up EtherCAT

The bus interface must be set up in order to commission the field bus system. This includes the following work:

Type of work	Description
Configure the control project	 4.2 "Download device description file"
Assign the bus address	 4.3.1 "Automatic device detection"
Make the required parameter settings	 5.2.1 "EtherCAT standard parameters"

First of all, the EtherCAT master must be configured in the PLC project. For configuration, use an automation or control software that is suitable for real-time execution and diagnosis, e.g. "TwinCAT" from Beckhoff Automation GmbH & Co. KG.

4.3.1 Automatic device detection

With EtherCAT, you can address the bus components via direct access to the system as well as without direct access to the system.

- If the system is physically available, install the device description file and start a bus scan. The EtherCAT master uses the parameters "Software-Version", "Vendor-ID" and "Product Code" to determine the sequence of the EtherCAT slaves and stores them in the configuration software.
- If the system is not available, you can also do the configuration in the software offline. Configure the EtherCAT slaves manually in the later physical sequence of the EtherCAT slaves.

Information

In delivery state, the device description file is set to a connected frequency inverter (F11).

If several frequency inverters are to be connected to the bus interface, they must be set in the configuration software after the installation of the device description file.



This basically creates the configuration. However, if the configuration is changed during runtime, the EtherCAT slaves must also receive a unique address. This is the Second Address, which is either set via parameter **P850** or via the bus interface's DIP switches, and configured in the EtherCAT master. However, attention must be paid to the fact that there are two procedures for the Second Address: "Configured Station Alias" and "Explicit Device Identification". The "Configured Station Alias" is set in parameter **P850 [-01]** and "Explicit Device Identification" is set in **P850 [-02]** or via DIP switch. The DIP switch has higher priority. As soon as a DIP address larger than 0 has been set, **P850 [-02]** will be ignored. The DIP address is not reflected in **P850 [-02]**.

Information

Bus participants without Hot Connect function must always be physically arranged at the start of the field bus system. No bus participant without this function may be located in the EtherCAT line after a bus participant with the Hot Connect function.

4.4 Setting up the EtherNet/IP

The bus interface must be set up in order to commission the field bus system. This includes the following work:

Type of work	Description
Configure the control project	 4.2 "Download device description file"
Assign the bus address	 4.4.2 "EtherNet/IP field bus address"
Make the required parameter settings	 5.2.2 "EtherNet/IP standard parameters"

The bus master (PLC project of the bus master) must first be configured for communication with the module. The configuration must be produced with a software system for EtherNet/IP field bus systems.

4.4.1 Automatic device detection

In order for the frequency inverter to be automatically detected by the bus master during the bus scan, the following settings must be made in the configuration software after installation of the device description file:

- Enter the module into the EtherNet/IP field bus system
- Specify the characteristics (Assembly, IP address) of the bus interface.

4.4.2 EtherNet/IP field bus address

In order for the module to be detected by the bus master, an IP address must be assigned to the inverter. The settings can be made by two different methods

1. Setting the IP address via DHCP or BOOTP mode

Set Parameter **P856 Addressing Mode** to "DHCP" or "BOOTP" ( section 5.2.2 "EtherNet/IP standard parameters") and restart the module (turn voltage supply off and on again). Only after a DHCP or BOOTP server belonging to the module has successfully assigned an IP address (see parameter **P875** and **P876**) can the frequency inverter in the EtherNet/IP configuration software be set up.

2. Set the IP address via parameters in the NORDCON software as described below.

Information

It is only possible to change the IP address if NORDCON is directly connected to the RJ12 connection of the bus interface (SK TU4-ETH-...) or of the frequency inverter (for SK CU4-ETH(-C)).

It is not possible to change the IP address with NORDCON via TCP.

Information

On setting parameter **P865** to the value "0" the IP address from the settings in parameters **P850 IP address**, **P851 IP Sub-net Mask** and **P852 IP Gateway** is adopted.

Setting the IP address via parameters in the NORDCON software (Item 2.)

The following parameters must be set in the NORDCON software:

- **P856 Addressing Mode**
- **P850 IP Address**
- **P851 IP Subnetmask**

- **P852 IP Gateway** (if the gateway function is configured)

Requirement



- The EtherNet/IP field bus system has been installed and commissioned according to the manufacturer's instructions.
- A NORDCON computer is available ( [BU 0000](#)).

Procedure

1. Open the entry for the module in the tree directory of the NORDCON software, call up the standard parameter **P856 Addressing Mode**, select the setting "0" and save this with "**ENTER**".
2. Call up the standard parameter **P850 IP Address**, enter the IP address and save with "**ENTER**".
3. Call up the standard parameter **P851 IP Sub-net Mask**, enter the IP sub-net mask and save with "**ENTER**".
4. Call up the standard parameter **P852 IP Gateway**, enter the IP address for the gateway function and save this with "**ENTER**".
 - The parameter settings are adopted immediately if no communication via Ethernet takes place.
 - The parameter changes are only displayed in P875 and P876 if there is an active connection.

4.5 Setting up PROFINET IO

The bus interface must be set up in order to commission the field bus system. This includes the following work:

Type of work	Description
Configure the control project	 4.2 "Download device description file"
Assign the bus address	 3.5.3 "Bus protocol"
Make the required parameter settings	 5.2.3 "PROFINET IO standard parameters"

The bus master (PLC project of the IO controller) must first be configured for communication with the module. The configuration must be produced with a software system for PROFINET IO field bus systems (e.g. "TIA Portal" from Siemens AG).

For the integration of NORD frequency inverters into the Siemens AG SIMATIC Manager, Getriebebau NORD GmbH & Co. KG provides TIA standard modules, which can be used for PROFINET IO ( [BU 0950](#)).

The following parameters are relevant for establishing communication via PROFINET IO:

- **P850 IP Address**
- **P851 IP Subnetmask**
- **P854 Device Name**
- **P852 IP Gateway** (if the gateway function is configured)

Only the assignment of the device name (**P854**) by the commissioner is necessary. Assignment of the IP address data (**P850, P851, P852**) is normally carried out automatically by the IO controller.

Requirement

- The PROFINET IO field bus system has been installed and commissioned according to the manufacturer's instructions.
- Access to the parameters is possible (a SK PAR-3H, SK CSX-3H, SK TIE5-BT-STICK control module or a NORDCON computer are available ( [BU 0000](#))).

Procedure

1. Assign a device name, an IP address and a sub-net mask and if necessary activate the gateway function in the PROFINET IO configuration software for the bus master.
2. Call up parameter **P854 Device Name** of the module, enter the device name and save.

Information

In order for the module to be detected when the IO controller is started up, the device name which is entered here must conform with the device name which is assigned in the PLC project.

Observe the following conventions when entering the device name:

- The device name may have a maximum of 127 characters. Lower case letters a...z, numbers 0...9, hyphens "-" and full stops "." are permissible.
- A character string between two hyphens or two full stops may only have a maximum length of 63 characters.
- The device name must not contain any special characters (umlauts, brackets, slashes and underscores etc.) or spaces.
- The device name must not begin or end with a hyphen.
- The device name must not begin or end with a number.
- The device name must not have the format "n.n.n.n" or start with the character sequence "port-*nnn*" (*n* = 0...9).

In addition, the IP address data can be parameterised as follows:

3. Enter parameter **P850 IP Address**, enter the IP address and save.

Information

It is only possible to change the IP address if NORDCON is directly connected to the RJ12 connection of the bus interface (SK TU4-ETH-...) or of the frequency inverter (for SK CU4-ETH(-C)).

It is not possible to change the IP address with NORDCON via TCP.

Information

If the IP address of the module has been configured in the PLC project, this is automatically assigned to the module when the IO controller is started up. In this case, the currently set IP address can be determined via parameter **P875**.

If the IP address which is entered does not conform with the IP subnetmask which is entered in parameter **P851** the IP subnetmask is corrected automatically.

4. Access parameter **P851 IP Subnetmask**, enter the IP sub-net mask and save.

Information

If the IP sub-net mask has been configured in the PLC project, this is automatically assigned to the module when the IO controller is started up. In this case, the currently set IP subnet mask can be determined via parameter **P876**.

The IP sub-net mask is only saved after a value is entered in the array element [-04].

If the IP sub-net mask does not conform with the IP address which is entered in **P850** the entry is not saved.

5. Call up parameter **P852 IP Gateway**, enter the IP address of the gateway and save.

 **Information**

If the IP address for the gateway function has been configured in the PLC project, this is automatically assigned to the module when the IO controller is started up. In this case, the present IP address can be determined via parameter **P877**.

4.6 Firmware update

4.6.1 Basic information on the firmware update

If it is necessary to update the frequency inverter or bus interface firmware, you will receive all relevant information and data from NORD Drivesystems GmbH & Co. KG (NORD). The following descriptions serve as orientation for the update process and assume that you coordinated the planned updates with your contact person at NORD accordingly.

An update is always possible in the factory settings. If this is not required, this can be prevented using parameter P853.

It is assumed that the bus interface and frequency inverter firmware updates are carried out via Ethernet. A bus interface firmware update via the diagnostic port (RJ12) is generally not possible.

4.6.2 Firmware update with EtherCAT

You can carry out a firmware update via the FoE EtherCAT function.

For the FoE file download, the following inputs are **always** required:

- File name: **update**
- Password: **0x300**

The transfer of the update file and the adoption of the new operating system (initialisation) can take several minutes.

NOTICE

Device damage due to interference

Interference of the update and initialisation process (e.g. cancellation of the process, interruption of the cable connection, power supply or similar) can irreversibly damage the firmware of the respective device.

- Do not switch off the PC.
- Do not switch off the device during the update and initialisation process.
- Do not remove any cable connections.
- Refrain from carrying out other work on the PC until the update is completed.

Requirement

- The EtherCAT field bus system has been installed and commissioned according to the manufacturer's instructions.
- The file for the firmware update is available.

Procedure

The following explains the individual steps using the TwinCAT 3 software from Beckhoff Automation GmbH & Co. KG as an example.

1. Open the configuration dialogue for EtherCAT.

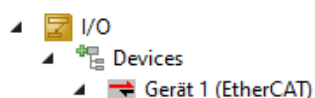

2. Select the "Online" tab.
3. Select the desired frequency inverter in the "Online" tab (click on the left mouse button).

For multiple selection: Hold down the "Ctrl" key.

No	Addr	Name
1	1001	Klemme 2 (EK11110)
2	1002	Box 2 (SK300P_ADV_PMSM)
3	1003	Box 3 (SK300P_ADV_PMSM)
4	1004	Box 4 (SK300P_ADV_PMSM)

4. In the selection made in step 3, click on the right mouse button. In the submenu that opens, select "Request 'BOOTSTRAP' State".
5. In the selection made in step 3, click on the right mouse button. In the submenu that opens, select "Firmware Update".
6. Select the desired update file in the file window that opens.

Note: You may have to set the correct file type in the selection window to make the update file visible.

7. Change the file name or the entry "string" to "**update**".
8. Enter the password "**0x300**" and start the transfer with "OK".
 - The data transfer takes several minutes.
 - The transfer progress can be viewed in the status bar.
 - The data transfer is complete when the word "Download" is no longer displayed in the status bar.

Note: The frequency inverters remain in "Bootstrap" mode.

NOTICE

Abort the download process

The start of the initialisation process (step "9") interrupts communication on the network. For devices for which the download has not yet been completed, this leads to the download being cancelled and to incomplete data on the frequency inverters concerned. The firmware of the device in question may be irreparably damaged as a result.

- Wait until the download process of all relevant frequency inverters in the network is completed, before switching to the initialisation process (step "9").

9. In the selection made in step 3, click on the right mouse button. In the submenu that opens, select "Request 'INI' State". This starts the initialisation process, i.e. the firmware update, for all selected frequency inverters at the same time.
 - The initialisation phase takes several minutes.
 - The diagnostic LEDs for the device status flash red/green during the initialisation.
 - Initialisation is complete when the "red/green" flashing changes to "green" flashing.

Red flashing indicates an active error in the device.

Information

In case of the initialisation process does not start as described above, trigger it directly on the frequency inverter as follows:

- Switch off the control voltage supply or disconnect the frequency inverter completely from the mains.
- Observe the "Waiting period between 2 x "Mains on"" (see "Technical data" of the frequency inverter).
- Switch on the power supply again.

10. The update process is complete. The device can now be used with the updated firmware.

Note: If the display in the user interface of TwinCAT does not update itself, restart the configuration (blue button with gearwheel).

4.6.3 Firmware update with EtherNet/IP or PROFINET IO

You can carry out a firmware update with the NORDCON software via TCP.

The transfer of the update file and the adoption of the new operating system (initialisation) can take several minutes.

NOTICE

Device damage due to interference

Interference of the update and initialisation process (e.g. cancellation of the process, interruption of the cable connection, power supply or similar) can irreversibly damage the firmware of the respective device.

- Do not switch off the PC.
- Do not switch off the device during the update and initialisation process.
- Do not remove any cable connections.
- Refrain from carrying out other work on the PC until the update is completed.

Requirement

- The field bus system (PROFINET IO or EtherNet/IP) has been installed and commissioned according to the manufacturer's instructions.
- A PC with the installed NORDCON software is integrated into the device network and has a valid IP address.
- The file for the firmware update is available in the NORDCON software.

Procedure

1. In the NORDCON software, under "Device /Communication type", select "Ethernet".
2. If necessary, adjust settings under "Extras / Communication settings" to be able to perform a bus scan. Enter the range of IP addresses and save the settings with "Apply".
3. Start a bus scan under "Device / Bus scan" or with the key combination "Ctrl+F5".
 - Connection to the connected devices will be established.
4. In the structure tree, right-click on "Ethernet" and select "Update firmware".
 - A new "Firmware update" window will open.
5. Select the "Import" button in the "Firmware update" window to load the required firmware file in the following file selection window.



- All frequency inverters that are compatible with the loaded firmware file will then be listed.
6. In the list, select the frequency inverters onto which the new firmware file should be installed and select “Upload”.
 - A warning will appear. Carefully read it and confirm with the “I accept” button.
 - The upload of the firmware file starts. The progress of the operation will be displayed in the window.
 - After successful upload, the “Install” button will be active.
 7. To start the installation of the new firmware on the chosen devices, select “Install”.
 - The diagnostic LEDs for the device status alternately flash red/green during the update process.
 - The update process is complete when the “red/green” flashing changes to “green” flashing.

Red flashing indicates an active error in the device.
 - If the installation of the new firmware was successful, the message "Firmware update completed successfully" appears in the program window “Firmware update” as status of the selected device.
 8. After successful installation, close the “Firmware update” window.
 9. Restart the device.
 10. The update process is complete. The device can now be used with the updated firmware.

For further information on the operation of the NORDCON software, please refer to the online help or to the corresponding manual  [BU 0000](#).

4.7 Specify data format for process data

For the cyclic transfer of process data for the frequency inverter, the data format must be specified in the configuration project. Detailed information about the process data can be found in the following sections:

- EtherCAT  Section 3.3.6 "Transfer of process data"
- EtherNet/IP  Section 3.4.5 "Parameter data transmission"
- PROFINET IO  Section 3.5.5 "Transfer of process data"

5 Parameter

The frequency inverter parameters are communicated as words (16*bits/word). The exception to this are position values (POSICON), which can be communicated as double words (32 bits).

For field bus operation, several parameters must be set on the frequency inverter and on the bus interface.

The parameters can be set via

- SK PAR-3H, SK CSX-3H or SK TIE5-BT-STICK control module,
- NORDCON software ([BU 0000](#)) or
- the operator's PLC project.

The parameters are classified as

- NORD-specific and field bus-specific standard parameters and
- NORD-specific and field bus-specific information parameters:

The basic settings of the frequency inverter and of the bus interface can be made via NORD standard parameters.

Field-bus specific settings of the bus interface can be made via the field bus-specific standard parameters.

NORD information parameters are used to display current and archived error messages, as well as actual operating states.

Field bus-specific information parameters are used to display statuses and settings which are specific for the field bus.

The following sections contain a detailed description of the parameters which are relevant for field bus communication.

5.1 NORD standard parameters

P151	TimeOut External Bus												
Setting range	0...32767 ms												
Factory setting	{ 0 }												
Bus interface	SK CU4-ETH , SK TU4-ETH												
Description	<p>If an invalid control word (Bit 10 = 0) is sent via the external bus, a valid control word (Bit 10 = 1) must be submitted during the time set in P151. Failure to do this results in the bus interface reporting fault E220/220.1 "Bus Time Out".</p> <p>This function simultaneously monitors all frequency inverters connected to the bus interface. To trigger the fault, an invalid control word must be sent to all connected frequency inverters during the set time. As soon as a frequency inverter receives a valid control word, the communication via the external bus is considered to be faultless.</p>												
Setting values	0 = Monitoring control word off												
Note	<p>You can find an overview of the device's reaction to typical operator errors in connection with certain settings of the monitoring parameters here:  6 "Error monitoring and error messages".</p> <p>Parameter P513 on the frequency inverter determines the behaviour of the drive system in case of an error message by the bus interface. Further detailed information can be found in the manual of the respective frequency inverter.</p>												
P152	Factory setting												
Setting range	0...1												
Factory setting	{ 0 }												
Bus interface	SK CU4-ETH , SK TU4-ETH												
Description	Reset the present parameter settings of the bus interface to the factory setting.												
Setting values	<table border="1"> <thead> <tr> <th>Value</th> <th>Meaning</th> <th>Remarks</th> </tr> </thead> <tbody> <tr> <td>0</td> <td>No change</td> <td>Current parameter settings will not be changed</td> </tr> <tr> <td>1</td> <td>Factory setting Load</td> <td>All bus interface parameters will be reset to the factory setting. The setting of parameter P152 then automatically changes back to { 0 }.</td> </tr> </tbody> </table>				Value	Meaning	Remarks	0	No change	Current parameter settings will not be changed	1	Factory setting Load	All bus interface parameters will be reset to the factory setting. The setting of parameter P152 then automatically changes back to { 0 }.
Value	Meaning	Remarks											
0	No change	Current parameter settings will not be changed											
1	Factory setting Load	All bus interface parameters will be reset to the factory setting. The setting of parameter P152 then automatically changes back to { 0 }.											

P153	Min.SystembusCycle	
Setting range	0...250 ms	
Arrays	[-01] = TxSDO device	Minimal distance between two parameter queries Transfer direction Bus interface → frequency inverter
	[-02] = TxPDO device	Minimal cycle time process data (control word + setpoint) Transfer direction Bus interface → frequency inverter
	[-03] = TxPDO Inverter	Minimal cycle time process data (status word + setpoint) Transfer direction Frequency inverter → bus interface
Factory setting	{ [-01] = 10 } { [-02] = 5 } { [-03] = 10 }	
Bus interface	SK CU4-ETH , SK TU4-ETH	
Description	<p>Parameter requests and process data are transmitted on the system bus based on events, i.e. changes are applied immediately. The minimum cycle time between two changes is set to prevent the bus load from becoming too high in case of changes in rapid succession (e.g. during the transfer of the current position). If the process data remain unchanged the process data will be transferred with a maximum cycle time of 250 ms. The minimal system bus cycle time for the process data in the transfer direction FU -> bus interface is a function in the frequency inverter and will be configured according to the parameter settings each time the bus interface in the frequency inverter is switched on.</p>	

P154	Access TU IOs		
Setting range	0...5		
Arrays	[-01] = Access to the inputs [-02] = Access to the outputs		
Factory setting	{ [-01] = 0 } { [-02] = 0 }		
Bus interface	SK CU4-ETH , SK TU4-ETH		
Description	Assign write and read rights of each connected frequency inverter to 2 inputs and 2 outputs of the bus interface. This is carried out via the following parameters of the frequency inverter:		
	Input 1	Evaluation via P480 Funct. BusIO In Bits , Array [-11]	
	Input 2	Evaluation via P480 Funct. BusIO In Bits , Array [-12]	
	Output 1	Evaluation via P481 Funct-BusIO Out Bits , Array [-09]	
	Output 2	Evaluation via P481 Funct-BusIO Out Bits , Array [-10]	
Note	The SK CU4-ETH bus interface has no outputs. When using this bus interface, array [-02] has no function.		
Setting values	Value	Meaning	Comments
			Array [-01] (inputs) Array [-02] (outputs)
	0	No access	No influence by the frequency inverter (FI).
	1	Broadcast	All connected frequency inverters read the inputs No function.
	2	FI 1	FI 1 reads the inputs. FI 1 writes to the outputs.
	3	FI 2	FI 2 reads the inputs. FI 2 writes to the outputs.
	4	FI 3	FI 3 reads the inputs. FI 3 writes to the outputs.
	5	FI 4	FI 4 reads the inputs. FI 4 writes to the outputs.
P853	TCP Ethernet rights		
Setting range	0...3		
Array	[-01] = Permissions for parameter and setpoints for TCP access [-02] = Permissions for firmware updates		
Factory setting	{ [-01] = 0 }		{ [-02] = 1 }
Description	This parameter is only relevant for access from NORDCON via Ethernet. It defines the access rights for parameters, setpoints and firmware updates for this TCP access. Reading the parameters is independent from the setting in P853 and is therefore always possible.		
Note	Writing only possible via USS.		
Setting values	Value [-01]	Meaning	
	0	Read parameter, control off	
	1	Read and write parameter, control off	
	2	Read parameter, control on	
	3	Read and control parameter, control on	
	Value [-02]	Meaning	
	0	FW update prohibited	
	1	FW update permitted	

P895	FW-Update Management		
Setting range	[-01] = 0...2	[-02] = Will be set automatically	
Array	[-01]= FW-Update Management	[-02]= FW update waiting time	
Factory setting	{ [-01] = 0 }	{ [-02] = dependent on the update file }	
Description	P895 [-02] shows the FW update wait time for an Update file in s after loading this update file.		
Setting values	0 =	No change	
	1 =	Start Update	Manuel triggering of the update, e.g., via the NORDCON software
	2 =	Delete update file	In case a wrong update file was uploaded, the update file can be deleted with this function.
P899	Change bus protocol		
Setting range	0...4		
Factory setting	{ 0 }		
Description	Enter the relevant value to change the field bus protocol. After successful completion of the change, the parameter resets to the setting 0. In order to change the field bus protocol, there must be no communication via Ethernet, or control is not via Ethernet (P509/P510).		
Setting values	Value	Meaning	
	0	No action	
	1	PROFINET IO	
	2	EtherCAT	
	3	EtherNet/IP	
	4	Reserved	

5.2 Field bus-specific standard parameters

5.2.1 EtherCAT standard parameters

P850	Second Address
Setting range	0...32767
Array	[-01] = Configured Station Alias [-02] = Explicit Device Identification
Factory setting	[-01] = { 0 }, [-02] = { 0 }
Description	Setting of the “Second Address” for the Hot Connect function. In the Hot Connect function, the frequency inverter can be reached via the “Configured Station Alias” or “Explicit Device Identification” parameter.
Note	The address which is set is only adopted by the frequency inverter after a “POWER ON”.

5.2.2 EtherNet/IP standard parameters

P850	IP Address			
Setting range	0...255			
Array	[-01] = IP-High	[-03] = IP		
	[-02] = IP	[-04] = IP Lo		
Factory setting	{ [-01] = 192 }	{ [-02] = 168 }	{ [-03] = 1 }	{ [-04] = 100 }
Description	Set the 4 byte IP address of the module. The parameter is taken over immediately. However, the parameter is not taken over if an active connection to the controls exist.			
Note	<ul style="list-style-type: none"> In order for the set IP address to be adopted, parameter P856 Addressing Mode must be set to the value "0". The IP address which is set at present can be determined via the parameter P875. 			

P851	IP Subnetmask			
Setting range	0...255			
Array	[-01] = IP Sub 1	[-02] = IP Sub 2	[-03] = IP Sub 3	[-04] = IP Sub 4
Factory setting	{ [-01] = 255 }	{ [-02] = 255 }	{ [-03] = 255 }	{ [-04] = 0 }
Description	Set the 4 byte IP subnetmask. The parameter is taken over immediately. However, the parameter is not taken over if an active connection to the controls exist.			
Note	<ul style="list-style-type: none"> In order for the set IP subnetmask to be adopted, parameter P856 Addressing Mode must be set to the value "0". The address of the IP subnetmask which is set can be determined via the parameter P876. 			

P852	IP Gateway															
Setting range	0...255															
Array	[-01] = IP High		[-03] = IP													
	[-02] = IP		[-04] = IP Lo													
Factory setting	{ [-01] = 0 }	{ [-02] = 0 }	{ [-03] = 0 }	{ [-04] = 0 }												
Description	Set the 4 byte IP address for the gateway. The parameter is taken over immediately. However, the parameter is not taken over if an active connection to the controls exist.															
Note	<ul style="list-style-type: none"> In order for the set IP address of the gateway to be adopted, parameter P856 Addressing Mode must be set to the value "0". The IP-Address of the Gateway can be determined via the parameter P877. 															
P856	Addressing mode															
Setting range	0...2															
Factory setting	{ 1 }															
Description	The setting of this parameter determines the method by which the IP address is set. After setting, restart the module (switch the power supply off and on again) so that the parameter setting is read in.															
Note	<ul style="list-style-type: none"> If this parameter is set to the value "0", the IP address is adopted from the settings of parameters P850, P851 and P852. 															
Setting values	<table border="1"> <thead> <tr> <th>Value</th> <th>Meaning</th> <th></th> </tr> </thead> <tbody> <tr> <td>0</td> <td>Fixed</td> <td>Set parameters P850, P851, P852</td> </tr> <tr> <td>1</td> <td>BOOTP</td> <td>Set the IP configuration in the EtherNet/IP configuration software in BOOTP mode</td> </tr> <tr> <td>2</td> <td>DHCP</td> <td>Set the IP configuration in the EtherNet/IP configuration software via DHCP</td> </tr> </tbody> </table>				Value	Meaning		0	Fixed	Set parameters P850, P851, P852	1	BOOTP	Set the IP configuration in the EtherNet/IP configuration software in BOOTP mode	2	DHCP	Set the IP configuration in the EtherNet/IP configuration software via DHCP
Value	Meaning															
0	Fixed	Set parameters P850, P851, P852														
1	BOOTP	Set the IP configuration in the EtherNet/IP configuration software in BOOTP mode														
2	DHCP	Set the IP configuration in the EtherNet/IP configuration software via DHCP														

5.2.3 PROFINET IO standard parameters

P850	IP Address			
Setting range	0...255			
Array	[-01] = IP-High		[-03] = IP	
	[-02] = IP		[-04] = IP Lo	
Factory setting	{ [-01] = 192 }	{ [-02] = 168 }	{ [-03] = 20 }	{ [-04] = 200 }
Description	Set the 4-byte IP address of the module.			
Note	If the IP address of the module has been configured in the PLC project, this is automatically assigned to the module when the IO controller is started up. This parameter is then set to "0". In this case, the currently set IP address can be determined via parameter P875 .			
P851	IP Subnetmask			
Setting range	0...255			
Array	[-01] = IP Sub 1	[-02] = IP Sub 2	[-03] = IP Sub 3	[-04] = IP Sub 4
Factory setting	{ [-01] = 255 }	{ [-02] = 255 }	{ [-03] = 255 }	{ [-04] = 0 }
Description	Set the 4-byte IP subnet mask.			
Note	If the IP subnet mask has been configured in the PLC project, this is automatically assigned when the IO controller is started up. This parameter is then set to "0". In this case, the currently set IP subnet mask can be determined via parameter P876 .			
P852	IP Gateway			
Setting range	0...255			
Array	[-01] = IP High		[-03] = IP	
	[-02] = IP		[-04] = IP Lo	
Factory setting	{ [-01] = 0 }	{ [-02] = 0 }	{ [-03] = 0 }	{ [-04] = 0 }
Description	Set the 4-byte IP address for the gateway.			
Note	If the IP address of the gateway has been configured in the PLC project, this is automatically assigned to the module when the IO controller is started up. This parameter is then set to "0". In this case, the currently set IP address can be determined via parameter P877 .			

P854	Device name			
Setting range	0...122 (ASCII)			
Factory setting	{ 0 }			
Description	Enter the device name for the module in the field bus system.			
Note	<p>In order for the module to be detected when the IO controller is started up, the device name which is entered here must conform with the device name which is assigned in the PLC project.</p> <p>Observe the following conventions when entering the device name:</p> <ul style="list-style-type: none"> • The device name may have a maximum of 240 characters. Lower case letters a...z, numbers 0...9, hyphens "-" and full stops "." are permissible. • A character string between two hyphens or two full stops may only have a maximum length of 63 characters. • The device name must not contain any special characters (umlauts, brackets, slashes and underscores etc.) or spaces. • The device name must not begin or end with a hyphen. • The device name must not begin or end with a number. • The device name must not have the format "n.n.n.n" or start with the character sequence "port-<i>nnn</i>" (<i>n</i> = 0...9). 			

5.3 NORD information parameters

P170	Actual error
Setting range	0...9999
Arrays	[-01] = Current fault bus interface [-02] = Last fault bus interface [-03] = Current extended fault bus interface [-04] = Last extended fault bus interface
Bus interface	SK CU4-ETH , SK TU4-ETH
Description	Display of the current fault present. For a list of possible error messages, please refer to  Chapter 6 "Error monitoring and error messages".
Note	The error message is reset when the supply voltage is switched off.

P171	Software-Version
Display range	0.0...9999.9
Arrays	[-01] = Software version [-02] = Software revision [-03] = Special version [-04] = Application software version [-05] = Application software revision [-06] = Application software special version [-07] = Stack Version 1 [-08] = Stack Version 2 [-09] = Update file version
Bus interface	SK CU4-ETH , SK TU4-ETH
Description	Display of the contained software version and revision number of the bus interface. Array [-03] displays possible special versions (0 = Standard version).

P172	Configuration	
Display range	0 ... 512	
Bus interface	SK CU4-ETH , SK TU4-ETH	
Description	Display of bus interface identifier.	
Display values	Value	Meaning
	0	CU4/PNT Bus interface SK CU4-ETH with PROFINET
	256	CU4/ECT Bus interface , SK TU4-ETH with EtherCAT
	512	CU4/EIP Bus interface , SK TU4-ETH with EtherNet/IP

P174	State of digital in.		
Display range	0 ... 3 (00 ... 11b)		
Bus interface	SK CU4-ETH , SK TU4-ETH		
Description	Display of the current switching state of the digital bus interface inputs		
Display values	Bit	Meaning	
	0	Input 1 (DIN1) of the bus interface	
	1	Input 2 (DIN2) of the bus interface	
P178	Ambient temperature		
Display range	-150...150 °C		
Bus interface	SK CU4-ETH		
Description	Display of the ambient temperature inside the related frequency inverter.		
Note	<p>If a temperature of +100 °C is exceeded in the bus interface, an error message is issued in the bus interface (📖 Error message 2203, Section). This error message is transferred to the frequency inverters that are connected to the bus interface via the system bus. As a result, these frequency inverters are shifted to the error state (📖 Error message 10.1 of the frequency inverter). Furthermore, in SK CU4-ETH, Bit 5 in parameter P872 “<i>Bus state</i>” is set to “High”.</p> <p>After the bus interface has reached a temperature below 100 °C again, the error in the connected frequency inverters can be reset.</p>		
P190	Status Dip-switches		
Display range	0...4095		
Bus interface	SK CU4-ETH , SK TU4-ETH		
Description	Display of the current settings for DIP switches 2 to 12 at the bus interface. Configuration of the DIP switches, 📖 Technical information/data sheet of the bus interface.		
Note	DIP switch 1:	Serves as termination resistor for the NORD system bus and is displayed as “0”	
	DIP switches 2 to 9:	With EtherCAT: Second Address With EtherNet/IP: last byte of the IP address With PROFINET: without function	
	DIP switch 10:	Serves to switch the TCP tunnel, 📖 Technical information/data sheet of the bus interface	
	DIP switches 11 to 12:	Serve to switch the bus system, 📖 Technical information/data sheet of the bus interface.	

P870	Actual bus protocol												
Display range	0 ... 4												
Description	Displays the currently set bus protocol												
Display values	<table border="1"> <thead> <tr> <th>Value</th> <th>Meaning</th> </tr> </thead> <tbody> <tr> <td>0</td> <td>No bus system active</td> </tr> <tr> <td>1</td> <td>PROFINET IO</td> </tr> <tr> <td>2</td> <td>EtherCAT</td> </tr> <tr> <td>3</td> <td>EtherNet/IP</td> </tr> <tr> <td>4</td> <td>Reserved</td> </tr> </tbody> </table>	Value	Meaning	0	No bus system active	1	PROFINET IO	2	EtherCAT	3	EtherNet/IP	4	Reserved
Value	Meaning												
0	No bus system active												
1	PROFINET IO												
2	EtherCAT												
3	EtherNet/IP												
4	Reserved												

P872	Bus state																										
Display range	0...FFFFh																										
Description	Displays the operating state of the bus interface.																										
Display values	<table border="1"> <thead> <tr> <th>Bit</th> <th>Meaning</th> </tr> </thead> <tbody> <tr> <td>0</td> <td>Module ready for operation</td> </tr> <tr> <td>1</td> <td>Cyclic PZD communication</td> </tr> <tr> <td>2</td> <td>Timeout field bus</td> </tr> <tr> <td>3</td> <td>Timeout P151</td> </tr> <tr> <td>4</td> <td>netX not accessible</td> </tr> <tr> <td>5</td> <td>netX in error state</td> </tr> <tr> <td>6</td> <td>System bus "Bus Warning"</td> </tr> <tr> <td>7</td> <td>System bus "Bus Off"</td> </tr> <tr> <td>8</td> <td>State FI1</td> </tr> <tr> <td>9</td> <td>State FI2</td> </tr> <tr> <td>10</td> <td>State FI3</td> </tr> <tr> <td>11</td> <td>State FI4</td> </tr> </tbody> </table>	Bit	Meaning	0	Module ready for operation	1	Cyclic PZD communication	2	Timeout field bus	3	Timeout P151	4	netX not accessible	5	netX in error state	6	System bus "Bus Warning"	7	System bus "Bus Off"	8	State FI1	9	State FI2	10	State FI3	11	State FI4
Bit	Meaning																										
0	Module ready for operation																										
1	Cyclic PZD communication																										
2	Timeout field bus																										
3	Timeout P151																										
4	netX not accessible																										
5	netX in error state																										
6	System bus "Bus Warning"																										
7	System bus "Bus Off"																										
8	State FI1																										
9	State FI2																										
10	State FI3																										
11	State FI4																										

P873	PZD bus in																									
Display range	0...FFFFh																									
Array	<table border="1"> <tbody> <tr> <td>[-01]</td> <td>Output fieldbus unit</td> <td></td> <td></td> <td></td> </tr> <tr> <td>[-02]</td> <td>Control word</td> <td>[-03]...[-07]</td> <td>Setpoints 1 to 5</td> <td>to inv 1</td> </tr> <tr> <td>[-08]</td> <td>Control word</td> <td>[-09]...[-13]</td> <td>Setpoints 1 to 5</td> <td>to inv 2</td> </tr> <tr> <td>[-14]</td> <td>Control word</td> <td>[-15]...[-19]</td> <td>Setpoints 1 to 5</td> <td>to inv 3</td> </tr> <tr> <td>[-20]</td> <td>Control word</td> <td>[-21]...[-25]</td> <td>Setpoints 1 to 5</td> <td>to inv 4</td> </tr> </tbody> </table>	[-01]	Output fieldbus unit				[-02]	Control word	[-03]...[-07]	Setpoints 1 to 5	to inv 1	[-08]	Control word	[-09]...[-13]	Setpoints 1 to 5	to inv 2	[-14]	Control word	[-15]...[-19]	Setpoints 1 to 5	to inv 3	[-20]	Control word	[-21]...[-25]	Setpoints 1 to 5	to inv 4
[-01]	Output fieldbus unit																									
[-02]	Control word	[-03]...[-07]	Setpoints 1 to 5	to inv 1																						
[-08]	Control word	[-09]...[-13]	Setpoints 1 to 5	to inv 2																						
[-14]	Control word	[-15]...[-19]	Setpoints 1 to 5	to inv 3																						
[-20]	Control word	[-21]...[-25]	Setpoints 1 to 5	to inv 4																						
Description	Display of data received from the bus master.																									

P874	PZD bus out																									
Display range	0...FFFFh																									
Array	<table border="1"> <tbody> <tr> <td>[-01]</td> <td>Inputs Bus ext unit</td> <td></td> <td></td> <td></td> </tr> <tr> <td>[-02]</td> <td>Status word</td> <td>[-03]...[-07]</td> <td>Actual values 1 to 5</td> <td>from inv 1</td> </tr> <tr> <td>[-08]</td> <td>Status word</td> <td>[-09]...[-13]</td> <td>Actual values 1 to 5</td> <td>from inv 2</td> </tr> <tr> <td>[-14]</td> <td>Status word</td> <td>[-15]...[-19]</td> <td>Actual values 1 to 5</td> <td>from inv 3</td> </tr> <tr> <td>[-20]</td> <td>Status word</td> <td>[-21]...[-25]</td> <td>Actual values 1 to 5</td> <td>from inv 4</td> </tr> </tbody> </table>	[-01]	Inputs Bus ext unit				[-02]	Status word	[-03]...[-07]	Actual values 1 to 5	from inv 1	[-08]	Status word	[-09]...[-13]	Actual values 1 to 5	from inv 2	[-14]	Status word	[-15]...[-19]	Actual values 1 to 5	from inv 3	[-20]	Status word	[-21]...[-25]	Actual values 1 to 5	from inv 4
[-01]	Inputs Bus ext unit																									
[-02]	Status word	[-03]...[-07]	Actual values 1 to 5	from inv 1																						
[-08]	Status word	[-09]...[-13]	Actual values 1 to 5	from inv 2																						
[-14]	Status word	[-15]...[-19]	Actual values 1 to 5	from inv 3																						
[-20]	Status word	[-21]...[-25]	Actual values 1 to 5	from inv 4																						
Description	Display of data sent from the frequency inverter to the bus master.																									

5.4 Field bus-specific information parameters

5.4.1 EtherNet/IP information parameters

P875	Actual IP address			
Display range	0...255			
Array	[-01]...[-04]			
Description	Displays the present IP address of the bus interface if only one connection is active.			
P876	Present IP sub-net mask			
Display range	0...255			
Array	[-01]...[-04]			
Description	Displays the present sub-net IP address if only one connection is active.			
P878	MAC Address			
Display range	0...FFh			
Array	[-01]...[-03] = Manufacturer ID (Getriebebau NORD GmbH & Co. KG "F0:5F:5A") [-04]...[-06] = Free address range (for Getriebebau NORD GmbH & Co. KG)			
Description	Display of the unique MAC address of the bus interface			
P879	Active assembly			
Display range	0...255			
Array	[-01] = Assembly number for setpoints [-02] = Assembly number for actual values			
Description	Display of the currently assigned assembly object			

5.4.2 PROFINET IO information parameters

P875	Actual IP address			
Display range	0...255			
Array	[-01]...[-04]			
Description	Displays the present IP address of the bus interface if only one connection is active.			
Note	The IP address which is displayed here may deviate from the IP address which is set in parameter P850 (in case of addressing by the IO controller).			
P876	Present IP sub-net mask			
Display range	0...255			
Array	[-01]...[-04]			
Description	Displays the present sub-net IP address if only one connection is active.			
Note	The sub-net mask which is displayed here may deviate from the sub-net mask which is set in parameter P851 (in case of addressing by the IO controller).			
P877	Present IP gateway			
Display range	0...255			
Array	[-01]...[-04]			
Description	Display of the currently set IP address for the gateway (Parameter P852).			
P878	MAC Address			
Display range	0...FFh			
Array	[-01]...[-03] = Manufacturer ID (Getriebebau NORD GmbH & Co. KG "F0:5F:5A") [-04]...[-06] = Free address range (for Getriebebau NORD GmbH & Co. KG)			
Description	Display of the unique MAC address of the bus interface			

P879	PPO-Type																									
Display range	0...255																									
Array	[-01]	Slot 0 (DAP)		[-07]	Slot 6 (FI4)																					
	[-02]	Slot 1 (SAFE)		[-08]	Slot 7 (Reserved)																					
	[-03]	Slot 2 (Bus interface)		[-09]	Slot 8 (Reserved)																					
	[-04]	Slot 3 (FI1)		[-10]	Slot 9 (Reserved)																					
	[-05]	Slot 4 (FI2)		[-11]	Slot 10 (Reserved)																					
	[-06]	Slot 5 (FI3)																								
Description	Display of the currently assigned PPO type.																									
Note	The PPO type is assigned via the PROFINET IO configuration software.																									
Display values	<table border="1"> <thead> <tr> <th>Value</th> <th>Meaning</th> </tr> </thead> <tbody> <tr> <td>0</td> <td>Not available</td> </tr> <tr> <td>3</td> <td>Empty slot</td> </tr> <tr> <td>5</td> <td>Dig-IO</td> </tr> <tr> <td>6</td> <td>PPO3</td> </tr> <tr> <td>7</td> <td>PPO4</td> </tr> <tr> <td>8</td> <td>PPO6</td> </tr> <tr> <td>9</td> <td>PPO1</td> </tr> <tr> <td>10</td> <td>PPO2</td> </tr> <tr> <td>11</td> <td>Dig-IN</td> </tr> <tr> <td>64</td> <td>Module ID DAP of bus interface</td> </tr> </tbody> </table>				Value	Meaning	0	Not available	3	Empty slot	5	Dig-IO	6	PPO3	7	PPO4	8	PPO6	9	PPO1	10	PPO2	11	Dig-IN	64	Module ID DAP of bus interface
Value	Meaning																									
0	Not available																									
3	Empty slot																									
5	Dig-IO																									
6	PPO3																									
7	PPO4																									
8	PPO6																									
9	PPO1																									
10	PPO2																									
11	Dig-IN																									
64	Module ID DAP of bus interface																									

5.5 Frequency inverter parameter settings

After addressing the bus interface, the additional parameters of the frequency inverter must be set as listed below.

A detailed description of the parameters can be found in the manual for the frequency inverter.

Additional parameters

The following table contains a list of additional parameters which are relevant for the bus interface.

No.	Parameter name	Recommended setting	Comment
P509	Source control word	"3" = System bus	Further frequency inverters "3" = System bus
P510	Source Setpoints	"0" = Auto	Further frequency inverters "3" = System bus or "0" = Auto
P513	Telegram time-out	Off	
P514	CAN bus baud rate	"5" = 250 kbaud*	
P515	CAN bus address (Array [-01])	32	System bus address, further frequency inverters 34, 36, 38 ... 46
P543	Bus actual value Arrays [-01] to [-05]	Depending on the function: Setting necessary according to the required functions	Refer to the frequency inverter manual
P546	Func. bus-setpoint Arrays [-01] to [-05]	Depending on the function: Setting necessary according to the required functions	Refer to the frequency inverter manual

6 Error monitoring and error messages

The module is equipped with monitoring functions and generates error messages in case of deviations from the normal operating state.

Error messages which occur in relation to the field bus interface are displayed with parameter **P170 [-01...-04]**. With this the actual and the past extended error can be displayed.

Error code	Explanation
0080	Parameter loss EEPROM
0084	Database version incorrect (internal EEPROM error)
0087	Original and mirror different (internal EEPROM error)
0100	Telegram timeout / CAN Bus Off / CAN initialisation problem
0110	Customer unit (frequency inverter type cannot be determined)
0910	Update failed
0911	Update file corrupt / ID not found
0912	Update timeout / connection to PC failed
0913	Update file type - Update is not possible because P853[-01]=0.
2000	Switching the bus system is not possible since the condition is not met
2001	EtherNet/IP Duplicate Node
2200	Bus timeout, condition set by PLC
2201	Bus timeout, condition set by bus module
2202	Network error, e.g. Ethernet connection interrupted, previous participant in the network has no supply voltage
2203	Module overtemperature
2990	Collection system error

7 Additional information

7.1 Topology overview

Depending on the field bus protocol which is used, an Industrial Ethernet can be set up in various ways. Bus-specific special features or prerequisites are described in  Section 3 "Basics".

7.1.1 Linear topology

Linear topology connects field bus participants which are equipped with integrated switches. An HMI can be optionally integrated.

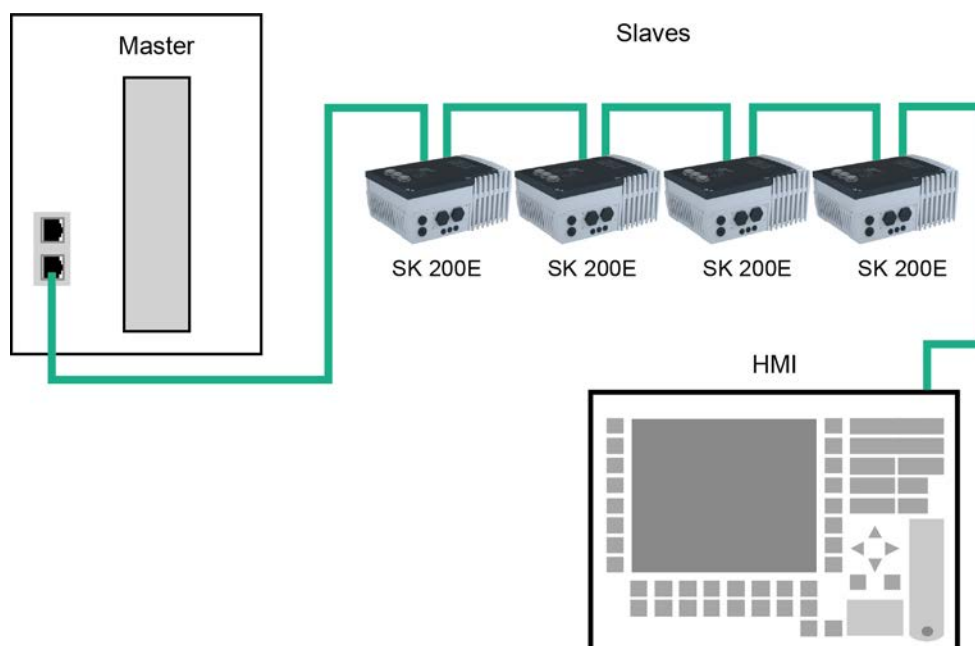

Figure 14: Linear topology (example)

- Benefits:** Requires little cable material, can be extended at the end of the line with little effort.
- Disadvantages:** If the line is interrupted (device failure or defective cable), the downstream field bus participants can no longer be accessed.

7.1.2 Star topology

The star topology requires a central switch (in the control cabinet). An HMI can be optionally integrated.

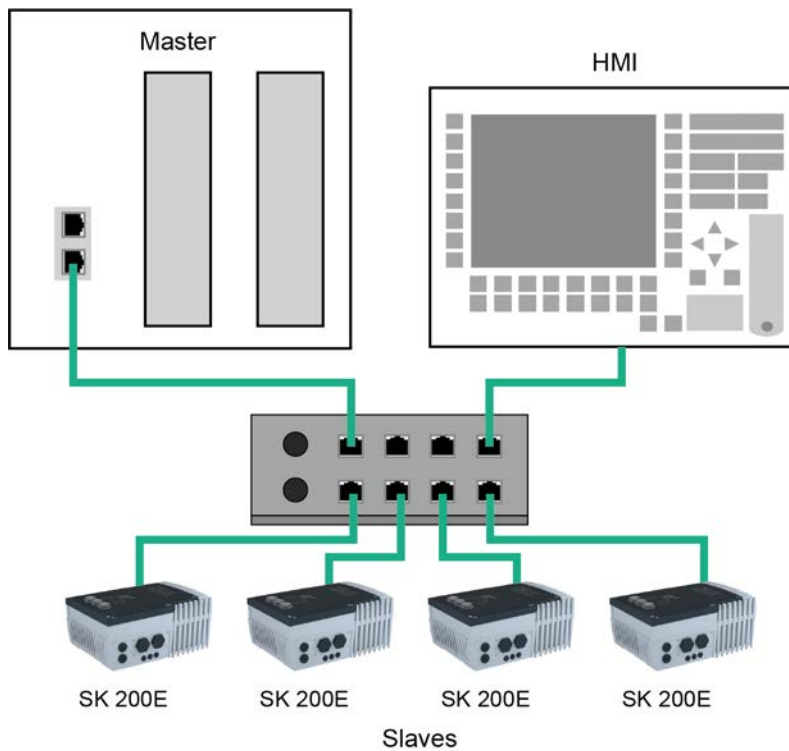

Figure 15: Star topology (example)

- Benefits:** A device failure has no effect on the other bus participants, can be extended with little effort, simple troubleshooting.
- Disadvantages:** Operation of the network is not possible in case of problems with the switch.

7.1.3 Ring topology

With a ring topology, one line is closed to form a ring for media redundancy. An HMI can be optionally integrated.

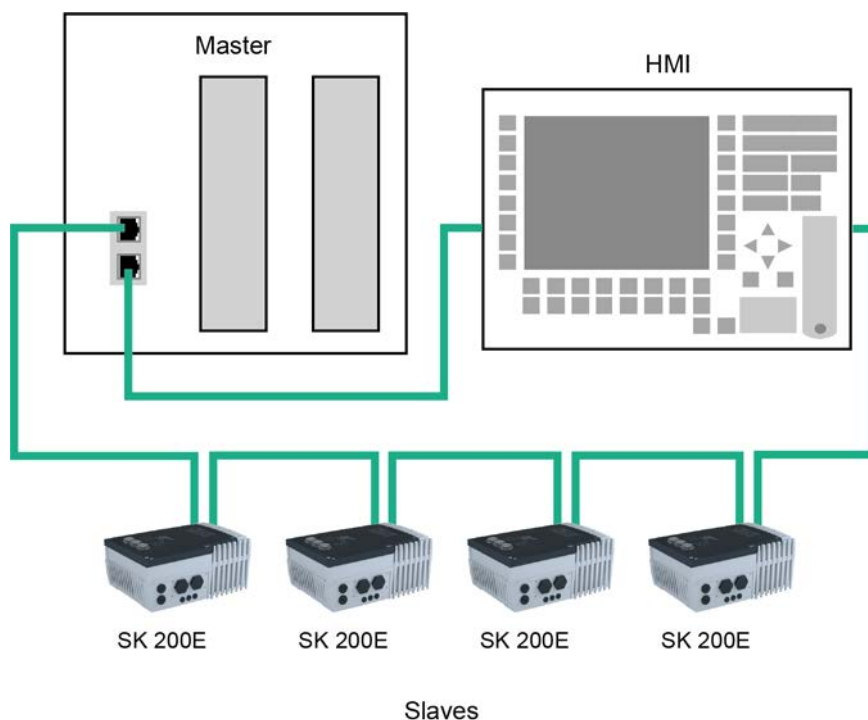

Figure 16: Ring topology (example)

- Benefits:** Communication continues even if one cable is defective.
- Disadvantages:** High load states result in bottlenecks.

7.1.4 Tree topology

In a tree topology, linear and star topologies can be mixed. An HMI can be optionally integrated.

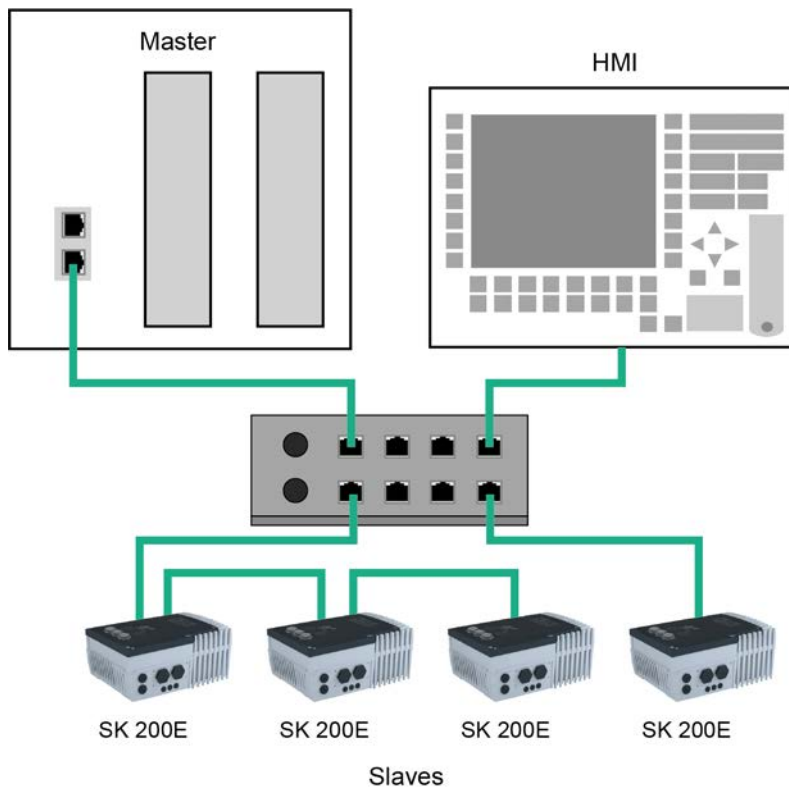

Figure 17: Tree topology (example)

Benefits: Combines the advantages of linear and star topologies, can be easily expanded, simple troubleshooting.

Disadvantages: Operation of the network is not possible in case of problems with the switch.

8 Appendix

8.1 Repair information

In order to keep repair times as short as possible, please state the reason for returning the device and at least one contact in case of queries.

In case of repair, please send the device to the following address:

NORD Electronic DRIVESYSTEMS GmbH

Tjüchkampstraße 37
26606 Aurich

Information

Third party accessories

Getriebebau NORD GmbH & Co. KG cannot accept liability for third party accessories if these are returned with the device.

Information

Accompanying document

Please complete the accompanying document for the return. This can be found on our homepage www.nord.com or directly under the link [Warenbegleitschein](#)

In case of queries about repairs please contact:

Getriebebau NORD GmbH & Co. KG

Tel.: +49 (0) 45 32/ 289-2515
Fax: +49 (0) 45 32 / 289-2555

8.2 Documents and software

Documents and software can be downloaded from our website www.nord.com.

Other applicable documents and further information

Documentation	Contents
AG 0104	System Bus, functional description
BU 0000	Manual for use of NORDCON software
BU 0180	Instruction manual for the NORDAC <i>BASE</i> frequency inverter
BU 0200	Instruction manual for the NORDAC <i>FLEX</i> frequency inverter
BU 0250	Instruction manual for the NORDAC <i>LINK</i> frequency inverter
BU 0950	Manual – TIA standard modules
TI 275271027	Tech. information / data sheet SK CU4-ETH
TI 275271527	Tech. information / data sheet SK CU4-ETH-C
TI 275281132	Tech. information / data sheet SK TU4-ETH
TI 275281182	Tech. information / data sheet SK TU4-ETH-C
TI 275281233	Tech. information / data sheet SK TU4-ETH-M12
TI 275281283	Tech. information / data sheet SK TU4-ETH-M12-C

Software

Software	Description
Device description files	Device description file for configuration software in Industrial Ethernet
NORDCON	Parameterisation and diagnostic software

Key word index

A

Access TU IOs (P154).....	70
Accompanying document.....	88
Active assembly (P879).....	79
Actual bus protocol (P870).....	78
Actual value	
IW.....	27, 43
Actual values.....	20
Additional parameters.....	82
Addressing mode (P856).....	73
Ambient temperature (P178).....	77
Application data.....	41

B

Binary transmission.....	20
Bus node.....	21
Bus protocol.....	25
Bus state (P872).....	78

C

CAN bus address (P515).....	21
CAN bus baud rate (P514).....	22
CAN ID.....	21
CAN over EtherCAT (CoE).....	28
CANopen.....	21
Change bus protocol (P899).....	71
Client/Server principle.....	34
Configuration (P172).....	76
Control bit.....	14
Control word.....	14, 18
CTW.....	27, 43

D

Data record transfer	
Examples.....	52
Data sets	
Parameter requests.....	46, 48
Device characteristics.....	56
Device description file.....	43, 56, 57, 58, 60
Device detection.....	57, 58
Device Name (P854).....	75
Documents	
Other applicable.....	89

E

Electrician.....	11
Error messages.....	68, 76, 83
Bus interface.....	83
Error monitoring.....	68, 76, 83
EtherCAT	
Characteristics.....	24
Parameter (CoE directory).....	28
telegram.....	25
EtherCAT state machine (ESM).....	26

F

Factory settings (P152).....	68
Field bus address.....	58
Firmware update.....	63
Firmware update via FoE.....	30, 63
Firmware update via TCP.....	65
Firmware update with EtherCAT.....	30, 63
Firmware update with EtherCAT.....	30
Firmware update with EtherNet/IP or PROFINET IO.....	65
FoE functionality.....	30
FW-Update Management (P895).....	71

H

Hot-Connect function.....	25
---------------------------	----

I

IO	
Controller.....	36
device.....	36
supervisor.....	36
IP Address (P850).....	72, 74
IP Gateway (P852).....	73, 74
IP Subnetmask (P851).....	72, 74

M

MAC Address (P878).....	79, 80
Min.SystembusCycle (P153).....	69

N

NORD	
Parameter numbers.....	28
NORD system bus.....	21
NORDCON computer.....	21

O		PZD bus out (P874)	78
OSI layer model	31		
P		R	
P170 Actual Error	76	Records	47
Parameter	67, 82	Remote maintenance	23
Data transmission	28, 34	Repairs	88
index	50	Request ID	49
request	47	Response ID	49
response	47	Returns	88
Settings	82	S	
Parameter data transmission	46	SDO error codes	29
Parameter requests		Second Address (P850)	72
Format	48	Setpoint	
Parameter value PWE2		SW	27, 43
Error messages	50	Setpoints	20
Parameterisation		Setting the field bus protocol	56
PPO1 or PPO2	55	Software	89
Percentage transmission	20	Software-Version (P171)	76
Permissible write cycles	46	State of digital in. (P174)	77
PKW area	48	Status bit	15
PPO type	43	Status Dip-switches (P190)	77
PPO1	44	Status machine	
PPO2	45	Frequency inverter	16
PPO3	44	Status word	15, 19
PPO4	44	STW	27, 43
PPO6	44	T	
PPO-Type (P879)	81	TCP Ethernet rights (P853)	70
Present IP address (P875)	79, 80	TimeOut External Bus (P151)	68
Present IP gateway (P877)	80	Topology	24, 32, 37
Present IP sub-net mask (P867)	79, 80	Linear	84
Process data	66	Ring	86
Process data telegram	27	Star	85
Process data telegrams	44	Tree	87
PROFIBUS profile	43	Transfer of process data	27, 43, 66
PZD bus in (P873)	78	Transmission of positions	20

Headquarters
Getriebebau NORD GmbH & Co. KG
Getriebebau-Nord-Str. 1
22941 Bargteheide, Deutschland
T: +49 45 32 / 289 0
F: +49 45 32 / 289 22 53
info@nord.com