

OPERATING INSTRUCTIONS

NORDAC *vector* Frequency Inverter

SK 1500/3 CT ... SK 132000/3 CT
SK 2200/3 VT ... SK 37000/3 VT

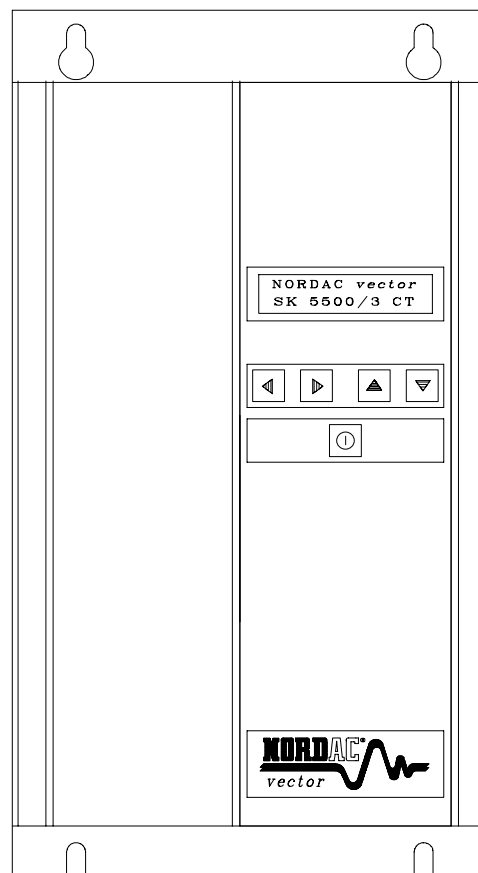

BU 4000/00 GB

GETRIEBEBAU NORD

GmbH & Co. KG



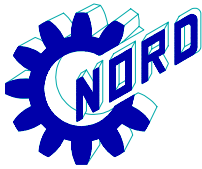

NORDAC *vector* frequency inverter

Safety and operating instructions



for driving current converters

in conformity with the low-voltage directive 73/23/EEC

1. General

In operation, drive converters, depending on their degree of protection, may have live, uninsulated, and possibly also moving or rotating parts, as well as hot surfaces.

In case of inadmissible removal of the required covers, of improper use, wrong installation or maloperation, there is the danger of serious personal injury and damage to property.

For further information, see documentation.

All operations serving transport, installation and commissioning as well as maintenance are to be carried out by skilled technical personnel (Observe IEC 364 or CENELEC HD 384 or DIN VDE 0100 and IEC 664 or DIN/VDE 0110 and national accident prevention rules!).

For the purposes of these basic safety instructions, "skilled technical personnel" means persons who are familiar with the installation, mounting, commissioning and operation of the product and have the qualifications needed for the performance of their functions.

2. Intended use

Drive converters are components designed for inclusion in electrical installations or machinery.

In case of installation in machinery, commissioning of the drive converter (i.e. the starting of normal operation) is prohibited until the machinery has been proved to conform to the provisions of the directive 89/392/EEC (Machinery Safety Directive - MSD). Account is to be taken of EN 60204.

Commissioning (i.e. the starting of normal operation) is admissible only where conformity with the EMC directive (89/336/EEC) has been established.

The drive converters meet the requirements of the low-voltage directive 73/23/EEC. They are subject to the harmonized standards of the series prEN 50178/DIN VDE 0160 in conjunction with EN 60439-1/ VDE 0660, part 500, and EN 60146/ VDE 0558.

The technical data as well as information concerning the supply conditions shall be taken from the rating plate and from the documentation and shall be strictly observed.

3. Transport, storage

The instructions for transport, storage and proper use shall be complied with.

The climatic conditions shall be in conformity with prEN 50178.

4. Installation

The installation and cooling of the appliances shall be in accordance with the specifications in the pertinent documentation.

The drive converters shall be protected against excessive strains. In particular, no components must be bent or isolating distances altered in the course of transportation or handling. No contact shall be made with electronic components and contacts.

Drive converters contain electrostatic sensitive components which are liable to damage through improper use. Electric components must not be mechanically damaged or destroyed (potential health risks).

5. Electrical connection

When working on live drive converters, the applicable national accident prevention rules (e.g. VBG 4) must be complied with.

The electrical installation shall be carried out in accordance with the relevant requirements (e.g. cross-sectional areas of conductors, fusing, PE connection). For further information, see documentation.

Instructions for the installation in accordance with EMC requirements, like screening, earthing, location of filters and wiring, are contained in the drive converter documentation. They must always be complied with, also for drive converters bearing a CE marking. Observance of the limit values required by EMC law is the responsibility of the manufacturer of the installation or machine.

6. Operation

Installations which include drive converters shall be equipped with additional control and protective devices in accordance with the relevant applicable safety requirements, e.g. Act respecting technical equipment, accident prevention rules etc. Changes to the drive converters by means of the operating software are admissible.

After disconnection of the drive converter from the voltage supply, live appliance parts and power terminals must not be touched immediately because of possibly energized capacitors. In this respect, the corresponding signs and markings on the drive converter must be respected.

During operation, all covers and doors shall be kept closed.

7. Maintenance and servicing

The manufacturer's documentation shall be followed.

KEEP SAFETY INSTRUCTIONS IN A SAFE PLACE!

1 GENERAL	2
1.1 Delivery	2
1.2 Scope of delivery	2
1.3 Safety and installation instructions.....	2
2 INSTALLATION	4
3 ILLUSTRATED DIMENSIONS	5
3.1 Frequency inverter dimensions	5
4 CONNECTION	6
4.1 Power section SK 1500/3 CT to SK 132000/3 CT.....	6
4.2 Control section.....	8
4.2.1 Cable entry	8
4.2.2 Control terminal strip.....	9
4.2.3 Control inputs.....	10
5 OPERATION AND DISPLAYS	13
5.1 Display	13
5.2 Keyboard	13
5.3 Relays.....	13
6 STARTING-UP	14
6.1 Parameter settings at system start-up	14
6.2 Selecting the national language.....	16
7 MENU GROUPS AND MENU ITEMS	16
7.1 Menu items in tables	18
7.1.1 Basic parameters	18
7.1.2 Motor data	19
7.1.3 Control parameters	20
7.1.4 Control terminals.....	24
7.1.5 Extra functions	30
7.1.6 Information parameters.....	34
7.1.7 Service parameters.....	35
7.2 Menu item information	36
7.2.1 Operating mode (basic parameters)	36
7.2.2 Keyboard control (extra functions)	38
7.2.3 Fixed frequencies	38
7.2.4 USS mode	39
7.2.5 Speed controller.....	40
8 SETTINGS AFTER THE FIRST STARTING-UP	43
8.1 Basic parameters.....	43
8.2 Motor data	43
8.3 Control parameters	43
8.4 Control terminals.....	44
8.5 Extra functions	45
9 WARNINGS AND FAULTS	47
9.1 List of warnings and error messages included in the programme.....	47
9.2 Possible overcurrent (W/F).....	49
9.3 Quick stop at major faults	49
9.4 System errors 1-13	49
9.5 Max. mains voltage switching cycles	49
10 EMC MEASURES	50
10.1 Radio interference suppression level	50
10.2 Noise immunity	50
11 CE MARKING	50
12 ADDITIONAL MEASURES (OPTIONAL EQUIPMENT)	51
12.1 Mains filters.....	51
12.2 Installation and dimensions of mains filters.....	51
12.3 Brake resistor data and dimensions.....	53
12.4 Output chokes.....	54
12.5 Sine output filters	54
13 MAINTENANCE AND SERVICE INFORMATIONN	54
14 NORDAC VECTOR FOR SQUARE LOAD TORQUE (VT)	54
15 TECHNICAL DATA	55
15.1 General technical data.....	55
15.2 Technical data, constant torque (CT → <u>C</u> onstant <u>T</u> orque).....	55
15.3 Technical data, variable torque (VT → <u>V</u> ariable <u>T</u> orque).....	57

1 General

NORDAC *vector* frequency inverters are all-digitized microprocessor-controlled voltage source d.c. link inverters designed to control the speed of three-phase motors. *Multiple control functions, optimized power characteristics, easy handling, compact design and high operational dependability* are the special characteristics of these inverters.

NORDAC *vector* frequency inverters are available as CT (**C**onstant **T**orque) and VT (**V**ariable **T**orque) devices. The VT type is particularly suitable for applications where a square load torque of the working machine is to be ensured, like e.g. for fan or pump drives. The CT type lends itself to all the other applications, especially to those in which a linear load torque is desirable (cf. section 14).

1.1 Delivery

Examine the device **immediately** after arrival/unpacking for transport damage such as distortions or loose parts.

In case of damage contact the transport company without delay and ensure that the damage is ascertained very carefully.

Important! This provision shall apply even if the packaging is undamaged.

1.2 Scope of delivery

Standard package: IP 20 panel mounting unit
Operating instructions
Integrated clear text display
Integrated brake-chopper
RS 485 serial interface

Accessories available: IP 20 braking resistor
(optional equipment) Mains filter for a high level of radio interference suppression
Interface converter RS 232 → RS 485
NORDCON software for parameter setting
Incremental shaft encoder input for speed control
posicon add-on card for positioning control
Profibus add-on assembly for Profibus – DP
Canbus add-on assembly for Canbus

Special version: Device with painted boards resistant to aggressive ambient air.

1.3 Safety and installation instructions

NORDAC *vector* frequency inverters are electrical equipment for application in industrial power plant and operated at voltages which may cause serious injuries or even death should any live parts be touched.

- Installation and any other work on the device shall be carried out by skilled and properly qualified technical personnel only. The operating instructions must be available to such personnel any time and must be adhered to in every respect.
- The local regulations applicable to the installation of electrical systems as well as accident prevention regulations have to be observed.
- The device is still dangerously live up to 5 minutes after having been disconnected from the mains. Accordingly the device must not be opened until by the end of 5 minutes after power has been switched off. Reattach all covers before switching the mains voltage on again.
- Even when the motor has stopped (e.g. following electronic disable or as a result of a jam situation or a short circuit of the output terminals), the mains terminals, motor terminals and terminals for the braking

resistor can be dangerously live. A motor stop does not mean that the inverter is electrically isolated from the mains.

- **Caution**, parts of the control board are dangerously live, too. Only the control terminals are not at mains potential.
- **Caution**, certain setting configurations may cause the inverter to start up on its own when the mains is switched on.
- The printed circuit boards carry highly sensitive MOS semiconductor components which are easily impaired by static electricity. Be careful therefore not to touch the conductive tracks or electronic components with your hands or metal objects. Only the screws of the terminal strips may be touched with insulated screwdrivers while connecting the lines.
- The frequency inverter is designed for permanent connection exclusively and must not be operated without effective earthing as stipulated in the local regulations concerning high leakage currents (> 3,5 mA). VDE 0160 demands that either a second earth conductor be installed or that the earth conductor cross section be 10 mm² minimum.
- If according to local regulations no direct current component must be contained in the fault current, conventional earth-leakage circuit-breakers do not afford sufficient protection.
- NORDAC *vector* frequency inverters are maintenance-free provided that they are properly operated in accordance with instructions. If the air is dust-laden the cooling surfaces need to be regularly cleaned with compressed air.

CAUTION! DANGER!

**The power section can still be live up to 5 minutes after disconnection from the mains!
Inverter terminals, motor supply cables, and motor terminals can still be live !**

**Touching exposed or unconnected terminals, cables or parts of the device can lead to
serious injuries or even death!**

For the NORTH-AMERICAN market :

- The *vector* inverter is suitable for connection to a power supply system with a short-circuit current of 5000 A (balanced to earth) provided that fuse protection as specified in section 15 is ensured and that voltage will not exceed a maximum of 480V.
- Use copper wire for 60/75°C only.
- Use class 1 copper wire only.
- Suitable for use in an environment with a pollution degree not higher than 2
- Motor starting torque for "field connections".

2 Installation

The devices require sufficient ventilation which is ensured if the recommended minimum values for clearances above and below the units are observed. The values refer to a distance as measured from the upper edge towards any assemblies located above the inverters, and, accordingly, to a distance as measured from the lower edge towards any assemblies arranged below them.

On a horizontal level no extra spacing will be required. The inverters can be installed one right beside the other.

Provide for the hot air rising from the devices to be properly carried off above!

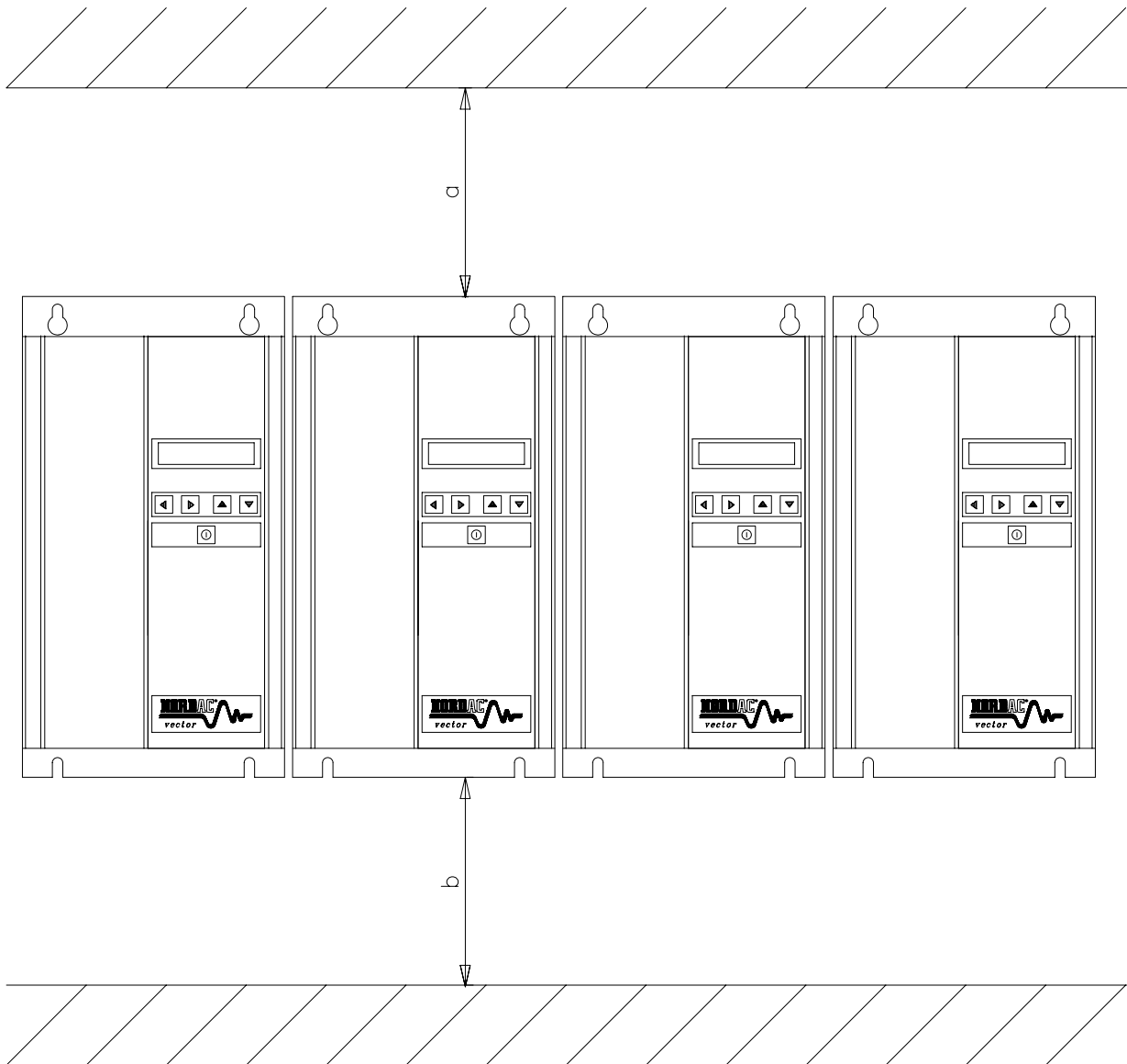

If several inverters are arranged one on top of the other, ensure that the temperature of the air drawn in remains within the allowable limits → 0 ... 40°C

Inverter type	Upward distance, a	Downward distance, b
SK 1500/3 CT to SK 11000/3 CT	130 mm	130 mm
SK 15000/3 CT to SK 22000/3 CT	150 mm	150 mm
SK 30000/3 CT to SK 75000/3 CT	200 mm	200 mm
SK 90000/3 CT to SK 132000/3 CT	250 mm	250 mm

3 Illustrated dimensions

3.1 Frequency inverter dimensions

Version shown : IP 20

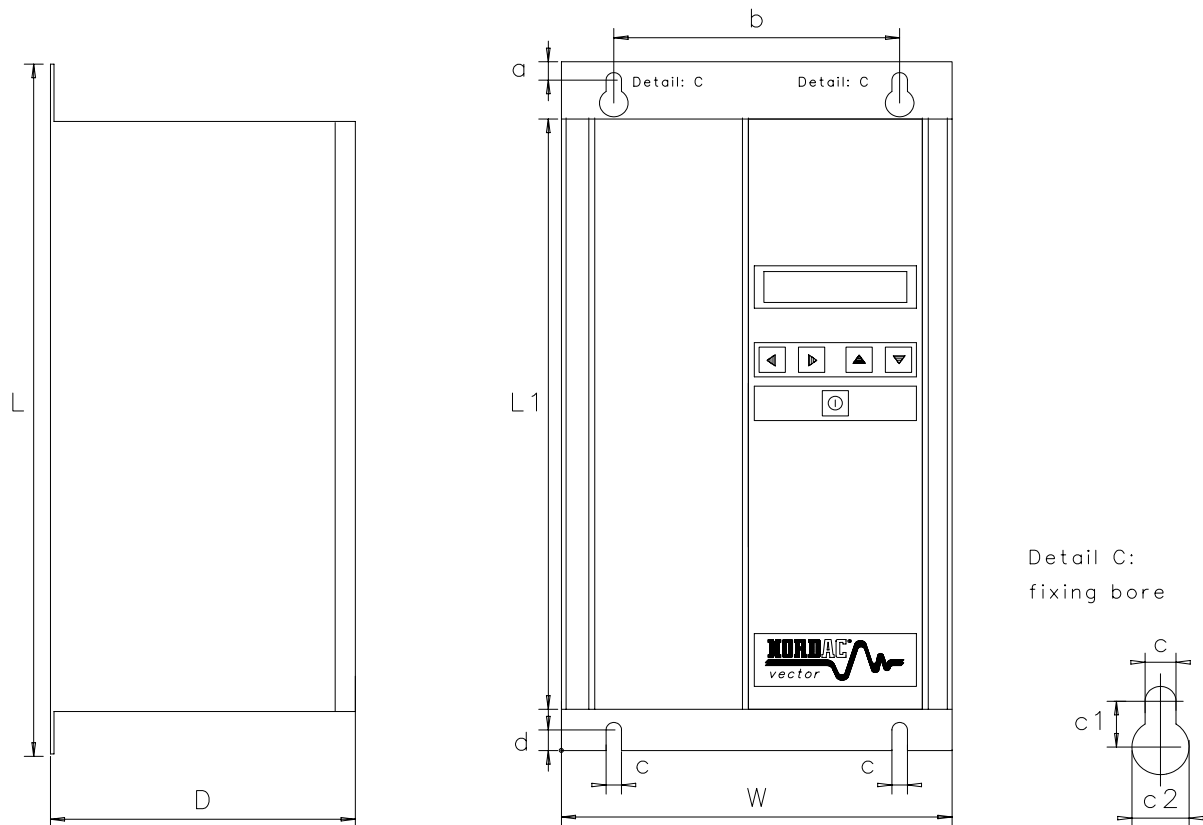

Type	W	D	L	L1	a	b	c	c1	c2	d
SK 1500/3 CT SK 2200/3 CT SK 3000/3 CT	168	184	301	258	8	120	6,5	10	12	9
SK 4000/3 CT SK 5500/3 CT	168	193	341	298	8	120	6,5	10	12	9
SK 7500/3 CT SK 11000/3 CT	168	194	421	378	8	120	6,5	10	12	9
SK 15000/3 CT SK 22000/3 CT	261	248	421	378	8	210	6,5	10	12	9
SK 30000/3 CT SK 37000/3 CT	261	248	599	556	8	210	6,5	10	12	9
SK 45000/3 CT SK 55000/3 CT	261	248	599	556	8	210	6,5	10	12	9
SK 75000/3 CT SK 90000/3 CT	261	321	736	693	8	210	6,5	10	12	9
SK 110000/3CT SK 132000/3CT	352	248	1207	1156	8	**142	6.5	10	12	17

Technical design subject to change All dimensions in mm

** Detail SK 110000/3 CT ... SK 132000/3 CT:

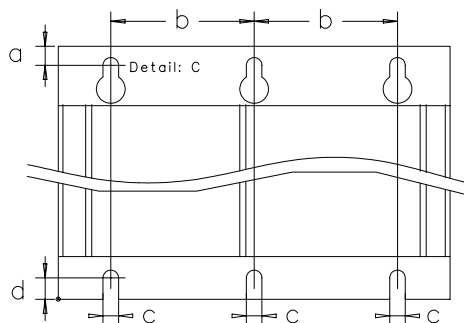

4 Connection

To connect the electrical lines it is necessary to open the unit. The housing cover is attached to the housing by four screws. While working on the inverter be sure to adhere to the Safety and Installation Instructions (cf. section 1.3).

The connecting leads are fed into the device from below and then connected to the power terminal strip. The cable entry plate can be detached to facilitate connection. It is secured with a screw. If this plate is not reinstalled the degree of protection specified for the device is lost.

Control, mains and motor leads should be taken through separate openings. For strain relief metal (PG) screwings can be inserted in the cable entry plate (mains and motor connection up to 37kW). It has to be ensured that the supply conductors are installed in accordance with the local regulations applicable to the installation of electrical systems.

In devices $\geq 45\text{kW}$, the power cables are installed without extra strain relieving provisions (PG screwings) (cf. section 4.2) in view of the fact that the connection terminals are located directly behind the openings in the cover plate.

As for devices $\geq 45\text{kW}$, the control lines should be held in position by means of the cable collars provided inside the unit.

To ensure meeting of the current European Community directives supplementing the EMC law (as from 01.01.1996) a mains filter recommended by the manufacturer of the inverter must be employed along with a shielding of the motor cables. Be sure also to connect the lines properly and to provide an effective earth connection using a midpoint conductor (cf. sections 1.3 and 10.1)

If the cable entry plate is used as a bonding plate for potential equalization, the cable shield has to be connected to the PE terminal in the inverter as well.

4.1 Power section SK 1500/3 CT to SK 132000/3 CT

Connection for mains,
braking resistor and motor:

- via screw-type terminal strips on the lower output stage board

Motor lead:

- approx. 150m max. without additional measures if standard commercial cable is used.
- approx. 75m max. if shielded cable is used

4.1.1 Cable entry

SK 1500/3 CT to SK 11000/3 CT:

A total of 6 through holes sized PG 16 is provided of which 3 are intended to be used for control line and another 3 for power cable connection.

Maximum wire cross-sectional area:

- 4mm^2 for SK 1500/3 CT to SK 7500/3 CT
- 10mm^2 for SK 11000/3 CT

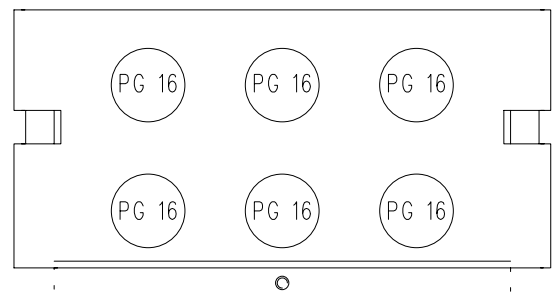

Types SK 15000/3 CT to SK 37000/3 CT:

Use a PG 36 screwing for mains connection, and a PG 29 screwing each to connect braking resistor and motor.

Maximum wire cross-sectional area:

- 16mm^2 (input) for SK 15000/3 CT and SK 22000/3 CT
- 10mm^2 (output) for SK 15000/3 CT and SK 22000/3 CT
- 35mm^2 for SK 30000/3 CT and SK 37000/3 CT

Types SK 45000/3 CT to SK 75000/3 CT:

Mains and motor leads are fed through rectangular openings measuring about 25mm x 83mm each, while the braking resistor line is taken through a clearance approximately 17.5mm x 45mm wide. The connection terminals are located right behind those openings. The inverter housing does not allow for provision of strain relief accessories.

Maximum wire cross-sectional area:

- 50mm² (35mm² for the braking resistor and PE)

Type SK 90000/3 CT:

Mains and motor leads are taken through 4 round (Ø 23mm) openings each, while another round opening (Ø 37.5mm) is provided for the braking resistor connection. The connection terminals are located 35mm behind those openings. The inverter housing allows for provision of a PG screwing to ease the pull on the wires.

Maximum wire cross-sectional area:

- 95mm² (PE 50mm²) mains input / motor output
- 50mm² (PE 35mm²) braking resistor

NOTE: Type SK 90000/3 CT does not provide for a "-ZW" connection terminal!

Types SK 110000/3 CT and SK 132000/3 CT:

Mains and motor leads are taken through 3 round (Ø 25mm) openings each, while a total of 6 round (Ø 20 mm) openings is provided to connect the PE conductor and the braking resistor line. The connection terminals are located right behind those openings. The inverter housing does not allow for provision of strain relief accessories.

Maximum wire cross-sectional area:

- 150mm² mains input / motor output / braking resistor

4.1.2 Electrical connection

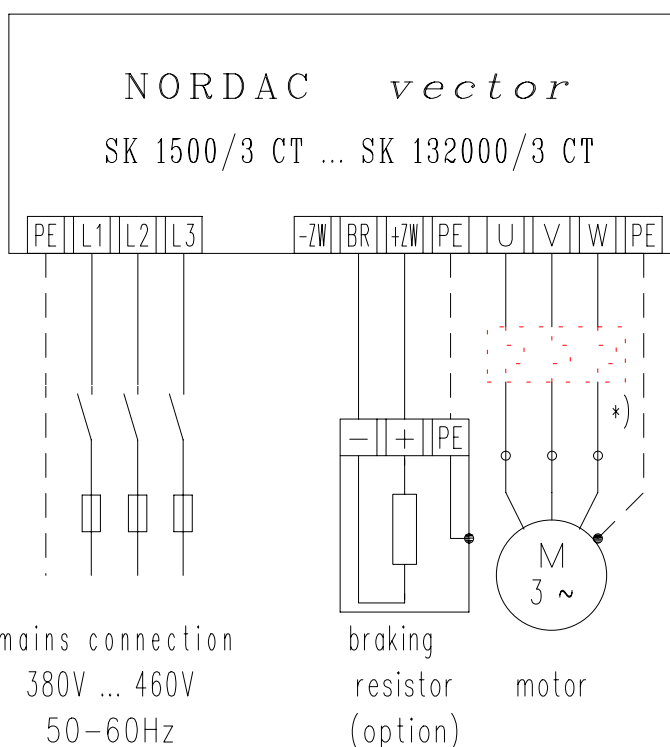

*) To be used as required

A safe motor protection against overtemperature is only guaranteed with a motor temperature detector.

If a motor PTC resistor is used, the line routing should be different from that of the motor cable. It may even be advisable to provide a cable shielding.

4.2 Control section

- Control wires to be connected to: - 29-pole control terminal strip, divided into 5 blocks
 Changeover switch for the analog setpoint: - 2-pole DIP switch on the control board
 Terminating resistance for RS485: - Jumper connects terminating resistor into circuit

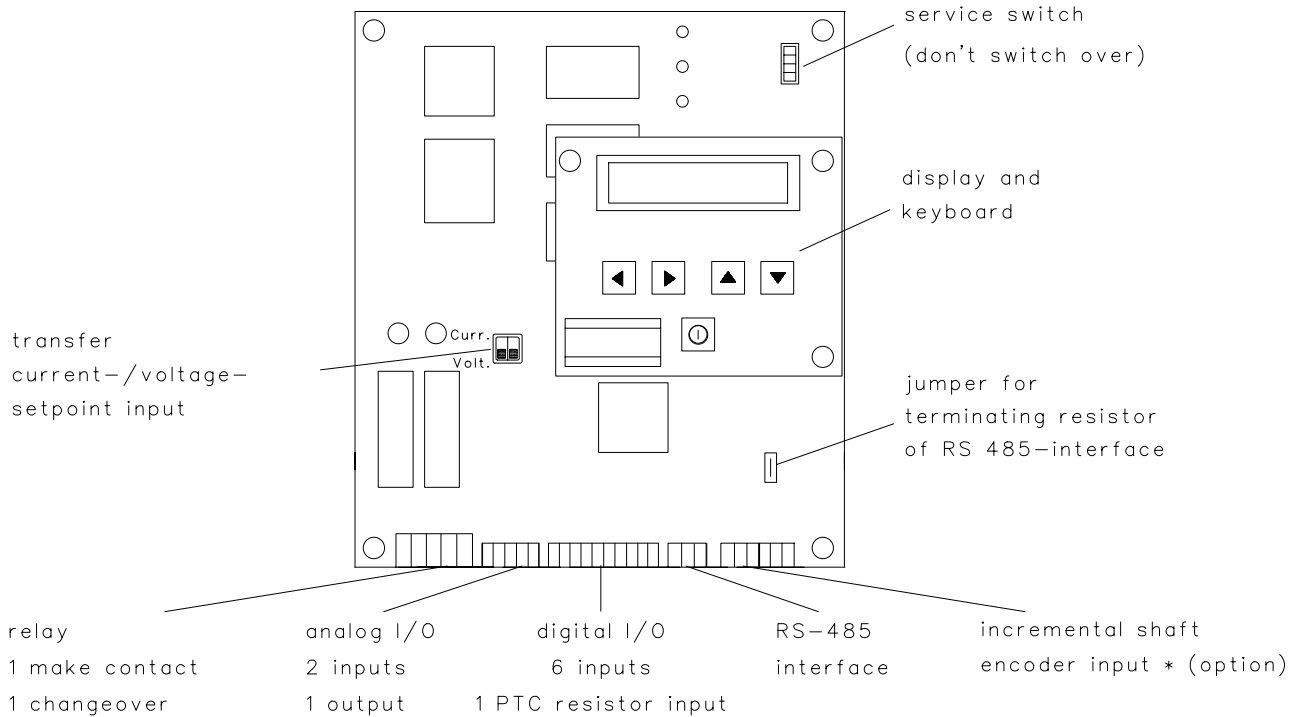

*) only if the optional incremental shaft encoder input has been provided!
 (cf. item 7.2.5)

4.2.1 Cable entry

Types SK 1500/3 CT to SK 11000/3 CT:

A number of 6 openings sized PG 16 is provided to be used as required for entering control and power cables, with 3 openings for each type.

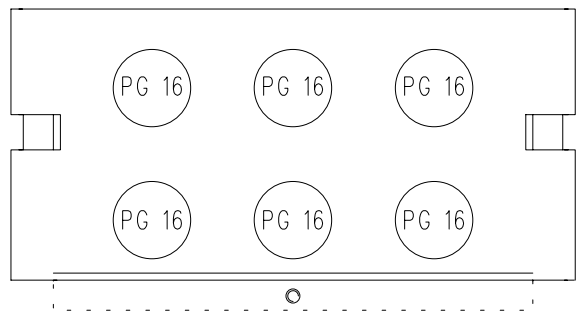

Types SK 15000/3 CT to SK 132000/3 CT:

Three PG 16, one PG 11 and one PG 13.5-size screwings are provided to allow control line connection.

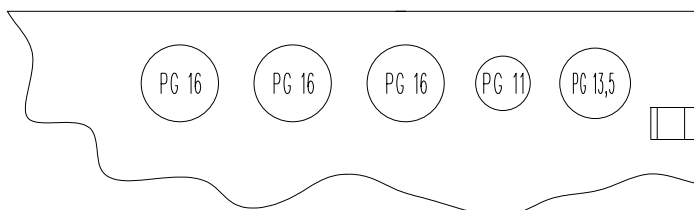

4.2.2 Control terminal strip

- Maximum connection cross-section: - 1.5 mm² for analog in- and outputs
 - 2.5 mm² for relay outputs
- Cables: - lay separately from mains/motor leads and shield if necessary

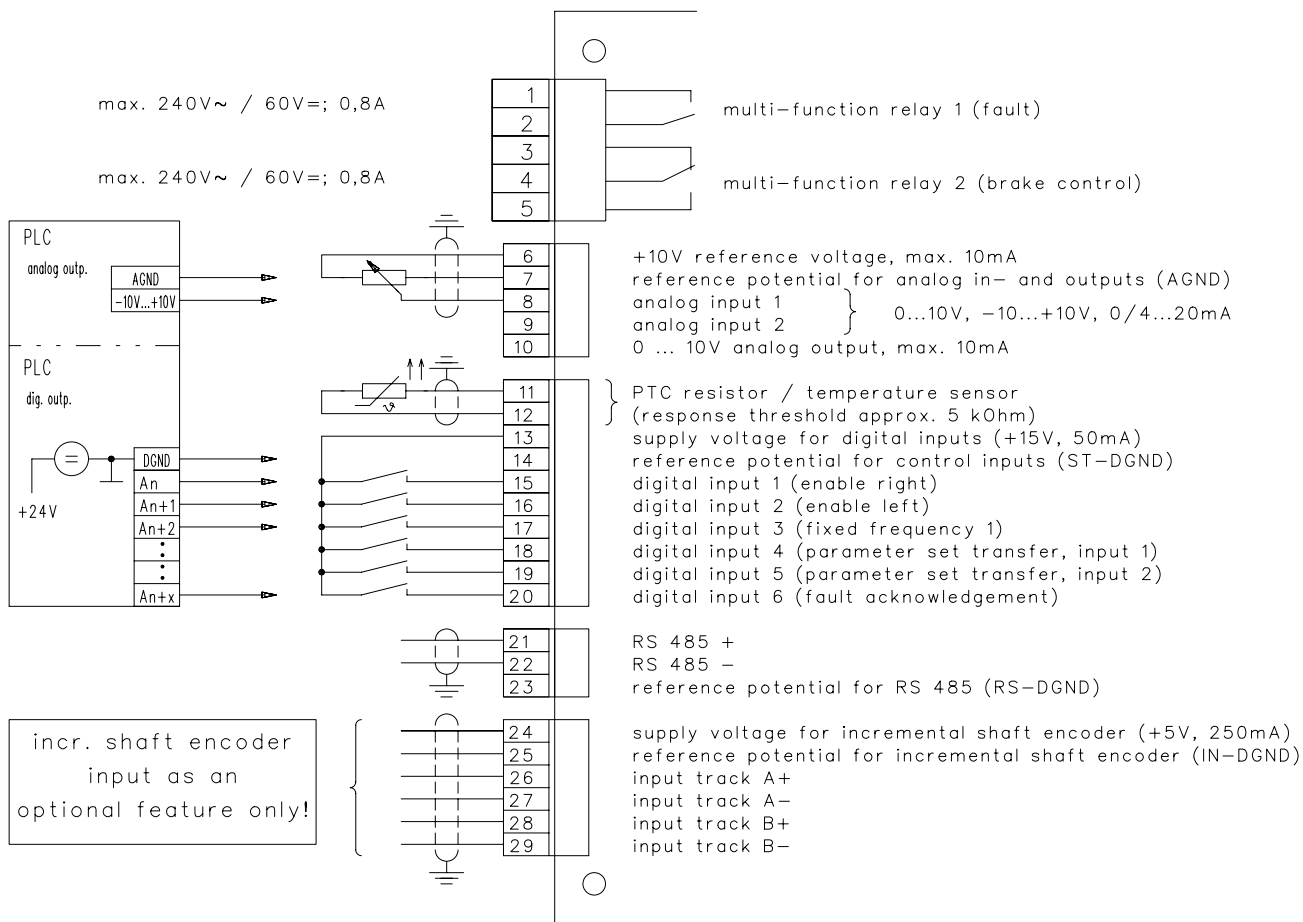

The factory settings of the relay functions and digital inputs are added in brackets.

PLEASE NOTE: Being internally connected to one another, all GND terminals on the control card must be at one potential!

4.2.3 Control inputs

Terminal	Function / comments	Data	Circuit / Suggested circuit
1 2	<p>Relay 1, make contact element</p> <p>Contact is open:</p> <ul style="list-style-type: none"> inverter is disconnected from the mains inverter disturbance programmed limiting value / condition has been reached <p>Contact is closed :</p> <ul style="list-style-type: none"> inverter is ready for operation programmed limiting value has <u>not</u> been reached yet 	<p>max. 240V~ / 60V= 0,8A</p> <p>terminals: 2.5mm²</p>	
3 4 5	<p>Relay 2, changeover contact</p> <p>Contact 3-4 is closed :</p> <ul style="list-style-type: none"> non-operative position inverter is disconnected from the mains <p>Contact change-over, 4-5 is closed:</p> <ul style="list-style-type: none"> programmed limiting value / condition has been reached 		
6 7 8 9	<p>Reference voltage for analog inputs Power handling capacity:</p> <p>Reference potential for analog in- and outputs</p> <p>Analog input 1</p> <p>Analog input 2</p> <p>input resistance at voltage setpoint: current setpoint:</p>	<p>+10V max. 10mA</p> <p>AGND</p> <p>0...10V, ±10V 0/4...20mA</p> <p>0...10V, ±10V 0/4...20mA</p> <p>approx. 40kΩ approx. 250Ω</p> <p>terminals: 1.5mm²</p> <p>R = 1 ... 10kΩ 2 x R = 2 ... 10kΩ ±10V 0/4 ... 20mA</p>	

Terminal	Function / comments	Data	Circuit / Suggested circuit
10	<p>Analog output</p> <p>Power handling capacity:</p> <p>Analog voltage being put out corresponding to the output frequency*, the output current, the output voltage, the active power, the $\cos \varphi$, the motor torque* or the motor speed*</p>	<p>0 ... 10V</p> <p>max. 10mA</p> <p>terminals: 1.5mm²</p> <p>*depending on sign; possible:</p> <p>positive \Rightarrow 5-10V</p> <p>negative \Rightarrow 0-5V</p>	
11 12	<p>Motor PTC resistor input</p> <p>Lay the (shielded) connecting cable separately from mains and motor cables.</p>	<p>Response threshold:</p> <p>approx. 5 kΩ</p> <p>terminals: 1.5mm²</p> <p>(cf. item 7.1.4)</p>	
<p>In the factory a jumper is connected. To connect a PTC resistor, remove this jumper and activate the motor temperature protection (control terminals, 7.1.4).</p>			
13 14 15 16 17 18 19 20	<p>Power supply for control inputs</p> <p>Power handling capacity:</p> <p>Reference potential for the control inputs</p> <p>Control input 1</p> <p>Control input 2</p> <p>Control input 3</p> <p>Control input 4</p> <p>Control input 5</p> <p>Control input 6</p> <p>Input resistance:</p>	<p>+15V</p> <p>max. 50mA</p> <p>low level: 0...3V</p> <p>high level: 13...30V</p> <p>positive logic</p> <p>terminals: 1.5mm²</p> <p>approx. 5.7kΩ</p>	<p>a)</p> <p>b)</p>
21 22 23	<p>Interface input</p> <p>RS 485 +</p> <p>RS 485 -</p> <p>Reference potential for RS 485 interface</p> <p>Terminating resistance $R \approx 120\Omega$</p>	<p>terminals: 1.5mm²</p> <p>(cf. item 4.3)</p>	

OPTION: Incremental shaft encoder input, RS 422

24 25 26 27 28 29	<p>Power supply</p> <p>Reference potential for supply</p> <p>Input track A+</p> <p>Input track A-</p> <p>Input track B+</p> <p>Input track B-</p>	<p>+5V, max. 250mA</p> <p>IN-DGND</p> <p>max. 250kHz</p> <p>terminals: 1.5mm²</p> <p>(cf. item 7.2.5)</p>	<p>OPTION</p>
----------------------------------	---	--	---------------

NOTE: The rotating field of the shaft encoder must be identical to that of the motor. If it isn't (e.g. in NORD motors with HG 660 transducer), tracks A+ and A- must be exchanged.

PLEASE NOTE: Being internally connected to one another, all GND terminals on the control card must be at one potential!

4.2.3.1 Assignment of colours and contacts for incremental shaft encoders

Function	Colour (with HG 660 incremental encoder)	Inputs on <i>NORDAC vector</i>	Inputs on <i>NORDAC vector posicon</i>
5V supply	red	24	22
0V supply	blue	25	23
Track A +	white	26	24
Track A -	brown	27	25
Track B +	pink	28	26
Track B -	black	29	27
Track 0 +	violet	--	28
Track 0 -	yellow	--	29
Shield	shield	PE	PE

Use a connector with a metal or metallised housing and connect the housing to the cable shield.

5 OPERATION AND DISPLAYS

General :

- Two-line liquid-crystal display with 16 digits in each line
- 5 keys for operation

5.1 Display

After mains switch-on, the display will show the *inverter type* being used, e.g.

```

NORDAC vector
SK 2200/3 CT
    
```

Following release, the device shows the *major operating data*, e.g.

```

P1 F/HZ U/V I/A
R 0.0 0 0.0
    
```

The display shows the menu item for as long as the relevant parameter is being adjusted, e.g.

```

Acceleration time
2.00s P1
    
```

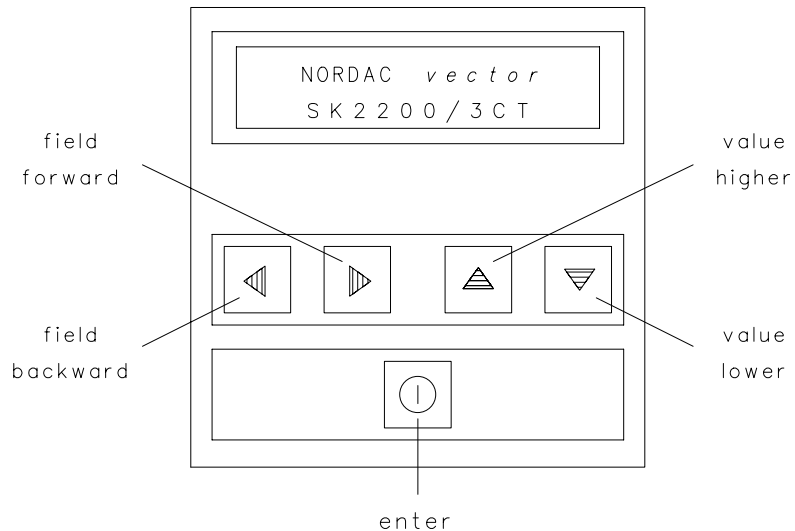

5.2 Keyboard

With the two „*field keys*“ you can page forward and backward within the range of menu groups and menu items available for selection. When both keys are pressed the display will show the choice of menu groups, or when both keys are pressed twice it will return to indicating either the inverter type or the operating data .

To call the selected menu group or to adopt/store a menu item that has been changed, the "Enter key" is operated.

With the two "*value keys*" the values or contents of any individual menu item are changed. Changes have to be transferred into memory using the *Enter key*, otherwise the previous value will remain. To call attention to such changes which have not yet been confirmed with the Enter command, either the unit of measurement or a star symbol will be flashing.

If the „*value keys*“ are operated at the same time the factory setting relating to this menu item is shown and can be reactivated.

Keeping the *field* or *value keys* pressed will make the contents change in a continuous fashion. Pushing the keys just once will make the contents change step by step.

The longer the value keys are being pressed, the faster the display of the contents will change. In other words, holding the keys down will accelerate the rate at which different values or contents are displayed.

5.3 Relays

The pilot relays which are integrated in the frequency inverter can be programmed for various functions. The desired function is selected with the *left value key*. To switch the selected function ON or OFF, the *right value key* is used. The input is saved with the *Enter key* (cf. item 7.1.4 Control terminals, MFR1 or MFR2).

6 Starting-up

6.1 Minimum configuration of the control terminals

To operate the NORDAC vector on a minimum configuration basis, after turning on the mains power

- a) activate the electronic enable function (connect control terminal 15 to a "high" signal [edge], e.g. to terminal 13) and
- b) apply an analogue voltage setpoint (0 to 10V) between control terminals 7 and 8.

Proposed assignment of terminals on control terminal strip:

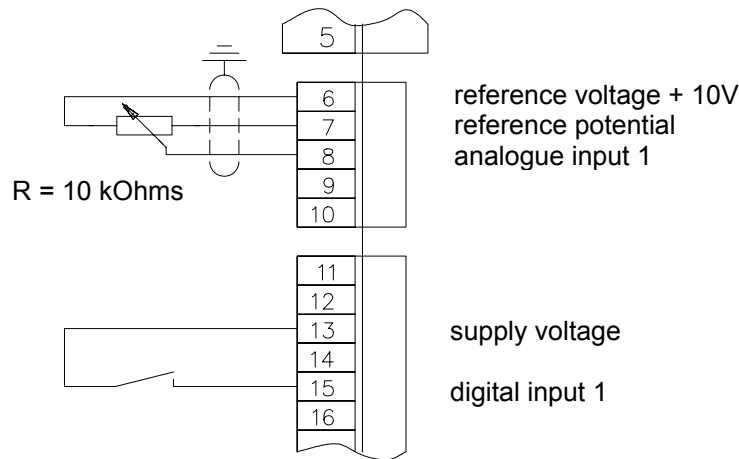

6.2 Major basic settings

On delivery the NORDAC vector frequency inverter settings are such that to operate the matching 4-pole standard motor no other presetting will be required.

If the rating of the motor does not correspond to the rated output the inverter settings are based on, check whether the difference is significant enough to require a change of the settings provided.

Excerpt from the parameter list:

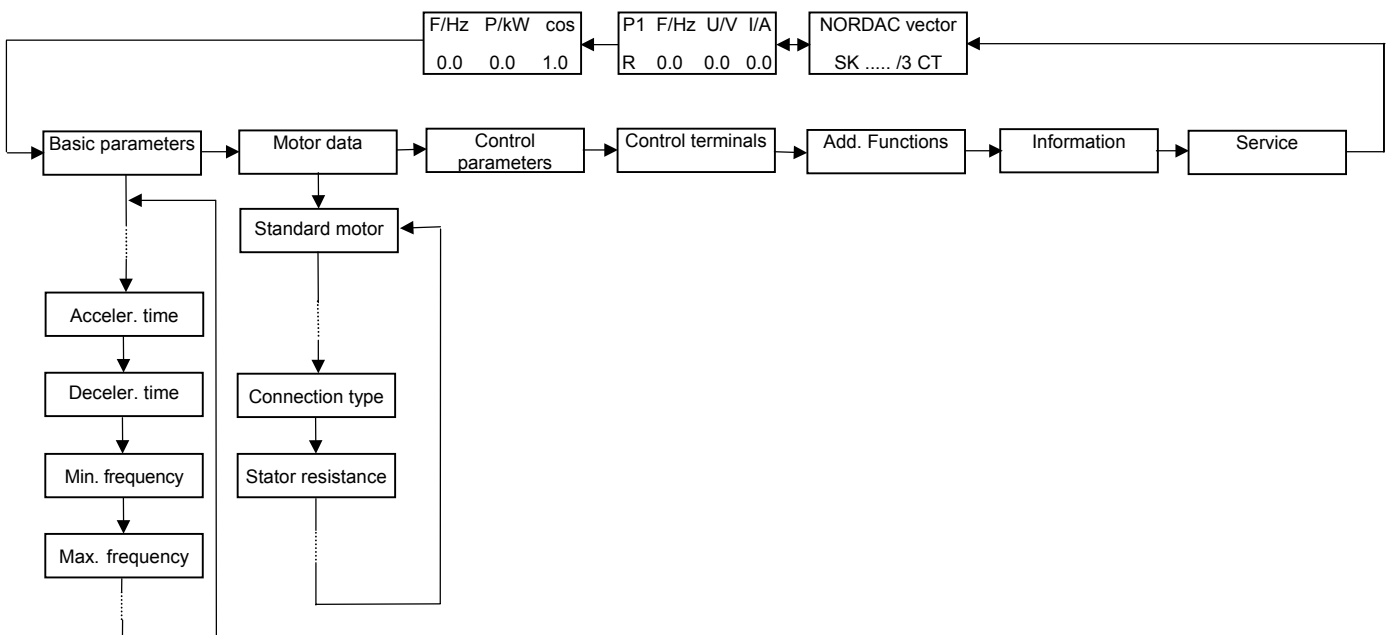

6.3 Parameter settings at system start-up

The following menu items are available (and can be viewed) with presettings:

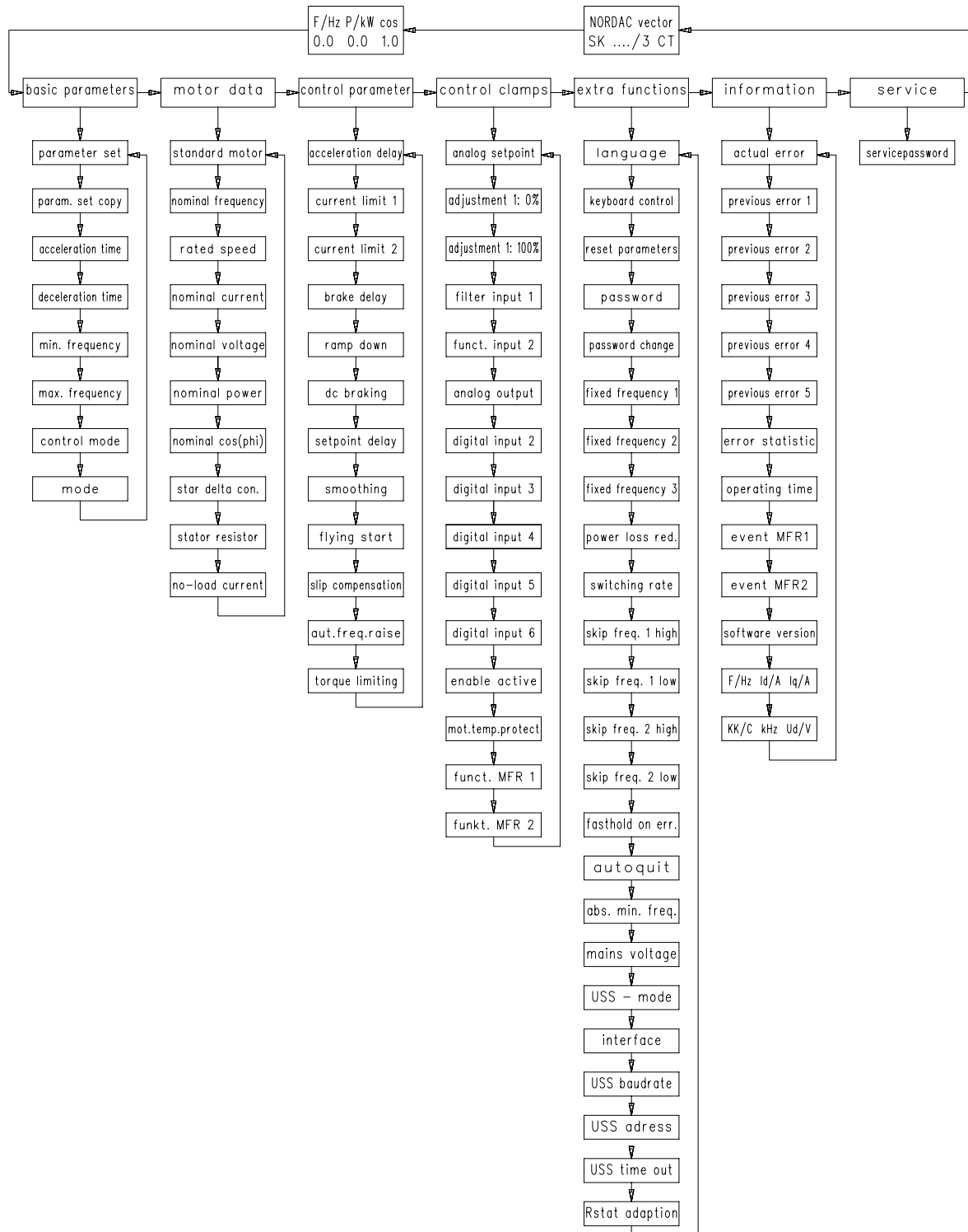

The principal parameters such as the minimum and the maximum frequency or the acceleration and deceleration time can be changed now if required in the "Basic Parameters" menu group.

If the frequency inverter is supposed to control a motor other than the standard motor to which it is allocated (based on the inverter's rated output), the characteristic data of this motor have to be entered in the "Motor data" menu group.

If this other motor is a 4-pole three-phase a.c standard type, it can be selected in the "Standard motor" menu item on the basis of its rated power. All necessary motor data are already preset.

If other motors than these are involved, read the nameplate data and enter them into the relevant menu items.

The inverter will measure the "Stator resistance" automatically when the contents of the respective menu item is set to „0“ followed by operation of the „Enter key“. For the measured value to be correctly interpreted it is essential first to set the connection type of the motor (star or delta).

6.4 Selecting the national language

"German" is factory-set for communication with the inverter. To change the language in which the information will be displayed proceed as demonstrated below:

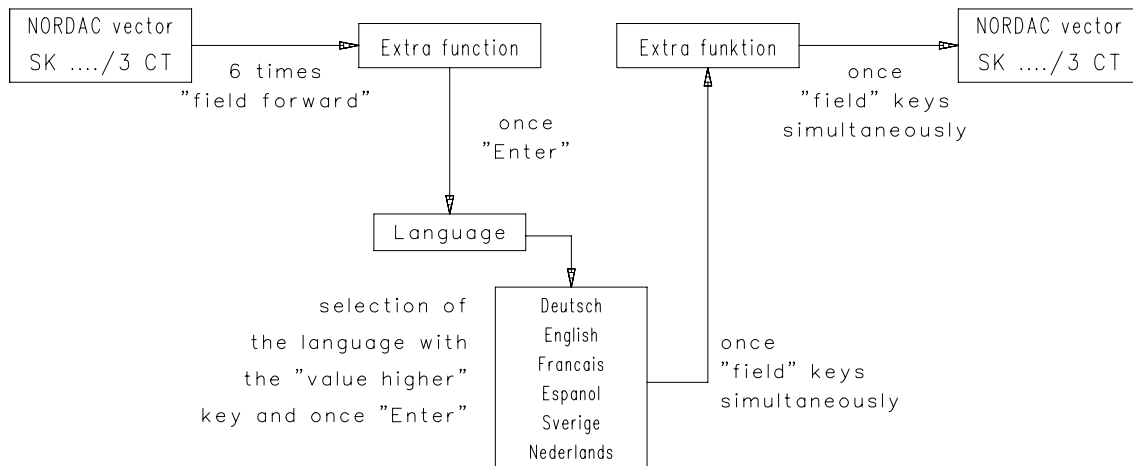

7 MENU GROUPS AND MENU ITEMS

Each *menu item* belongs to one of a couple of *menu groups*. The various *menu groups* cover the following functions:

- Basic parameters: → are sufficient for standard applications. Represent basic inverter settings.
- Motor data: → adjustment of the specific motor data. Important with regard to ISD current control. If a linear V/f characteristic is selected, only the standard motor information is displayed. In that case the parameters "V/f break point" and "Boost" included in the control parameters are relevant.
- Control parameters: → control the voltage/frequency characteristic curve at the inverter output and the inverter action in the case of imminent overcurrent, overvoltage etc.
- Control terminals: → determine the setpoint inputs, the analog output, the digital inputs and the relay functions.
- Extra functions: → are functions which are provided in addition to the fundamental inverter functions, as for instance language, fixed frequencies, pulse frequencies or the RS485 interface
- Information parameters: → indicate present and past disturbances, operating time and software version.
- Service parameters: → are used for final quality inspection. They are locked with a service-password and inaccessible to the user.

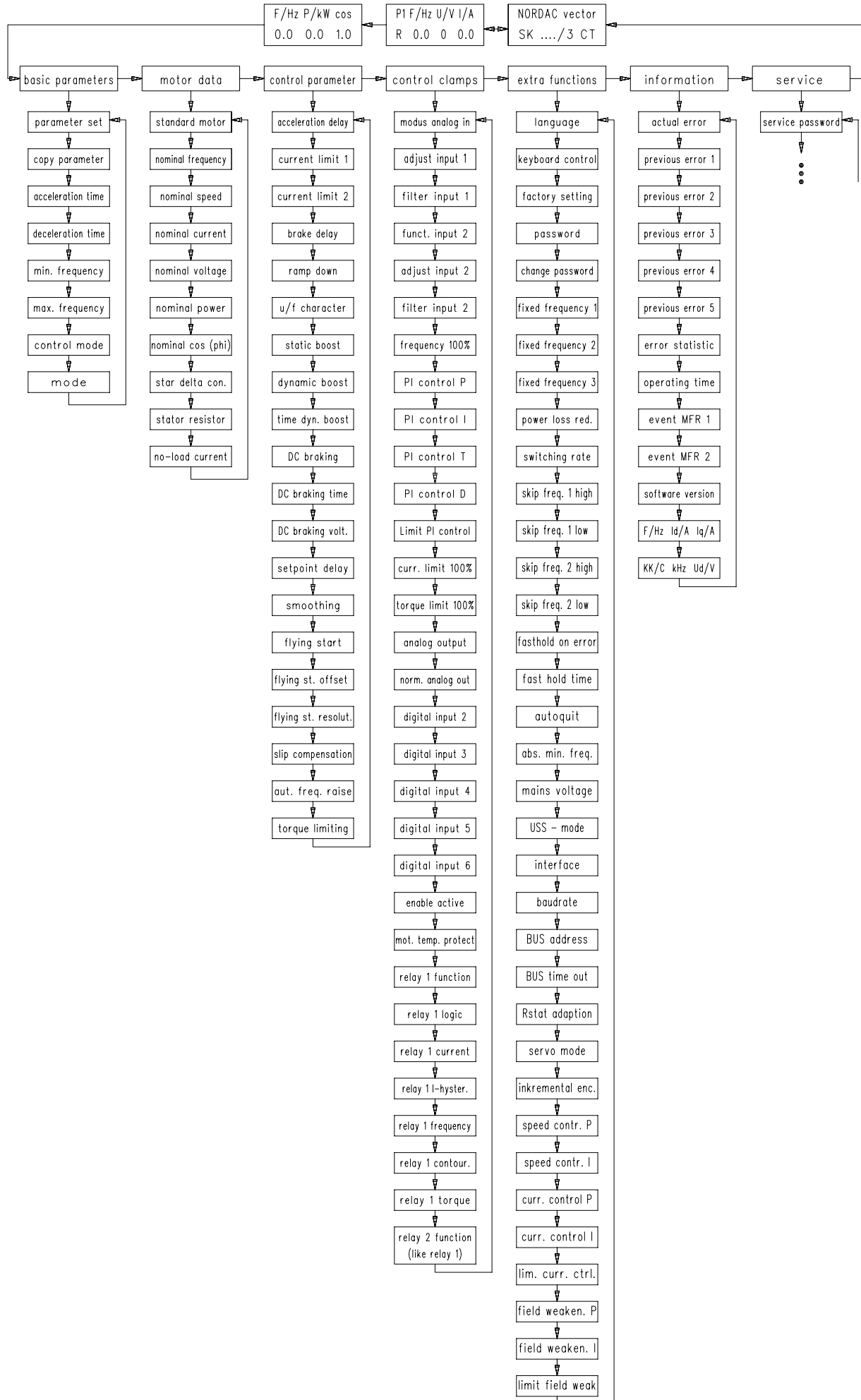

7.1 Menu items in tables

Individual menu items can be dealt with by selecting the menu group and by pressing the Enter key. If both field keys are operated at the same time, the display will return to the menu group ring structure and the operating value display.

Moving from one menu group to another is done using the field keys. To quit the ring structure of the menu groups the field keys are pressed simultaneously. Values contained in any individual menu item are changed with the value keys and saved with the Enter key.

In the "Type" table columns, menu items allowing for on-line changes are marked with an "O", while menu items correlated with parameter sets are marked with a "P".

Viewing of the menu items contained in shaded fields is dependent on certain configurations. For instance the v/f corner frequency can be viewed only on the condition that the linear or square characteristic has been selected in the control mode.

7.1.1 Basic parameters

Type	Function Comment	„Display indicates:“	Range of values Resolution	Default setting															
O	Manipulated parameter set Up to 4 parameter sets can be programmed, and then activated via corresponding control inputs.	„Parameter set“	1 ... 4	1															
	This parameter selects one of the 4 possible parameter sets which can be used to control various motors in succession. In that way each of the motors can be operated fully exploiting its particular capacities under optimum operating conditions. Hardly any waiting time is required when switching over to another parameter set.		<table border="1"> <thead> <tr> <th>Control terminals</th> <th>Parameter input 1</th> <th>Parameter input 2</th> </tr> </thead> <tbody> <tr> <td>parameter set 1</td> <td></td> <td></td> </tr> <tr> <td>parameter set 2</td> <td>X</td> <td></td> </tr> <tr> <td>parameter set 3</td> <td></td> <td>X</td> </tr> <tr> <td>parameter set 4</td> <td>X</td> <td>X</td> </tr> </tbody> </table>	Control terminals	Parameter input 1	Parameter input 2	parameter set 1			parameter set 2	X		parameter set 3		X	parameter set 4	X	X	
Control terminals	Parameter input 1	Parameter input 2																	
parameter set 1																			
parameter set 2	X																		
parameter set 3		X																	
parameter set 4	X	X																	
	Copy parameter set Complete parameter sets can be copied.	„Copy param.“	1 ... 4, except parameter set currently being manipulated	2 → 1															
PO	Acceleration time is the time from 0Hz to the set maximum frequency. The inverter will accelerate the frequency up to the preset value following a linear ramp.	„Acceleration time“	0.05 ... 1600s 0.00 ... 1600s -only with linear characteristic curve 0.05s	*															
PO	Deceleration time is the time needed to reduce the set max. frequency to 0Hz in accordance with a linear ramp.	„Deceleration time“	0.05 ... 1600s 0.00 ... 1600s -only with linear characteristic curve 0.05s	*															
PO	Minimum output frequency only <u>without</u> selecting ±10V for the setpoint input, otherwise fixed at 0Hz and not visible. ...is the frequency which is supplied by the inverter when the minimum setpoint is applied (corresponding to alignment 1/2: 0% in the control terminals group). This setpoint can be e.g. 0V, 0mA or 4mA.	„Minimum freq.“	0 ... maximum frequency 0.1Hz	0.0Hz															

Type	Function Comment	„Display indicates:“	Range of values Resolution	Default setting
PO	Maximum output frequency	„Maximum freq.“	minimum frequency ... 999Hz 0.1Hz	70.0Hz
	is the frequency which is supplied by the inverter when the maximum setpoint is applied (corresponding to balancing 1: 100% in the control terminals group.) This setpoint can be 10V or 20mA for example. By setting the servo mode to „ON“ the possible maximum frequency is limited to twice the set rated motor frequency (motor data).			
P	Control mode	„Control mode“	-linear characteristic curve -square characteristic curve -automatic characteristic curve -ISD control	ISD control
	<p>Suitable for multi-motor drive or synchronous motors !</p> <p><u>linear</u>: Constant ratio between voltage and frequency up to the nominal working point. The starting torque is determined via the static and the dynamic boost.</p> <p><u>square</u>: Suitable for a square load torque, as e.g. in fan drives or pumps.</p> <p>Suitable for <u>one</u> three-phase asynchronous motor connected to <u>one</u> inverter !</p> <p><u>automatic</u>: The inverter calculates a linear output characteristic on the basis of the motor data which is suitable for simple applications only.</p> <p><u>ISD regulation</u>: The magnetic motor flux is constantly kept at the nominal value. This function is not suitable for multi-motor operation or synchronous motors.</p>			<p style="text-align: center;">U/f character</p>
	Mode	„Mode“	analog / motor potentiom.	analog
Selection of this parameter is associated with a number of different factory settings regarding the digital control inputs and and the analog setpoint input (cf. item 7.2.1 Mode).				

7.1.2 Motor data

Factory settings regarding these data refer to a 4-pole three-phase a.c. standard motor with rated inverter output. These data will not be displayed unless either ISD control or the automatic characteristic curve has been selected (except for the "standard motor" information).

Type	Function Comment	„Display indicates:“	Range of values Resolution	Default setting
P	Standard motor	„standard motor“	0.37kW...P _{NFU} + one frame size values of the 4-pole three-phase standard motors	P _{NFU} *
	Even a „No motor“ setting can be made! With that the biasing period of the current controller is set to zero. Applicable only if the "linear characteristic" control mode has been selected.			
P	Nominal frequency	„nominal freq.“	0 ... 999.0Hz 1Hz	50Hz

Type	Function Comment	„Display indicates:“	Range of values Resolution	Default setting
P	Nominal speed	„nominal speed“	0 ... 30.000min-1 1min-1	*
P	Nominal current	„nominal current“	0 ... 1.5 · I _{NFU} 0.1A	*
P	Nominal voltage	„nominal voltage“	0 ... 460V 1V	400V
P	Nominal power	„nominal power“	0 ... 1.5 · P _{NFU} 0.01kW	P _{NFU} *
P	cos φ	„nominal cos (PHI)“	0.5 ... 1.0 0.01	*
P	Running connection <u>Be absolutely sure</u> to set this menu item correctly before activating automatic calculation of the stator resistance, because if the setting is not right, the result of stator resistance calculation won't be either and may cause overcurrent disconnection.	„running connect.“	star / delta	
P	Stator resistance 0 = automatic calculation after the Enter key has been pressed. Ensure correct setting of the motor's running connection. The resistance stored will be that of one phase winding.	„stator resistance“	0 ... 40Ω, depending on motor data 0.01Ω	*
P	No-load motor current This value is automatically calculated from the other motor data. If the cos φ or the rated motor current is changed, the no-load current will be different too. For no-load current calculation the motor should be operated at a frequency a little lower than the rated frequency (e.g. 45Hz). Read the result in the operating data display.	„no-load current“	0 ... I _{NMOT} 0.1A	*

7.1.3 Control parameters

Type	Function Comment	„Display indicates:“	Range of values Resolution	Default setting
PO	Acceleration delay	"accel. delay"	OFF / ON	ON
	<p>This function enables the drive to be accelerated without pushing the inverter current to a peak value.</p> <p>Two different current limits can be set. The <u>1st current limit</u> prevents the output frequency from rising any further while the acceleration time is extended.</p> <p>The <u>2nd current limit</u> causes the output frequency to decrease. If the load is too high, the desired frequency may not be reached.</p> <p>This function is <u>not available</u> when the servo mode has been selected (ON, speed control).</p>			

Type	Function Comment	„Display indicates:“	Range of values Resolution	Default setting
PO	Current limit 1 for the acceleration delay Only <u>with</u> acceleration delay ON A further frequency increase is prevented.	„current limit 1“	0 ... current limit 2 0.1A	$1.4 \cdot I_{NFI}$
PO	Current limit 2 for the acceleration delay Only <u>with</u> acceleration delay ON The output frequency is reduced.	„current limit 2“	current limit 1 ... $1.5 \cdot I_{NFI}$ 0.1A	$1.5 \cdot I_{NFI}$
PO	Braking delay With this function the electrical load on the required brake resistor is reduced (energy recovery from the motor!). The motor is decelerated within the set braking period. When the d.c. link voltage reaches the switching threshold of the braking delay value, the inverter interrupts the braking action. As soon as the d.c. link voltage drops again, deceleration of the motor goes on. This function is applicable to the "normal" braking ramp and to quick braking. A braking resistor will be required! Caution! This mode is not suitable for lifting gear applications.	„brake delay“	OFF / ON	OFF
PO	Ramp down OFF: At controller disable, the motor is <u>not</u> decelerated in accordance with a reference setpoint, instead the inverter switches off the final stage → the motor runs down. ON: The inverter uses the set deceleration ramp to arrest the motor.	„ramp down“	OFF / ON	ON
PO	Corner frequency Only <u>with</u> linear or square characteristic curve (cf. item 7.1.1 Control mode; basic parameters) Having reached this frequency the inverter supplies the maximum possible output voltage. This value is equal to the mains voltage.	„corner frequ.“	20 ... 999Hz 0.1Hz	50Hz
PO	Static boost Only <u>with</u> linear or square characteristic curve (cf. item 7.1.1 Control mode; basic parameters) In the lower range of the v/f-characteristic curve the voltage is boosted to provide the motor with a higher starting torque. Setting too high a boost value can lead to overcurrent. $f_n = v/f$ corner frequency	„static boost“	OFF ... 100V 0.1V	*
PO	Dynamic boost Only <u>with</u> linear or square characteristic curve Voltage boosting for a limited period of time, otherwise like the static boost. Is added to the static boost. Used to enable breakaway of a drive.	„dynamic boost“	OFF ... 120V 0.1V	OFF
PO	Dynamic boost period Only <u>with</u> linear or square characteristic curve and <u>with</u> dynamic boost. Period of time for which the added dynamic boost will be effective. Only after controller has been enabled.	„dyn. boost period“	0.1 ... 20.0s 0.1s	0.1s

Type	Function Comment	„Display indicates:“	Range of values Resolution	Default setting
PO	DC braking only <u>with</u> ramp down <u>ON</u>	„dc braking“	OFF / ON / Immediately	OFF
	<p>With this function a direct voltage can be fed to the motor instead of a frequency. Along with a torque at the motor shaft a counter-torque is set up. Do not use this function as a substitute for a mechanical brake.</p> <p>ON: When frequency drops below the absolute minimum (1.0Hz) the inverter changes from frequency to direct current supply.</p> <p>Immediately: When the controller enable is switched off, the inverter <u>immediately</u> changes from frequency to direct voltage. This setting will work no matter how great output frequency is at that moment.</p> <p>With direct current braking, no exact prediction of stopping time is possible, and no braking energy will be recovered from the motor either. Braking energy is converted to heat in the rotor of the motor.</p>			
PO	DC braking period only <u>with</u> DC-brake ON or Immediately	„dc braking period“	0.1 ... 60.0s 0.1s	1.0s
	<p>DC brake ON: The DC braking function is associated with a time limit.</p> <p>DC brake immediately: Depending on the setpoint currently applicable (output frequency), braking will take all or only part of the time.</p> <p>If controller enable is switched on again before this period is over, the inverter interrupts dc braking and starts again in accordance with the setpoint.</p>			
PO	DC brake direct voltage only with DC-brake ON or Immediately	„dc brake voltage“	0 ... 120V 0.1V	*
	The value set for the direct voltage will affect current intensity during braking.			
PO	Setpoint delay Function controlling an electromagnetic brake.	„setpoint delay“	OFF ... 10s 0.05s	OFF
	<p>Reaching the <u>absolute minimum frequency</u> value (1.0Hz) set before, the frequency inverter interrupts the frequency increase/decrease for the adjusted delay period. As a result there is time enough for the multifunction relay 2 (MFR 2, control terminals) to ensure that brake control will cause the mechanical brake either to be lifted or to take hold.</p> <p>The effect of this function is to prevent the motor from starting up against a brake while it is locked or, especially in hoisting gear drives ($f_{abs.min} \geq 2.0$ Hz), to prevent sagging of the load as a result of sudden stopping.</p>			
PO	Smoothing e.g. to ensure S shape of setpoint frequency curve	„ramp smooth.“	OFF... 100% 1%, OFF ...10% will have no effect!	OFF
	<p>Whereas normally the rise or reduction of frequency, as the case may be, is linear all through the defined period of ramping up (or down), a very smooth transition from a static state to acceleration or deceleration (without jerking) is achieved using the ramp smoothing function.</p> <p>Likewise the acceleration or deceleration rate is slowly reduced towards reaching the final speed. The overall time required for acceleration and deceleration is extended by about the set smoothing period.</p> <p>The graph on the right shows acceleration set to 10s and smoothing to 50% which means that a 5s interval is allotted to the smoothing process. Acceleration will therefore take 15 seconds in all.</p> <p>This function is ineffective with ramps greater than 1000Hz/s or smaller than 1Hz/s.</p>			

Type	Function Comment	„Display indicates:“	Range of values Resolution	Default setting
P	Flying start e.g. for fan drives	„flying start“	OFF ON (R+L) After disconnect. (R+L) ON (R/L) After disconnect. (R/L)	OFF
	<p>This is a special feature ensuring that the frequency inverter will measure the frequency of the rotating field in a running motor before starting to control its speed at exactly the measured frequency. Only then will it accelerate the motor up to the preset setpoint, also taking into account the sense of rotation of the motor.</p> <p>Selection of the ON option ensures that the frequency searching function is activated each time the inverter is re-enabled. If the search function is initiated while the motor is at rest and in a no-load condition, the motor may react with a slight movement.</p> <p>For the search function to be executed within the „after disconnection“ option, disconnection must <u>not</u> have been preceded by a braking ramp, e.g. after a fault message reset or with ramp down = OFF.</p> <p>R+L: The frequency inverter will scan the frequencies in either sense of rotation.</p> <p>R/L: The frequency inverter will scan the frequencies only in the sense of rotation defined via the digital input.</p>			
O	Flying start offset only <u>with</u> flying start ON or after disconnection This adjustable offset is added to the frequency determined by the flying start function.	„flying start offset“	- 30Hz ... + 30Hz 0.1Hz	7.0Hz
	<p>Experimental runs have shown that offsets between 2 and 4Hz are most favourable for high outputs ($\geq 37\text{kW}$). We recommend programming the acceleration delay to „ON“.</p> <p>Too high an offset value will result in the inverter current quickly reaching the limit. If it is set too low, overvoltage or chopper operation will occur.</p>			
O	Flying start resolution only <u>with</u> flying start ON or after disconnection The resolution for searching the frequency range is adjustable.	„flying st. resolution“	0.05 ... 5.00Hz 0.05Hz	0.40Hz
	<p>Adjusting a finer resolution (smaller setting or increment) will prolong searching time.</p>			
PO	Slip compensation only <u>with</u> automatic characteristic curve or ISD control	„slip compensat.“	OFF / ON	ON
	<p>The frequency inverter tries to maintain speed approximately constant by correcting the frequency. This function is dependent on the load current.</p>			
PO	Automatic raising of frequency prevents excessive heating of the brake resistor during energy recovery (braking mode)	„auto. freq.raising“	OFF / ON	OFF
	<p>Supersynchronous (regenerative) operation of a three-phase motor will result in an overvoltage disconnection by the inverter. This can be avoided by connecting a braking resistor to the terminals provided for that purpose. Due to the energy fed back to the loop, the resistor tends to grow hot. To prevent excessive heating (as sometimes happens where crank gear is involved), the inverter is able to raise the output frequency, the set maximum frequency (basic parameters) representing the upper limit. The frequency change follows the adjusted acceleration and deceleration ramps (basic parameters).</p> <p>As voltage is bound to rise very fast in the intermediate circuit of the inverter for physical reasons, to connect a braking resistor to the inverter is a necessity.</p> <p>If the controller is disabled, the inverter will reduce the frequency within the set braking period!</p> <p>Caution! This operating mode is <u>not suitable</u> for lifting gear functions.</p> <p>In <u>crank gears</u> propulsive and regenerative loads affecting the drive are produced in every cycle, resulting in frequent braking chopper operation.</p>			

Type	Function Comment	„Display indicates:“	Range of values Resolution	Default setting
	Proportionality factor for automatic frequency raising Only <u>with</u> automatic frequency raising set to "ON" For automatic frequency raising to be controlled in a dynamic fashion in accordance with load requirements. Response will set in fast with higher settings and more slowly with low setting values.	"P fact.freq.raising"	0 ... 32766 1	1000
PO	Torque limiting related to the nominal motor torque only <u>with</u> automatic characteristic curve or ISD control	"torque limit"	OFF, 25 ... 400% 1%	OFF
	If the drive is operated in the servo mode on a speed control basis, a pre-programmed torque limit equivalent to 100 % of the rated motor torque is automatically activated. The "OFF" reading in the display will be replaced by Mn[100%] .			

7.1.4 Control terminals

Type	Function Comment	„Display indicates:“	Range of values Resolution	Default setting
	Mode analog setpoint input 1 $\pm 10V$ only <u>without</u> programming a digital input to "enable left" or "direction of rotation". If $\pm 10V$ is selected, the minimum frequency is always set to 0Hz. If "4...20mA" has been selected, the inverter is disabled automatically (no output signal) should values decrease below 2mA.	"mode an. inp.1"	0 ... 10V limited 0 ...10V -10V ... +10V 0 ... 20mA 4 ... 20mA OFF	0 ... 10V limited
	Aligning the analog setpoint input 1: 0% Voltage or current value applied being stored as 0% value = minimum frequency. The difference between alignment 0% and alignment 100% must be > 3,5V (>14mA).	"alignm. 1 : 0% →"	-	0V or 0mA
	Aligning the analog setpoint input 1: 100% Voltage or current value applied being stored as 100% value = maximum frequency. The difference between the 0% aligned value and the 100% aligned value must be > 3.5V (>14mA).	"alignm. 1 : 100% →"	-	10V or 20mA
O	Extra filter in setpoint input 1 Low-pass filter against voltage peaks, response time is extended.	"filter an.input 1"	OFF / ON	OFF

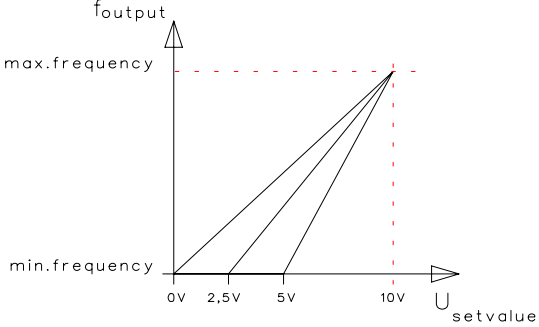
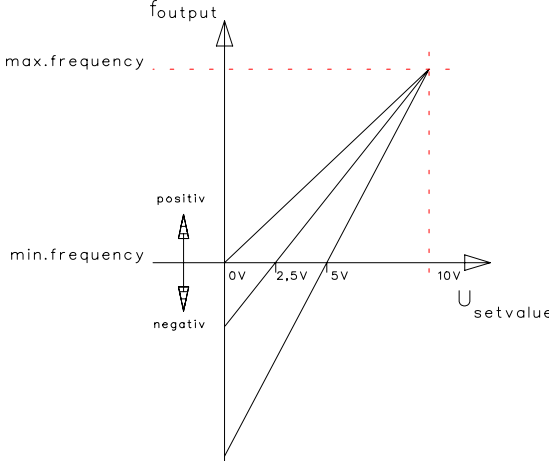
Type	Function „Display indicates:“ Comment	Range of values Resolution	Default setting
	<p><u>Aligning the analog inputs</u></p> <p>Aligning inputs 1 and 2 as described above permits adjustment of the frequency inverter to any setpoint which is commonly used.</p> <p><u>E.g. 0 ... 10V limited :</u></p> <p>When the current drops below the setpoint aligned to 0%, the adjusted minimum frequency is supplied.</p> <p>This function is generally applicable to current setpoints (0/4...20mA).</p>	<p><u>E.g. 0 ... 10V :</u></p> <p>The diagrams show that a change of rotation can be brought about using 0...10V, with standstill e.g. when a potentiometer is in centre position (5V).</p>	
			
	<p>PLEASE NOTE: If voltage exceeds the setpoint aligned to 100% (e.g. 9.3V instead of 10V) does <u>not</u> mean that the set max. frequency is exceeded too.</p>		
P	<p>Function of the analog setpoint input 2 „funct. anal. input 2“</p> <p><u>Actual frequency value</u> or <u>PID controller</u> is intended for analog speed control, cf. item 7.1.5 Extra functions, and item 7.2.5 Speed controller.</p> <p>**only with "posicon" option</p>	<p>None addition to input 1 subtraction from input 1 actual frequency value current limit torque limit *** PID controller Positioning at maximum frequency**</p>	None
	<p>*** A torque limit <u>cannot</u> be set <u>unless</u> either the ISD or the automatic control mode has been selected (cf. 7.1.1. Basic parameters)</p> <p>Never set a torque limit < 20%, because this could result in erratic behaviour of the drive!</p>		
	<p>Mode analog setpoint input 2 "Mode an. input 2"</p> <p>± 10V only <u>without</u> programming a digital input to "enable left" or "sense of rotation".</p> <p>Selection of ± 10V always results in the minimum frequency being set to 0Hz.</p> <p>When "4...20mA" is selected, the inverter is disabled automatically should values decrease below 2mA (there will be no output signal).</p>	<p>0 ... 10V limited 0 ... 10V -10V ... +10V 0 ... 20mA 4 ... 20mA</p>	0 ... 10V limited

Type	Function Comment	„Display indicates:“ Range of values Resolution	Default setting
P	Aligning the analog setpoint input 2: 0% „alignm. 2: 0% →“ Voltage or current value applied being stored as 0% value = min. frequency. The difference between 0% aligned value and 100% aligned value must be > 3,5V (> 14mA). Only <u>with</u> a function selection for input 2	-	0V or 0mA
P	Aligning setpoint input 2: 100% „alignm. 2: 100% →→“ Voltage or current value applied stored as 100% value = max. frequency. The difference between 0% aligned value and 100% aligned value must be > 3,5V (> 14mA). Only <u>with</u> a function selection for input 2.	-	10V or 20mA
	Extra filter in setpoint input 2 „filter an.input 2“ Low-pass filter against voltage peaks, the response time is extended.	OFF / ON	OFF
PO	Frequency limit for value aligned to 100%, input 2 „frequency 100%“ only <u>with</u> one of the functions for analog input 2: <ul style="list-style-type: none"> • addition • subtraction • actual frequency value • PID controller • maximum frequency during positioning 	0 ... 999 Hz 1 Hz	50 Hz
PO	P component of PI/PID controller „PI controller P“ only <u>with</u> the function actual frequency value or PID controller related to the differential frequency in Hz	0 ... 800% 1%	100%
PO	I component of PI/PID controller „PI controller I“ only <u>with</u> the function actual frequency value or PID controller as 1/time constant, like P component	0 ... 100%/ms 0.1%/ms	10%/ms
PO	T component of PI controller „PI controller T“ only <u>with</u> the function actual frequency value	2 ... 32000ms 1ms	2ms
PO	D component of PI controller „PI controller D“ only <u>with</u> the PID controller function as time constant	0 ... 400%/ms 0.1%/ms	0%/ms
PO	Value of maximum frequency sweep „limit PI controller“ only <u>with</u> function actual frequency value or PID controller	2 ... 999Hz 0.1Hz	10 Hz
PO	Current limit for 100% alignment, input 2 „current limit 100%“ only <u>with</u> the function current limit	0 ... $2 \cdot I_{NFI}$ 0.1A	$1,5 \cdot I_{NFI}$

Type	Function Comment	„Display indicates:“ Range of values Resolution	Default setting
PO	Torque limit for 100% alignment, input 2 „torque 100%“ related to the nominal motor torque only <u>with</u> the torque limit function	10 ... 400% 1%	100%
O	Programming of the analog output „analog output“ ***Setting a torque limit <u>presupposes</u> selection of the ISD or the automatic control mode. Sign: The analog output allows for quantities positive or negative in sign, with - 0V to 5 V corresponding to negative values, e.g. -100%** to 0% and - 5V to 10V corresponding to positive values, 0% to 100%** **The 100% value varies with normalization of the analogue output.	OFF output frequency output frequency with sign output current output voltage active power cos φ torque*** torque*** with sign speed speed with sign	OFF
O	Maximum value of the analog output „norm. analog output“ The %-value indicated corresponds to 10 V of output voltage only <u>with</u> a function of the analog output For a linear or square characteristic, the output frequency value is related to the set corner frequency (control parameters).	10% ... 500% of nominal value of the motor output 1%	100%
	Programming of digital input 2 „digital input 2“ Representation of the permissible function. ***depends on the „Mode“ selected in Basic parameters (cf. item 7.1.1/7.2.1 Mode)	***	*** Enable left
	Programming of digital input 3 „digital input 3“ Representation of the permissible function. ***depends on the „Mode“ selected in Basic parameters (comp. item 7.1.1/7.2.1 Mode)	***	*** Fixed frequency 1
	Programming of digital input 4 „digital input 4“ Representation of the permissible function. ***depends on the „Mode“ selected in Basic parameters (comp. item 7.1.1/7.1.2 Mode)	***	*** Parameter input 1
	Programming of digital input 5 „digital input 5“ Representation of the permissible function. ***depends on the „Mode“ selected in Basic parameters (comp. item 7.1.1/7.1.2 Mode)	***	*** Parameter input 2

Type	Function Comment	„Display indicates:“ Range of values Resolution	Default setting
	Programming of digital input 6 „digital input 6“ Representation of the permissible function. ***depends on the „Mode“ selected in Basic parameters (comp. item 7.1.1/7.1.2 Mode)	***	*** Fault acknowledgement
	Function of controller enable „enable active“ "Level" can be used for automatic restarting after switching on the mains	Edge / Level	Edge
O	Motor PTC resistor „mot. temp. prot.“ Monitoring the motor temperature with PTC resistors or thermostats.	OFF / ON	OFF
PO	Programming of the multifunction relay 1 „relay 1 function“ Errors will always trip the relay. Clear text representation. Acceleration delay only <u>with</u> acceleration delay = ON Contouring error only <u>with</u> speed controlling, cf. 7.1.5 Extra functions and 7.2.5 Speed controller Torque limit only <u>with</u> ISD control or automatic characteristic curve, choosing between powered or regenerative operation.	Current limit (C) Frequency limit (F) Brake control (B) Temperature warning (T) Overcurrent (O) Acceleration delay (A) Contouring error Slippage (S) Torque limit (T) Torque limit, regen. (T) Setpoint reached (The letters in brackets appear in the information parameters when the event they stand for has triggered the multifunction relay, cf. item 7.1.6.)	Error
<p>Although basically the multifunction relay 1 is permanently programmed for fault signalling, other functions can be assigned to it as well. The contact opens as soon as an error occurs or a programmed limit value is reached. When the contact is closed (ready for operation!), the relay is in rest position.</p> <p>Page through the available functions with the <i>left</i> value key (ascending values) and switch to ON or OFF with the <i>right</i> value key (descending values). Any change must be validated with the Enter key.</p> <p>If a number of functions have been selected there is a choice as to whether the conditional statements should be linked with AND or with OR .</p> <p>If a relay has been programmed to perform various functions, the function that has triggered the relay at a particular event can be read out in the information parameters.</p> <p><u>Brake control:</u> When the frequency value has decreased to the absolute minimum (cf. 7.1.5 Extra functions), the relay contact closes, when it continues to drop, the contact opens. Although the fault signal is still active then (applies to relay 1 only), it is no longer relevant after the frequency has dropped below the absolute minimum value.</p> <p><u>Temperature warning:</u> When the first temperature limit in the inverter is reached or the PTC resistor on the motor has triggered, the inverter reacts with a warning signal which is not followed by a disconnection yet. Only when the second temperature limit has been reached or by the end of a 30 second period of motor overtemperature will the inverter be disconnected.</p> <p><u>Overcurrent:</u> This warning indicates that the inverter's overcurrent range has been reached. Depending on the current intensity, this condition will be tolerated only briefly or for some time even. By the end of the permissible time the inverter is disconnected (Cf. item 9.2).</p> <p><u>Regenerative operation:</u> The MFR signals regenerative operation, i.e. energy is being fed back by the motor. This means that the torque will be negative.</p>			

Type	Function Comment	„Display indicates:“ Resolution	Range of values	Default setting
PO	Logical operators for the additional conditions for MFR 1 „Relay 1 logic“ only <u>with</u> more than one function programmed		AND/OR	OR
PO	Current limit MFR1 „relay 1 current“ only if relay is programmed to respond to a current limit		0 ... $2 \cdot I_{NFI}$ 0.1A	I_{NFI}
PO	Hysteresis current limit MFR1 „relay 1 I-hyst.“ only if programmed to respond to a current limit difference between operate point and release point of relay (indication of current)		0 ... 20% 1%	10%
PO	Frequency limit MFR1 „relay 1 freq.“ only if programmed to respond to frequency limit		0 ... maximum frequency 0.1Hz	50.5Hz
PO	Maximum contouring error MFR1 „relay 1 contour.“ only if programmed to respond to contouring errors		0 ... 500min^{-1} 1min^{-1}	100min^{-1}
PO	Torque limit MFR1 „relay 1 torque“ only if programmed to respond to torque limit		0 ... 400% 1%	300%
PO	Programming of the multifunction relay 2 „relay 2 fct.“ Represented in clear text Acceleration delay only <u>with</u> acceleration delay = ON (control parameters) Contouring error only <u>with</u> servo mode ON, cf. 7.1.5 Extra functions and 7.2.5 Speed controller Torque limit only <u>with</u> ISD control or automatic characteristic curve; with alternatives powered or generative operation		Current limit (C) Frequency limit (F) Brake control (B) Temperature warning (T) Overcurrent (O) Acceleration delay (A) Contouring error Slip (S) Torque limit (T) Torque limit, regen. (T) Setpoint reached (S) Inactive error (I)	Brake contr.
	<p>Mode of operation same as MFR 1, but without the permanently programmed fault signalling function.</p> <p><u>Inactive error</u>: An error which led to disconnection of the inverter does not exist any more. The stored fault message can be reset, and then the drive is ready for operation again.</p> <p><u>Setpoint reached ($f \geq = f_{s:}$)</u>: indicates that the output frequency being currently supplied is \geq the adjusted setpoint.</p> <p>If a relay is programmed to perform several functions the function that made the relay trip can be read out in the information parameters (represented by the letters in brackets).</p>			
PO	Logical operators for the conditions for MFR2 „relay 2 logic“ only <u>with</u> more than one function programmed		AND/OR	OR
PO	Current limit MFR2 „relay 2 current“ only if programmed to respond to current limit		0 ... $2 \cdot I_{NFI}$ 0.1A	I_{NFI}
PO	Hysteresis current limit MFR2 „relay 2 I-hyst.“ only if programmed to respond to current limit Difference between operate point and release point of relay (indication of current)		0 ... 20% 1%	10%

Type	Function Comment	„Display indicates:“	Range of values Resolution	Default setting
PO	Frequency limit MFR2 only if programmed to respond to frequency limit	„relay 2 freq.“	0 ... maximum frequency 0.1Hz	50.5Hz
PO	maximum contouring error MFR2 only if programmed to respond to contouring errors	„relay 2 contour.“	0 ... 500min ⁻¹ 1min ⁻¹	100min ⁻¹
PO	Torque limit MFR2 only if programmed to respond to torque limit	„relay 2 torque“	0 ... 400% 1%	300%

7.1.5 Extra functions

Type	Function Comments	„Display indicates:“	Range of values Resolution	Default setting
O	Language	„language“	German English French Spanish Swedish Dutch	German
O	Keyboard control With this function the inverter can be controlled via the integrated keyboard. <i>Value keys:</i> will change the setpoint, also towards negative values <i>Enter-key:</i> start / stop By activating keyboard control (ON) all control functions executed via the control terminal strip are disabled (cf. item 7.2.2 Keyboard control).	„keyboard control“	OFF / ON	OFF
	Loading the default setting Change to the display “ENTER” Use the Enter key to initiate loading.	„factory setting“	--- ENTER	---
	Password protects the inverter settings from being changed by unauthorized persons With the "password" function all of the parameters can be made invisible (by entering a password different from the one selected in the "change password" parameter). Parameters exclusively providing information, such as operating data or error messages, are still read out however.	„password“	0 ... 9999 1	0
	Changing the password	„change password“	0 ... 9999 1	0
PO	Fixed frequency 1 only <u>with</u> „analog“ mode (cf. item 7.2.3 Fixed frequencies)	„fixed frequency 1“	± maximum frequency 0.1Hz	10.0Hz
PO	Fixed frequency 2 only <u>with</u> „analog“ mode (cf. item 7.2.3 Fixed frequencies)	„fixed frequency 2“	± maximum frequency 0.1Hz	20.0Hz
PO	Fixed frequency 3 only <u>with</u> „analog“ mode (comp. item 7.2.3 Fixed frequencies)	„fixed frequency 3“	± maximum frequency 0.1Hz	40.0Hz

Type	Function Comments	„Display indicates:“	Range of values Resolution	Default setting
PO	Loss power reduction only <u>without</u> servo mode („Extra functions“)	„loss reduction“	OFF/ON	OFF
	<p>By activating this function the overcurrent limit of the inverter is reduced when a thermal limit is reached.</p> <p>This function is intended to ensure that disconnection of the inverter because of overtemperature is delayed as far as possible or even prevented altogether.</p>			
PO	Pulse frequency	„switching frequ.“	2kHz / 4kHz / 8kHz / 16kHz*	8kHz
	<p>With a pulse frequency of 16kHz, thermal load on the inverter has got to be reduced. This can be achieved through intermittent operation or by keeping ambient temperature below the admissible level, or by avoiding full utilization of the admissible inverter current.</p> <p>When the inverter reaches a <u>thermal limit value</u>, control reduces the pulse frequency automatically, to as low a value as 2kHz if necessary. As a consequence the switching losses are diminished and inverter heating is limited or reduced.</p> <p>After the temperature has dropped below the limit value, the system goes back to the initial pulse frequency.</p> <p>*) Only devices up to 37kW allow for a 16kHz setting!</p>			
PO	Skip frequency 1 upper limit 0 = OFF	„skip 1 uplim“	lower limit 1 ... max. frequency 0.1Hz	OFF
PO	Skip frequency 1 lower limit 0 = OFF only <u>with</u> upper limit 1 ≥ 0,1Hz	„skip 1 lowlim“	upper limit 2 ... upper limit 1 0.1Hz	OFF
	<p>Between the upper and lower limit no static frequency value can be set. Frequency traverses this predefined range only during acceleration or deceleration periods.</p> <p>Any setpoint equivalent to a frequency between these limit values would result in the output frequency being increased or decreased.</p>			
PO	Skip frequency 2 upper limit 0 = OFF only <u>with</u> adjustment of upper limit 1	„skip 2 uplim“	lower limit 2 ... lower limit 1 0.1Hz	OFF
PO	Skip frequency 2 lower limit 0 = OFF only <u>with</u> upper limit 2 ≥ 0,1 Hz	„skip 2 lowlim“	0.1 ... upper limit 2 0.1Hz	OFF
P	Quick stop at fault	„quick stop fault“	OFF / ON	OFF
P	Quick stop time for quick stopping at a fault and quick stopping via a digital input	„quick stop time“	0.05 ... 10s 0.05s	0.1s

Type	Function Comments	„Display indicates:“	Range of values Resolution	Default setting
	<p>As soon as the frequency inverter detects either a malfunction which would bring on disconnection before long, or a mains failure, or receives the quick stop function signal (digital input), it begins to decelerate the motor until it stops. For this action the inverter may require the kinetic energy of the drive which is recovered to the d.c. link in the course of regenerative operation.</p> <p>Therefore execution of this function will depend on the respective driving application and on the operating conditions prevailing at the time.</p> <p>"Quick stop time" offers alternatives for setting the time in seconds during which the output frequency is to be reduced by 50Hz.</p> <p>This function only works in fault situations in which it is safe to let inverter operation go on for a short time! (Cf. Item 9.3 Quick stopping at faults)</p>			
	Automatic acknowledgement Number of acknowledgements	"autom. ack."	OFF, 1 ... 9, always (n · ack)	OFF
	<p>The inverter automatically acknowledges faults in the number set above, provided that the cause of the fault has been eliminated. Acknowledgements are executed after a delay of 10 seconds.</p> <p>Following a disconnection from the mains or a manual fault acknowledgement with the Enter key, the counter (value in brackets, max. 255) is reset to zero. After that the total number of acknowledgements is available again.</p>			
O	Absolute minimum frequency This menu item defines the lowest frequency the inverter is able to supply.	„abs. min. frequ.“	0.1 ... 10.0Hz 0.1Hz	1.0Hz
	<p>No output signal is supplied between 0 and the value set.</p> <p>The value selected in this item is also decisive of the frequency at which the setpoint delay (cf. item 7.1.3 Control parameters) begins to be active. In hoisting gear brake control applications, the absolute minimum frequency must be set to at least 2.0Hz => only then optimum effectivity of ISD control will be achieved.</p>			
	Mains voltage This parameter allows for a fixed setting of the maximum line voltage to be applied to the inverter. "Auto" → voltage is measured once right before the inverter signals readiness for operation.	„mains voltage“	Auto, 304 ... 506V 1V	Auto
	<p>Where major line voltage fluctuations are expected and where functions depending on line voltage are involved (such as braking chopper, braking delay or automatic frequency raising) a permanent setting should be adopted. For the inverter to yield optimum performance, a value as near to the optimum as possible should be established for this setting.</p>			
	USS mode	„USS mode“	Slave Master2	Master1 Master2 Slave
	<p><u>Slave</u>: The inverter works as USS slave and can be controlled and parameterised.</p> <p>A "Master function" is selected whenever one inverter which is provided with an operating unit controls other inverters without operating unit. The recommended baud rate is 38400 baud. The slave to be controlled is selected via the „BUS address“ (cf. item 7.2.4 USS mode).</p> <p><u>Master 1</u>: In this mode a slave can be remote-controlled via the keyboard and the control terminals of the master.</p> <p><u>Master 2</u>: All parameters of the master (slave address included) are transferred with the <u>Enter key</u> to a slave which is ready for operation.</p> <p><u>Master 3</u>: The control functions of the master inverter (digital inputs and analog setpoint) are transferred to the slave inverter(s).</p>			
P	Interface not with USS mode master 3	„interface“	local BUS BUS limited BUS limited + setpoint 2	setpoint 1 BUS BUS + setpoint 2 setpoint 1 limited

Type	Function Comments	„Display indicates:“ Resolution	Range of values	Default setting
	Local: Inverter is controlled via control terminal strip Setpoint 1 BUS: Only one setpoint is transferred over the bus. Evaluation as with analog setpoint input 1. The digital inputs of the control terminals continue to be active "locally". BUS: The inverter is controlled via the BUS (control word and setpoint 1). The analog setpoint input 2 continues to be active "locally". BUS + setpoint 2: As in "BUS", however with additionally a 2nd setpoint. It is evaluated in the same way as the analog setpoint input 2. Setpoint 1 limited: As in "Setpoint 1 BUS", however with setpoint 1 limited to 0 ... 100% (negative setpoints are illegal). BUS limited: As in "BUS", however with setpoint 1 limited to 0 ... 100% (negative setpoints are illegal). BUS limited + setpoint 2: As in "BUS + setpoint 2", however with setpoint 1 limited to 0 ... 100% (negative setpoints are illegal).			
	Baud rate Transmission rate via the BUS (RS 485 interface)	„Baud rate“	4800 / 9600 / 19200 / 38400 baud	9600 baud
	BUS address not with USS mode Master 3 USS mode = slave : own address USS mode = master 1/2 : address of the inverter being controlled	„BUS address“	0 ... 30 1	0
	Message down-time not with USS mode Master 2 0 = no monitoring	„BUS time out“	0 ... 100s 0.1s	0
PO	Cyclic stator resistance measurement "Rstat adaption" only <u>with</u> automatic or ISD control		OFF / ON	OFF
	The stator resistance of the connected motor (comp. item 7.1.2 Motor data) is measured periodically once every minute, though only if the inverter is not enabled. This function ensures that a change of the stator resistance due to an increase of motor temperature is compensated.			
P	Servo mode only <u>with</u> the incremental shaft encoder input option (cf. item 7.2.5 speed controller)	„servo mode“	OFF / ON (option) for motor speed control!	OFF
	Can be used only if the optional incremental shaft encoder input is provided permitting to transmit the actual speed value picked up by an incremental shaft encoder. PLEASE NOTE: 1. The "servo" mode will limit the maximum possible frequency (Basic parameters) to twice the rated motor frequency (Motor data) set. 2. The "servo" mode will automatically activate an internal torque limit equal to 100% (of the rated motor size). The internal torque limit can be varied due to the effect of the adjustable torque limit. 3. The rotating field of the incremental encoder must be in accordance with that of the motor. If this is not the case (e.g. in NORD motors with encoder HG 660), the tracks A+ and A- must be interchanged.			
	Shaft encoder number of increments "shaft enc. resol." only <u>with</u> optional incremental shaft encoder input		500 / 512 / 1000 / 1024 / 2000 / 2048 / 4096 / 5000 Pulses/revolution	4096
PO	P component of the speed controller "speed controller P" related to differential speed in min ⁻¹ only <u>with</u> servo mode = ON		0 ... 800% 1%	100%

Type	Function Comments	„Display indicates:“	Range of values Resolution	Default setting
PO	I component of the speed controller as 1/time constant, same as P component only <u>with</u> servo mode = ON	„speed controller I“	0 ... 800%/s 0.1%/s	10%/s
PO	P component of the current controller related to differential speed in min ⁻¹ only <u>with</u> servo mode = ON	„current contr. P“	0 ... 800% 1%	150%
PO	I component of the current controller as 1/time constant, as for P component only <u>with</u> servo mode = ON	„current contr. I“	0 ... 1000%/ms 0.1%/ms	30%/ms
PO	Maximum voltage change the current controller can effect only <u>with</u> servo mode = ON	„limit curr. contr.“	0 ... 400V 1V	100V
PO	P component of field weakening controller only <u>with</u> servo mode = ON	„field weaken. P“	0 ... 400% 1%	50%
PO	I component of field weakening controller only <u>with</u> servo mode = ON	„field weaken. I“	0 ... 100%/ms 0.1%/ms	10%/ms
PO	Field weakening limit only <u>with</u> servo mode = ON	„limit field weak“	0 ... 100% 1%	100%
PO	ISD control gain only <u>with</u> ISD control, only <u>without</u> servo mode	"ISD control gain"	25 ... 400% 1%	100%
	This parameter will change the control parameters for vectorial current control. As a result of higher values the system will respond to control deviations faster and more dynamically.			

7.1.6 Information parameters

Type	Function Comment	„Display indicates:“	Range of values Resolution	Default setting
	New error(s) Errors can be acknowledged with the Enter key or a digital input programmed for this job.	„new error“	-	-
	Previous error 1 The service condition of the inverter prevailing at the time when the last five error messages were generated is stored. The following information is captured in each case: <ul style="list-style-type: none"> • set of parameters • operating hours • frequency • d.c. link voltage • current intensity • inverter temperature This information can be called with the value keys when the respective previous error is displayed.	„previous error 1“	-	-

Type	Function Comment	„Display indicates:“	Range of values Resolution	Default setting
	Previous error 2 as in previous error 1	„previous error 2“	-	-
	Previous error 3 as in previous error 1	„previous error 3“	-	-
	Previous error 4 as in previous error 1	„previous error 4“	-	-
	Previous error 5 as in previous error 1	„previous error 5“	-	-
	Error statistic Error no. = 0 ... max -Paging with the value keys	"err. stat.: →"	-	-
	Working hour meter Recording of the operating time begins as soon as the frequency inverter is connected to mains voltage and ready for operation.	„operating period“	Hours : minutes : seconds	-
	Event MFR1 Display of the event that tripped the relay	„event MFR1“	The initial letter of the fault that triggered the relay is indicated. Comp. item 7.1.4	-
	Event MFR2 Display of the event that tripped the relay	„event MFR2“		-
	Software version Use the value keys to view the version number and date.	„software vers. →“	-	-
	Operating data display 1 Display of current operational data picked up at the inverter output	„F/Hz Id/A Iq/A“	F/Hz: Inverter output frequency in Hz Id/A: Field-producing current component in A Iq/A: Moment-producing current component in A	
	Operating data display 2 Display of current inverter data picked up at the inverter output	„s/% T/% min-1“	S/%: motor slip in % T/%: motor torque in % min-1: motor speed in rpm, only with encoder feedback	
	Operating data display 3 Display of current inverter data	„KK/°C kHz Ud/V“	KK/°C: Heat sink temperature in °C kHz: Current switching frequency in kHz Ud/V: Inverter d.c. link voltage in Vdc	

7.1.7 Service parameters

Apart from the first menu item, this category of parameters is not accessible to viewing unless the correct password has been entered. These parameters are exclusively required for final quality inspection and of no avail for the user.

Type	Function Notes	„Display indicates:“	Range of values Resolution	Default setting
	Service password	„service password“	0 ... 9999 1	-

7.2 Menu item information

In this section we are going to discuss some major menu groups and menu items in greater detail.

7.2.1 Operating mode (basic parameters)

The *operating mode* menu item in the basis parameters defines the extent to which the digital control inputs can be programmed and states the factory settings.

In the tables below, the functions users may set themselves are marked with a *. A **o** marking identifies those which are factory-set.

Once adjusted the mode will always apply to all parameter sets - it is not possible to select different modes for the various parameter sets.

7.2.1.1 The "analog" operating mode

This operating mode allows for the implementation of standard applications where a potentiometer or an external voltage source are used to fix an analog setpoint, and where no further presettings are required.

As for the „quick stop “ and „cut off voltage“ functions it should be remembered that these are low-active inputs. In order to operate the drive which means that the „quick stop“ or „cut off voltage“ functions are not to be executed, either input must be at voltage (high) before the inverter can be enabled.

Function	DI1	DI2	DI3	DI4	DI5	DI6	active
No function		*	*	*	*	*	high
Enable (right)	o						edge/high
Enable (left)		o					edge/high
Sense of rotation		*					high
Fault acknowledgement		*	*	*	*	o	edge
Param. set change-over input 1				o			high
Param. set change-over input 2					o		high
Cut off voltage		*	*	*	*	*	low
Quick stop		*	*	*	*	*	low
Fixed frequency 1		*	o	*	*	*	high
Fixed frequency 2		*	*	*	*	*	high
Fixed frequency 3		*	*	*	*	*	high
Remote control		*	*	*	*	*	high

Sense of rotation: The sense of rotation is always determined by whether enable left or enable right has been selected, or by the analog setpoint (\pm) respectively.

Remote control: With this function inverter control can be shifted from the control terminal strip (digital inputs 1 - 6) to the RS485 interface (BUS mode) and vice versa.

Low → digital inputs 1 - 6
High → RS 485, BUS mode

For remote control to work properly the parameters relating to the RS 485 interface must have been correctly set!

7.2.1.2 "Motor potentiometer" operating mode

A motor potentiometer function is primarily used for crane control systems. A two-step push-button is provided to enable the inverter and to increase the frequency. The extent to which the frequency may rise depends on the adjusted maximum value.

The first step of the push-button controls the inputs DI1 or DI2 (enable right or left), and the second step controls the *increase-frequency-function*.

If only the enabling function is activated (first step), frequency is maintained at a constant level or at least the set minimum frequency is supplied. If both inputs are opened, frequency decreases until standstill or until the first switching step is operated again.

Suggested circuit:

- S1 = enable right
- S2 = enable left
- S3 = reduce frequency
- S4 = increase frequency

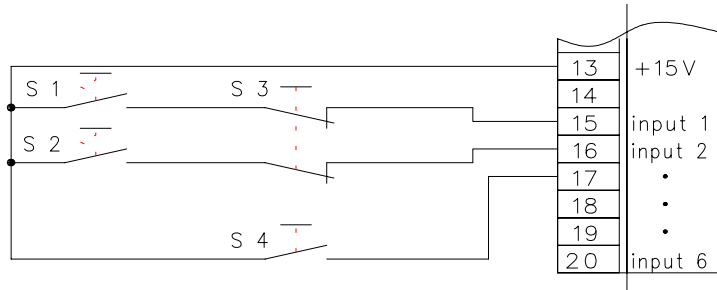

Please note: Storage of the last output frequency set is not possible since the enable input is assigned the "reduce frequency" function as well!

Function	DI1	DI2	DI3	DI4	DI5	DI6	active
No function				*	*	*	High
Enable right	o						Edge/High
Enable left		o					Edge/High
Fault acknowledgement				*	*	o	Edge
Param. set change-over input 1				o			High
Param. set change-over input 2					o		High
Cut off voltage				*	*	*	Low
Quick stop				*	*	*	Low
Increase frequency			o				High
Remote control		*	*	*	*	*	high

7.2.1.3 Operating mode, general

- All options that have not been selected are regarded as being connected to logical zero, with no effect whatsoever on the performance of the inverter.
- DI1 is not programmable and always has the function „enable“.
- If the function „enable left“ is programmed, the function „enable“ is interpreted as „enable right“.
- The two functions "sense of rotation" and "enable left" exclude each other, i.e. only one of the two functions can be programmed.
- A Low/High edge is required for fault acknowledgement.
- If one change-over of parameter sets is to be carried out through but one digital input, the only input affording this possibility is parameter set input 1, respectively parameter sets 1 and 2 (DI4).
- If the "motor potentiometer" mode is set, DI2 and DI3 are permanently programmed.
- Even if control does not take place locally, the functions "cut off voltage" and "quick stop" are still available. Owing to this feature an EMERGENCY STOP function can be provided even if the inverter is controlled via the RS485 interface using the USS protocol.

ATTENTION! Please observe the accident prevention regulations which are customary in your place!

7.2.2 Keyboard control (extra functions)

If the keyboard control feature is activated, direct intervention via the inverter keys is possible. The only way to change the control mode is to return to the standard operating value display.

The start-stop function is assigned to the Enter key, and the setpoint (including the sense of rotation) to the value keys. Simultaneous operation of the value keys will set the setpoint to zero.

If the frequency inverter is started via the Enter key, initial frequency is always 0Hz, regardless of whether the minimum frequency was programmed to a value > 0Hz.

The frequency change always proceeds in accordance with the adjusted ramps (basic parameters) until the moment a limit value is reached.

The control functions previously described which are ensured via the control terminal strip cannot be used in this mode. Neither does the system accept an analog setpoint applied to the setpoint input.

Any error message that may have been generated can be acknowledged with the Enter key after the cause of the error has been eliminated.

The various control jobs will always be executed in accordance with the parameter set selected in the menu item "manipulated parameter set" (Basic parameters).

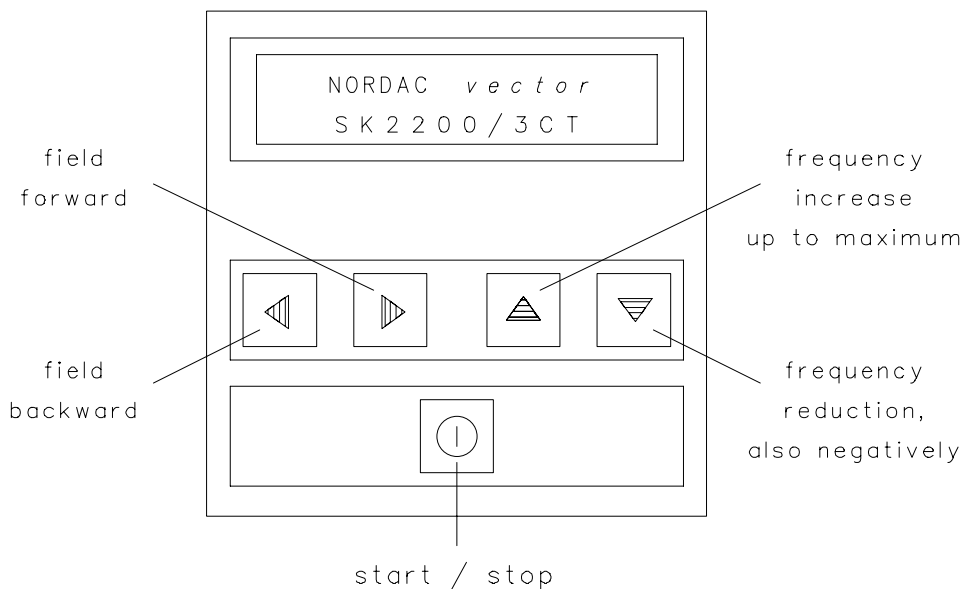

Important note ! Starting the inverter with the Enter key (keyboard control) means that it will have to be the Enter key again, or else a Value key, that must be used to stop it after returning to the operating value display !

7.2.3 Fixed frequencies

Fixed frequencies can be set and used provided that the "analog" mode has been selected in the operating mode menu item (Basic parameters). After that the digital control inputs can be programmed to a total of 3 fixed frequencies.

The „Extra functions“ menu group allows for setting the respective values of the individual fixed frequencies. Settings which are negative in sign are admissible too. A negative sign will result in the sense of rotation being reversed, starting from the control input (right/left) or in a subtraction being made from an analog setpoint.

Addition of the fixed frequencies may also produce a negative result and hence a reversal of the sense of rotation.

7.2.4 USS mode

The RS 485 interface permits communication with the frequency inverter based on the master-slave principle with the USS protocol (a universal interface protocol) serving as the access procedure. The inverter can be operated as either the master or the slave unit.

Please don't hesitate to contact us if you would like detailed information on the USS protocol.

Slave

This mode allows for the frequency inverter to be parameterized and controlled via the serial bus. To enable control of the frequency inverter by way of the bus, the "interface" parameter must be set to "USS". If a PC is to be used as a master, the NORDCON operating software is available for communication with the inverter(s).

Master

In the USS modes Master 1 or Master 2, other NORDAC *vector* frequency inverters can be operated via the RS 485 interface. These modes are intended in the first place to put into operation devices which are not equipped with an operating unit.

The recommended baud rate is 38400 baud. The devices (system users) connected to the bus circuit are selected by means of the USS address.

If the Master fails to meet with a response at the contacted address, it automatically searches for another unit and reprogrammes this user to the baud rate and address of the previous one.

Master 1

In this mode a slave frequency inverter can be parameterised and controlled via the keyboard, control terminals and display of the master inverter. When the slave is controlled using the control terminals of the master, the setting of the digital inputs must be identical, and the "interface" parameter in the slave inverter must be set to "USS". Communication is terminated by switching off the USS mode.

Master 2

In this mode the parameter settings (of all parameter sets) are transmitted from the master to the slave. Only frequency inverters belonging to the same class of output capacities can be used for this mode.

Master 3

This mode is characterized by the fact that it is the control functions (analog setpoints and digital inputs) which are transmitted from the master inverter to the slave inverters connected -> synchronization control (pilot frequency).

7.2.5 Speed controller

The speed of the connected motor can be controlled in two different ways:

1. with an analog actual value signal, processed by the integrated PI or PID controller which is provided as standard
2. using an incremental shaft encoder fitted to the motor, and the incremental shaft encoder input with PI control which is available as **optional** equipment.

7.2.5.1 Controlling the speed with an analog actual value

Analog input 2 is an analog actual value input provided for the purpose of controlling analog variables, as in speed control with tachometer feedback, pressure control with a pressure transducer, or tension control with a dancing roller.

a) PI Controller Setting the analog input 2 function: **Actual frequency value**

PI controller typically used to control dynamic processes, as in speed or dancing roller control.

The PI controller will allow for acceleration ramps only in a setpoint setting mode, it will not do so at the controller output.

b) PID Controller Setting the analog 2 input function: **PID Controller**

PID controller for control processes characterized by actual values changing at a slow rate, as e.g. pressure regulation.

The acceleration ramp is ensured downstream of the PID controller in accordance with the maximum frequency and the acceleration period (Basic parameters).

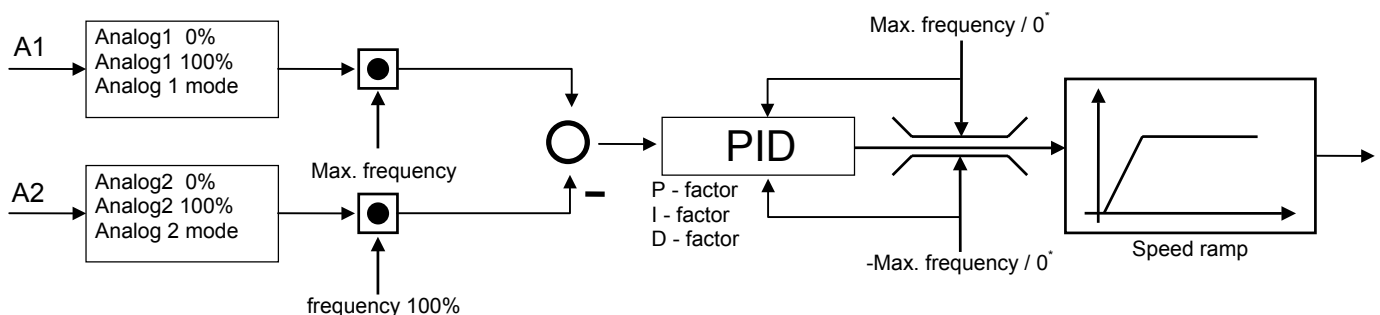

Analog actual value signal: Use the DIP switch on the control board to choose between a current or a voltage actual value signal. The exact shape of the signal is specified in the setpoint input 2 mode parameter.

If the setting is **0..10V limited** or **0(4)..20 mA** and if the control offset is negative, the minimum output frequency will be 0 Hz, i.e. there will be no reversal of the rotational direction of the drive.

If the setting is **0..10 V** or **± 10 V**, the output frequency will be reversed if necessary when the control offset becomes negative, i.e. the rotational direction of the drive may change too.

Analog input 2 must be allocated either the **"actual frequency value"** or the **"PID controller"** function. Then go on by selecting any alignment functions required (see above) and by setting the parameters relevant for the PI/PID controller as provided in the "control terminals" sub-menu.

Frequency 100%: At this point enter the frequency value the controller recognizes at 100% of the analog actual value (voltage or current respectively with 100% alignment of analog input 2).

If the setpoint and the actual value differ with regard to normalization, there is the possibility of setting a ratio max. frequency / frequency 100% corresponding to the ratio setpoint value/ actual value.

If the amounts of setpoint and actual value are equal, set the maximum frequency offered in the applicable parameter set.

PI controller P: Frequency jump in case of a control deviation, related to the control variance.

PI controller I: Frequency change / time, related to the control variance.

PI controller D: Frequency * time, related to the control variance, only with PID controller function.

Limit PI controller: maximum difference between output frequency and frequency setpoint (only with PI controller, actual frequency value)

Example: $f_{\max} (V_{\text{set}} = 10\text{V}) = 70 \text{ Hz}$,

$V_{\text{set}} = 5.0\text{V}$, $f_{\text{set}} = 35 \text{ Hz}$

limit PI controller = 10 Hz

Frequency will be limited within a range 25 to 45 Hz.

PI controller T: Attenuation time constant of the controller. The response time of the PI (T) controller is set. The attenuation time constant has an effect on both the setpoint and the actual value. The constant is not required for standard applications (only with PI controller, actual frequency value).

Starting-up: Speed control with d.c. voltage tachometer

Maximum actual value voltage must never exceed 10 V.

Control parameters need not necessarily be adopted as they are - see if you can't improve their efficiency until they are optimum. Where heavy centrifugal masses are involved, as e.g. in revolving tables, it is advisable to reduce the I component even before the inverter is put into operation for the first time.

The best way surely is to optimize the initial transient process by evaluating the speed supplied by the analog output or by oscillographing the actual value voltage.

Starting-up: Pressure control

Connect the analog actual value signal (output of pressure sensor) to the analog input 2 of the inverter. Allocate the "**PID controller**" function to analog input 2.

At the beginning parameter settings should be as indicated below:

Frequency 100% : maximum frequency in the parameter set being used

PI controller P : 10.0% (factory setting)

PI controller I : 1.00%/ms (factory setting)

PI controller D : 0.00%ms (factory setting)

Then go on by optimizing drive control with the parameters PI controller P, PI controller I, and PI controller D. Experience has shown that in pressure control low I factors should preferably be used.

7.2.5.2 Control with a digital actual value (optional)

This type of control is superior in many respects to other techniques or uncontrolled systems.

- maximum torque even at standstill
- torque limit can be set with great accuracy
- no risk of the motor pulling out
- exact speeds and true running even at very low speeds down to "zero"

Digital actual value signal: Prior to starting-up connect the incremental shaft encoder which is mounted to the motor as indicated in the Instructions For Use (cf. section 4.2).

The rotating field of the incremental encoder must be identical with that of the motor. If this is not the case (e.g. in NORD motors with HG 660 transducer), tracks A+ and A- must be interchanged.

The "Extra Functions" menu group includes the "**Servo Mode**" parameter (only with the CTD option). When this parameter has been programmed to "ON", the display will show the parameters through which this type of control can be optimized.

Shaft encoder resolution : This is where to set the number of increments/revolution of the incremental shaft encoder being used. High resolution factors will enhance control action, especially when speeds are low.

Normalization of the control parameters is such that any increase of the P or of the I component values will accelerate control response. They shouldn't rise too high though because this would result in excessive oscillations of the controller. If by way of contrast the said components are reduced, transient oscillation is smoothed but also prolonged in duration.

Speed controller P: Frequency jump on control deviation, related to control variance

Speed controller I : Frequency change / time, related to control variance

Current controller P : Frequency jump in case of control deviation, related to control offset.

Current controller I : maximum voltage change that can be brought about by the current controller

Field weakening controller : The field weakening controller controls the flux setpoint whenever frequencies are in the field weakening range, and thus determines the v/f (voltage/frequency) break point.

Starting-up: Speed control with incremental shaft encoder feedback

As the factory settings cannot be ideal for any application, it is all right for you to modify and optimize the control parameters. For instance if large flywheel masses are involved as in revolving tables, lower the I-factor of the speed controller even before putting the drive into operation.

As for the current controller parameters, further adjustment of the factory settings will rarely be necessary.

The transient process can best be optimized by evaluating the speed supplied by the analog output or by oscillographing the actual value voltage.

8 Settings after the first starting-up

We suggest that after starting-up the inverter for the first time you should record all relevant settings in the tables below. Remember that depending on parameter configuration some menu items (shaded) are not visually represented in the display. As for menu items which are independent of any particular parameter set having been selected, the table shows a continuous line without partitions.

8.1 Basic parameters

Menu item	Factory setting	Parameter set 1	Parameter set 2	Parameter set 3	Parameter set 4
Acceleration time	...s				
Deceleration time	...s				
Min. frequency	0.0Hz				
Max. frequency	70.0Hz				
Control mode	ISD control				
Mode	analogue				

8.2 Motor data

Menu item	Factory setting	Parameter set 1	Parameter set 2	Parameter set 3	Parameter set 4
Standard motor	...kW				
Nominal frequency	50Hz				
Rated speed	...min-1				
Nominal current	...A				
Nominal voltage	400V				
Nominal power	...kW				
Nominal cos φ	...				
Motor connection	delta / star				
Stator resistance	... Ω				
No-load current	...A				

8.3 Control parameters

Menu item	Factory setting	Parameter set 1	Parameter set 2	Parameter set 3	Parameter set 4
Acceleration delay	On				
Current limit 1	...A				
Current limit2	...A				
Braking delay	Off				
Ramp down	On				
Corner frequency	50Hz				
Static boost	10.0V				
Dynamic boost	0.0V				
Duration dynam. boost	0.0s				
DC braking	Off				
Time DC braking	1.0s				
DC braking voltage	...V				
Setpoint delay	0.0s				

Ramp smoothing	0.0s				
Flying start	Off				
Flying start offset	0Hz				
Flying start resolution	1.0Hz				
Slip compensation	On				
Autom. freq. increase	Off				
Torque limit	Off				

8.4 Control terminals

Menu item	Factory setting	Parameter set 1	Parameter set 2	Parameter set 3	Parameter set 4
Mode anal. input 1	0..10V				
Alignm. 1: 0% →V 0.00V				
Alignm. 1: 100% →V 10.00V				
Filter anal. input 1	Off				
Funct. anal. input 2	None				
Mode anal. input 2	0..10V				
Alignm. 2: 0% →V 0.00V				
Alignm. 2: 100% →V 10.00V				
Filter anal. input 2	Off				
Frequency 100%	50Hz				
PI controller P	100%				
PI controller I	10%/s				
PI controller T	2ms				
PI controller D	0%ms				
Limit PI controller	10Hz				
Current limit 100%	...A (1.5 I _{NFU})				
Torque limit 100%	100%				
Analog output	Off				
Norm. anal. output	100%				
Digital input 2	enable left				
Digital input 3	fixed frequency 1				
Digital input 4	parameter set 1				
Digital input 5	parameter set 2				
Digital input 6	fault acknowledge				
Enable active	edge				
Mot. temp. protect.	Off				
Relay 1 functions	current: OFF frequency : OFF brake: OFF temp.: OFF overcurr.:OFF ramp-up:OFF contour:OFF slippage: OFF torque: OFF regen. torque: OFF FS = F : OFF inact. fault : OFF	fault	fault	fault	fault
Relay 1 logic	OR				

Relay 1 current	...A				
Relay1 I hyst.	10%				
Relay 1 frequ.	50.5Hz				
Relay 1 contouring	100min ⁻¹				
Relay 1 torque limit	300%				
Relay 2 functions	current: OFF frequency: OFF brake: ON temp.: OFF overcurr.: OFF ramp up: OFF contour.: OFF torque limit: OFF Fs = F: OFF inact. fault: OFF				
Relay 2 logic	OR				
Relay 2 current	...A				
Relay 2 I-hyst.	10%				
Relay 2 frequ.	50.5Hz				
Relay 2 contour.	100min ⁻¹				
Relay 2 torque limit	300%				

8.5 Extra functions

Menu item	Factory setting	Parameter set 1	Parameter set 2	Parameter set 3	Parameter set 4
Language	German				
Keyboard control	OFF				
Password	0				
Password change	0				
Fixed frequency 1	10.0Hz				
Fixed frequency 2	20.0Hz				
Fixed frequency 3	40.0Hz				
Power loss reduct.	OFF				
Switching rate	8kHz (4kHz)				
Skip frequ. 1 uplim	OFF				
Skip frequ. 1 lowlim	OFF				
Skip frequ. 2 uplim	OFF				
Skip frequ. 2 lowlim	OFF				
Quick stop at fault	OFF				
Quick stop time	0.1s				
Autom. acknowl.	0				
Abs. min. freq.	1.0Hz				
Line voltage	autom.				
USS mode	slave				
Interface	local				
Baud rate	9600 baud				
BUS address	0				
BUS time-out	0				
Rstat adaption	Off				
Servo mode	Off				

Shaft encoder incr.	4096 pulses/revol.				
Speed controller P	100%				
Speed controller I	10%/s				
Current controller P	150%				
Current controller I	30%/ms				
Limit current contr.	100V				
Field weakening P	50%				
Field weakening I	10%/ms				
Field weaken. limit	100%				
ISD control gain	100%				

9 Warnings and faults

The majority of the frequency inverter functions and operating data is constantly monitored and compared with limit values. On detecting a deviation, the inverter reacts by putting out a warning or a fault message. This reaction is instantly represented in the display. As soon as the message goes out or starts to flash the inverter is able to resume operation.

Warnings (W) → provide information indicating that the inverter is operating near a limit value, without the situation being critical enough to cause disconnection right then, but which could eventually do so if it grew worse.

Faults (F) → The inverter is switched off, the fault is indicated in the display. While the fault is being indicated it cannot be reset. When the fault display starts to flash, the cause of the fault has ceased to exist and the error memory can be reset. Reset is executed with the *Enter key*, by switching the mains OFF/ON or with the automatic acknowledgment function.

Previous faults 1-5 : For the last five fault messages the inverter stores not only the fault itself but also the respective condition of the inverter at the moment the faults occurred. The following data are captured:

- Parameter set
- Operating hours
- Frequency
- d.c. link voltage
- Current
- Inverter temperature

These can be retrieved with the value keys when any of the previous faults is indicated. The previous faults are found in the information parameters.

Error statistic: For all fault messages that can possibly be generated the number of their occurrence is registered and stored. This menu item is found in the information parameters. Any individual fault can be called with the value keys.

9.1 List of warnings and error messages included in the programme

The following table lists all warnings and fault signals the system is able to produce. They are shown in clear text in the inverter's display:

Warnings (W) and faults (F)	Cause	What to do about it
Mains failure (W)	<ul style="list-style-type: none"> • Failure of all 3 mains phases 	<ul style="list-style-type: none"> • Check mains voltage
Acceleration overcurrent (W)	<ul style="list-style-type: none"> • The acceleration ramp was protracted until current limit 1 was reached, cf. Control parameters. • Frequency was reduced, current limit 2 was reached, cf. Control parameters. 	<ul style="list-style-type: none"> • Set a longer acceleration time. • Reduce the loading of the drive. • Raise current limits 1 and/or 2.
Inverter overtemperature (W / F) W => temperature limit 1 F => temperature limit 2	<ul style="list-style-type: none"> • Ambient temperature is too high • Inadequate ventilation, louvres are obstructed • Failure to install the unit in vertical position 	<ul style="list-style-type: none"> • Check/improve ventilation of the switch cubicle. • Check temperature of inverter environment, max. 40°C. • Follow installation/mounting instructions, item 2 .

Warnings (W) and faults (F)	Cause	What to do about it
<p>Motor overtemperature (W / F)</p> <p>W => PTC resistor has triggered F => sustained warning for > 30 s</p>	<ul style="list-style-type: none"> The connected PTC resistor has triggered, the motor is overloaded. Control terminals 11 and 12 are not connected 	<ul style="list-style-type: none"> Improve cooling of the motor. Check whether motor size is right for the application Connect PTC resistor or bridge control terminals. Switch off function → Extra functions
<p>Overcurrent (I²t monitoring) (W / F)</p> <p>W => inverter is working in overcurrent range F => inverter has been working in overcurrent range <u>too long</u></p>	<ul style="list-style-type: none"> The internal overcurrent trip has responded, overcurrent must have been at least 1.2 times the rated inverter current. Inappropriate motor-inverter combination. Acceleration or deceleration period too short 	<ul style="list-style-type: none"> ISD control: check motor data. Linear characteristic: check v/f break point and boost (Basic and control parameters) Check configuration of the drive. Extend acceleration or braking time.
<p>Module overcurrent (F)</p>	<ul style="list-style-type: none"> Short circuit at the output Earth fault at the output Overcurrent Overtemperature 	<ul style="list-style-type: none"> Check motor cable/motor connection Check braking chopper cable/connection Check inverter/motor loads
<p>Overvoltage (F)</p>	<ul style="list-style-type: none"> Mains voltage too high Too much energy fed back by the motor. Braking time is too short. No braking resistor at all or braking resistor impedance too high 	<ul style="list-style-type: none"> Check mains voltage and reduce if necessary. Check braking resistance value Extend braking time Check connection of the braking resistor.
<p>Undervoltage (F)</p>	<ul style="list-style-type: none"> Mains voltage too low Mains voltage interruption, while the motor is working 	<ul style="list-style-type: none"> Please check mains connection for supply of three phases and sufficient voltage level!
<p>Phase failure (F)</p>	<ul style="list-style-type: none"> One of the mains input phases is having/has had an interruption. Mains voltage too often turned OFF an ON in one hour (see section 9.5) 	<ul style="list-style-type: none"> Please check mains connection for supply of three phases and sufficient voltage level!
<p>Parameter loss (F)</p>	<ul style="list-style-type: none"> EEProm is defective Noise pulses on the cables New inverter type was set with DIP switch 	<ul style="list-style-type: none"> Reset fault signal Repeat parameter setting!
<p>USS time-out (F)</p>	<ul style="list-style-type: none"> Error in USS data transmission 	<ul style="list-style-type: none"> Check message downtime, extend it if necessary Switch off this monitoring feature when the NORD-CON software is used

Warnings (W) and faults (F)	Cause	What to do about it
System errors 1 – 13 (F)	<ul style="list-style-type: none"> • Error in the internal program flow 	<ul style="list-style-type: none"> • See section 9.4

9.2 Possible overcurrent (W/F)

The overcurrent monitoring relay trips when the internal I^2t limit value is exceeded. The limit value setting allows for 1.5 times the rated inverter current to be put out for 30 seconds. For lesser overcurrent values some more time will be available while higher overcurrents are tolerated for an even shorter period of course. When the current level has been too high too long, overcurrent circuit breaking will follow.

9.3 Quick stop at major faults

Depending on the circumstances the quick stop function (cf. 7.1.5 Extra functions) is usually activated when the following incidents occur:

- inverter overtemperature
- motor overtemperature
- phase failure
- USS time-out
- mains failure

This function will decelerate the motor to a stop as quickly as possible provided that it is safe to let operation go on for a little while and provided also that there is enough energy in the inverter or else can be recovered from the motor.

9.4 System errors 1-13

If any of the system errors occurs repeatedly you should get into touch with the supplier of the inverter.

In the majority of cases such errors are caused by interferences with the programme flow due to insufficient electromagnetic compatibility. Sometimes too system errors may be the result of a component being defective.

To ensure full electromagnetic compatibility the recommendations mentioned in item 10.1 should be followed.

If the system accepts a reset of these signals, operation of the inverter can be continued.

9.5 Max. mains voltage switching cycles

To protect the frequency inverter from damage, use the controller enable function if required rather than to exceed the switching cycle limits mentioned in the table below.

SK 1500/3 CT ... SK11000/3 CT	250 times/h
SK 15000/3 CT ... SK 37000/3 CT	125 times/h
SK 45000/3 CT ... SK 132000/3 CT	50 times/h

10 EMC measures

10.1 Radio interference suppression level

If a mains filter we have recommended is used and if shielded motor, brake resistor and mains cables between filter and inverter are employed, radio interference suppression in accordance with **EN 55011 resp. EN 50081 limit curve B** is ensured for devices **up to 37kW** provided that the pulse rate is **8kHz** .

Radio interference suppression in accordance with **EN 55011 resp. EN 50081 limit curve A** is ensured for devices **from 45 to 132kW** at a pulse rate of **4kHz** provided that a mains filter we have recommended is used and that shielded motor, brake resistor and mains cables are employed between filter and inverter.

Connect the cable shield to earth on both sides. Where the shield meets the inverter lay it on the metal front panel of the inverter using a PG brass screwing (devices up to 37kW). In addition the cable shield must be connected to the inverter's PE terminal.

10.2 Noise immunity

Even if connecting and control cables are used without a shield, the frequency inverter is interference-proof up to **severity level 4** in accordance with **IEC 801-2 and IEC 801-4**.

Shielding for noise immunity will only be required in cases where severity level 4 is inadequate. Connect inductivities (contactors, braking coils etc.) or employ suitable mains filters if necessary.

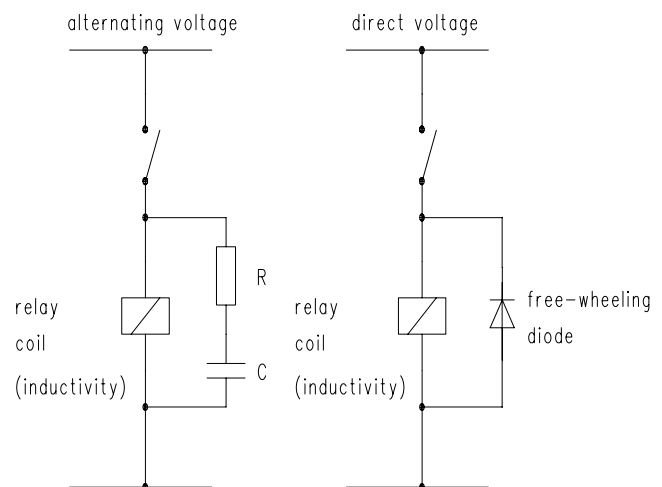

11 CE marking

NORDAC *vector* frequency inverters are electrical equipment for application in industrial plant. They are designed to be used in machines for speed control of three-phase motors. Information and recommendations for installation are contained in the operating instructions.

NORDAC *vector* frequency inverters are CE-marked as stipulated by the European Low-Voltage Directives 73/23/EWG and 93/68/EWG. An EC-conformity statement can be issued if required.

Frequency inverters are not devices as defined in the EMC directives since they are exclusively produced as ancillary supply parts to be further processed by industry and craft and cannot be operated on their own.

By implementing the measures recommended in 10.1, meeting the requirements for observance of the EMC directive 89/336/EWG is ensured. A manufacturer's statement can be issued if required.

12 Additional measures (OPTIONAL EQUIPMENT)

12.1 Mains filters

To ensure that radio interference suppression levels are met as required, various types of mains filters are available for different rated currents.

Recommended mains filters				
Inverter type	Voltage	Power	Mains filter type	Filter current
SK 1500/3 CT + SK 2200/3 CT	380 ... 460 V	1,5 / 2,2 kW	HFD 511 - 460 / 8*	8 A
SK 3000/3 CT to SK 5500/3 CT	380 ... 460 V	3,0 / 5,5 kW	HFD 511 – 460 /17*	17 A
SK 7500/3 CT + SK 11000/3 CT	380 ... 460 V	7,5 / 11,0 kW	FS 3981 - 30 / 99	30 A
SK 15000/3 CT + SK 22000/3 CT	380 ... 460 V	15,0 / 22,0 kW	HFD 511 – 460/60*	60 A
SK 30000/3 CT + SK 37000/3 CT	380 ... 460 V	30,0 / 37,0 kW	FS 3981 - 100 / 99	100 A
SK 45000/3 CT + SK 55000/3 CT	380 ... 460 V	45 / 55 kW	FN 258 - 130 / 35	130 A
SK 75000/3 CT	380 ... 460 V	75 kW	FN 258 - 180 / 40	180 A
SK 90000/3 CT + SK 110000/3 CT	380 ... 460 V	90 / 110 kW	FN 359 - 250 / 99	250 A
SK 132000/3 CT	380 ... 460 V	132 kW	FN 359 - 300 / 99	300 A

*or types FS 3981 - 8 / 99, FS 3981 – 17 / 99, FS 3981 – 60 / 99 (production being phased out)

12.2 Installation and dimensions of mains filters

Make sure when installing the mains filters that sufficient ventilation is available. A clearance of at least 60mm should be ensured beside the ventilation grid!

Protect the filters against liquids, dust and aggressive gases.

The filters may be fixed on the wall in a vertical position or mounted on the floor in a horizontal position. Optimum filter effectivity is achieved if the filter is placed as close to the inverter as possible.

Mains filters - Dimensions								
Filter type	L	W	D	L1	W1	Attach- ment Ø	Shielded output cables, or terminals respectively	PE input
HDF 511 - 460/8	255	50	126	240	25	6.5	300mm, 4 x 2.5 ²	M5
HFD 511 – 460/17*	305	55	142	290	30	6.5	300mm, 4 x 2.5 ²	M5
FS 3981 - 30 / 99	335	60	150	320	35	6.5	400mm, 4 x 6 ²	M5
HFD 511 – 460/60*	330	80	220	314	55	6.5	500mm ² 4 x 16mm ²	M6
FS 3981 - 100 / 99	379	90	220	364	65	6.5	50mm ² terminals	M10
FN 258 - 130 / 35	429	110	240	414	80	6.5	50mm ² terminals	M10
FN 258 - 180 / 40	438	110	240	413	80	6.5	95mm ² terminals	M10
FN 359 - 250 / 99	564	300	160	210	275	9	Current bar	M12
FN 359 - 300 / 99	564	300	160	210	275	9	Current bar	M12

All dimensions in mm

*) or types FS 3981 - 8 / 99, FS 3981 – 17 / 99, FS 3981 – 60 / 99 production of which is phasing out

HFD 511, FS 3981 and FN 258

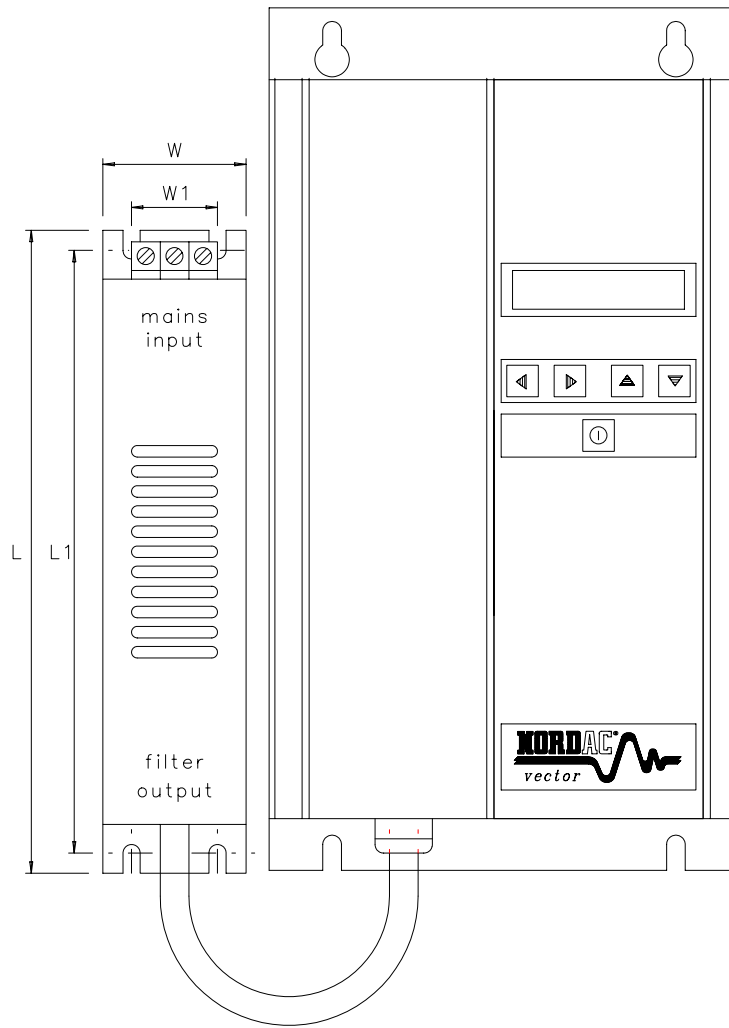

FN 359

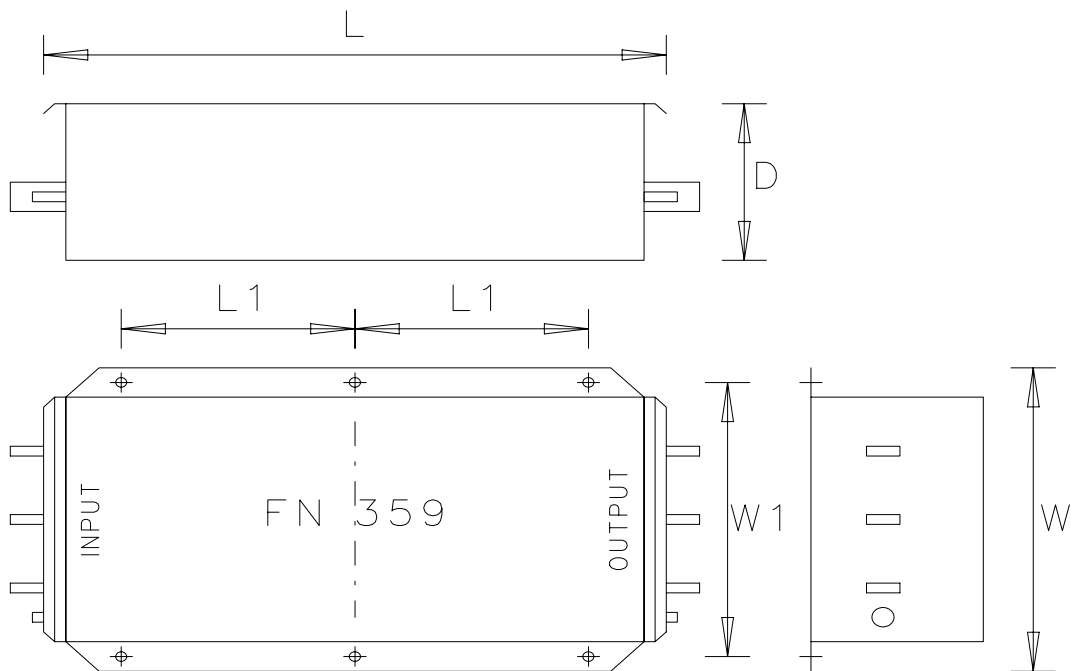

12.3 Brake resistor data and dimensions

The table refers to construction type IP 20 *) fastened with screws. For this resistor type a maximum percentage duty cycle of 3.4% with a cycle period of 120s can be assumed.

Inverter type	Resistor Resistance/Continuous rating	L Length	W Width	D Depth	e	e1	Attach- ment Ø f	Connecting terminals
SK 1500/3 CT ... SK 3000/3 CT	120Ω / 180W	100	65	220	90	45	4.5	2.5mm ²
SK 4000/3 CT ... SK 5500/3 CT	60Ω / 360W	100	170	220	90	105/150	4.5	2.5mm ²
SK 7500/3 CT ... SK 11000/3 CT	40Ω / 540W	100	170	220	90	105/150	4.5	2.5mm ²
SK 15000/3 CT ... SK 22000/3 CT	18Ω / 1600W *	586	185	120	526	150	5.8	2.5mm ²
SK 30000/3 CT ... SK 37000/3 CT	12Ω / 2000W *	486	275	120	426	240	5.8	2.5mm ²
SK 45000/3 CT ... SK 55000/3 CT	8Ω / 3000W *	490	295	260	270	380	10.5x13	M6 Stud terminals
SK 75000/3 CT	6Ω / 4000W *	490	295	260	270	380	10.5x13	M6 Stud terminals
SK 90000/3 CT	4Ω / 5500W *	490	395	260	370	380	10.5x13	M8 Stud terminals
SK 110000/3 CT ... SK 132000/3 CT	3Ω / 7500W *	490	595	260	570	380	10.5x13	M8 Stud terminals

All dimensions in mm

Fig. 1: 120Ω - 40Ω

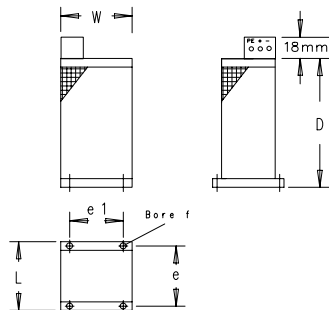

Fig. 2: 18Ω - 12Ω

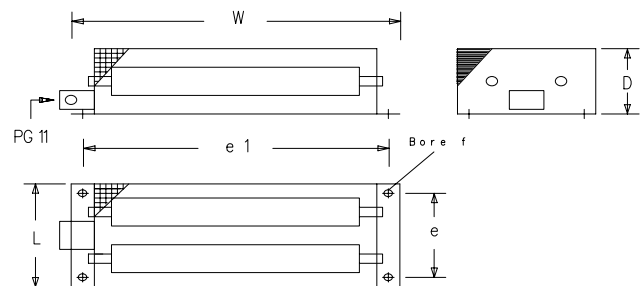
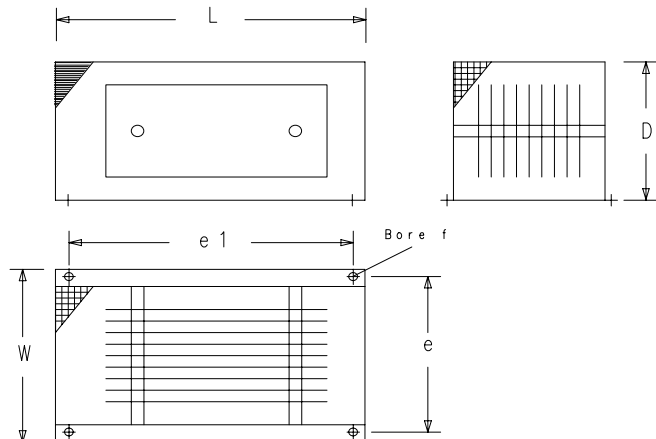

Fig. 3: 8Ω - 3Ω



12.4 Output chokes

If very long motor cables must be used, installation of an output choke may be necessary. With an output choke the cable capacitance developing with great cable lengths can be compensated.

Too high a cable capacitance at the frequency inverter output may cause a module error or result in the generation of an overcurrent message.

For further information please contact the agency or representation of our firm responsible for customer service in your region.

12.5 Sine output filters

Sine filters can be employed for filtering the inverter output signal. In that case shielding of the motor cables will not be necessary.

The inverter load is increased however by approximately 10% if such a filter is used.

Any further questions should be addressed to the agency or representation of our company based in your region.

13 Maintenance and service information

NORDAC vector frequency inverters are maintenance-free if they are operated in accordance with instructions (cf. item 2.0).

If the frequency inverter is operated in an environment with very dusty air, the cooling surfaces must be cleaned with compressed air at regular intervals. If the switch cabinet is provided with air inlet filters, they too must regularly be cleaned or replaced.

When the inverter is in need of repair, send it to your local agent or distributor, please.

Please note that any components which are still attached to the frequency inverter when it is sent to us for repair, such as power cables, potentiometers, external display modules, etc. shall be excluded from the guarantee covering the device.

Better remove any parts which are not genuine from the frequency inverter.

14 *NORDAC vector* for square load torque (VT)

In addition to the *NORDAC vector* frequency inverter type CT for applications with a constant load characteristic, another type series (VT) is available for square load characteristic curves.

To ensure quick access to settings typically required in pump and fan applications and hence optimum ease and efficiency of operation, our engineers purposely dropped a few menu items and narrowed some setting ranges.

Yet control and operation of VT devices are hardly any different as compared with the CT type series. The operating instructions are still applicable.

Apart from ISD control only the square v/f characteristic can be set as a control mode. Any overloading of the inverter is excluded as the output current is limited to the values indicated in the Technical data (cf. section 15.3). As for the pulse rate, only 2 or 4 kHz remain as options for selection.

While configuration of the digital control inputs provides for a fixed allocation of functions, the multifunction relays 1 and 2 still allow parameterization as they do in the CT-type inverters.

Fixed configuration of the control inputs		
Digital input 1	Control terminal 15	Enable right
Digital input 2	Control terminal 16	Enable left
Digital input 3	Control terminal 17	Fixed frequency 1
Digital input 4	Control terminal 18	Parameter set input 1
Digital input 5	Control terminal 19	Parameter set input 2
Digital input 6	Control terminal 20	Fault acknowledgement
same as in control terminal strip item 4.2.1 (in brackets)		

15 Technical data

15.1 General technical data

Function	Range of values
Output frequency	0 Hz ... 999 Hz
Frequency resolution	0.1 Hz
Max. motor lead at the output	approx. 150m without additional output choke, if standard cable is used
Coolant temperature	0°C ... 40°C, air not containing any moisture or aggressive gases
Storage temperature	-20°C ... 70°C, in air free of moisture or aggressive gases
Air humidity	90% rel., no condensation
Installation altitude	up to 1,000m a.m.s.l. without loss of performance
Type of enclosure	IP 20 (alternatively: NEMA 1as an option)
Electrical protection	earth-fault- and short-circuit-proof, stable at no load, protected in case of mains phase failure
Immunity to interference	IEC 801-2 /-4, severity level 4
R.I. suppression degree	in acc. with EN 55011, with optional mains filter and properly connected
Approvals	UL and CSA for SK 1500/3 CT ... SK 11000/3 CT

15.2 Technical data, constant torque (CT → Constant Torque)

Type SK ...	1500/3CT	2200/3CT	3000/3CT	4000/3CT	5500/3CT	7500/3CT
Max. rated power, kW	1.5	2.2	3.0	4.0	5.5	7.5
4 pole motor hp	2	3	4	5	7,5	10
Continuous output power at 400V kVA	2.8	3.8	4.9	6.7	8.6	11.3
Max. continuous output current A	4.0	5.5	7.1	9.7	12.4	16.3
Overload capacity	1.5 times the continuous output current for 30 seconds					
Output voltage	three-phase, 380 V -20% ... 460 V +10%					
Pulse frequency	2 kHz ... 16 kHz, no loss of performance up to 8 kHz					
Recomm. min. brake resistance Ω	120	120	120	60	60	40
Max. chopper current A	15	15	15	15	15	22
Mains voltage	three-phase, 380 V -20% ... 460 V +10%, 50 - 60Hz ± 2%					
Inverter efficiency	approx. 97 %, at 8 kHz and related to the motor output					
Typ. nom. input current (appr.) A	6	8	11	13	17	21
Rec. mains fusing (slow-blow) A	10	16	16	16	20	25
Max. wire cross-section mm²	4	4	4	4	4	4
Weight approx. kg	4.8	5.0	5.0	6.3	6.5	8.0
Cooling with integrated fan	no	yes	yes	yes	yes	yes

Technical design subject to change

Type SK ...		11000/3CT	15000/3CT	22000/3CT	30000/3CT	37000/3CT
Max. rated power,	kW	11.0	15.0	22.0	30.0	37.0
4 pole motor	hp	15	20	30	40	50
Continuous output power at 400V	kVA	16.8	22.2	31.5	41.5	49.2
Max. contin. output current	A	24.3	32.0	45.5	60.0	71.0
Overload capacity		1.5 times the continuous output current for 30 seconds				
Output voltage		three-phase, 380 V -20% ... 460 V +10%				
Pulse frequency		2 kHz ... 16 kHz, no loss of performance up to 8 kHz				
Recomm. min. brake resistance	Ω	40	18	18	12	12
Max. chopper current	A	22	50	50	75	75
Mains voltage		three-phase, 380 V -20% ... 460 V +10%, 50 - 60Hz ± 2%				
Inverter efficiency		approx. 97 %, at 8 kHz and related to the motor output				
Typ. nom. input current (appr.)	A	30	42	56	75	93
Rec. mains fusing (slow-blow)	A	35	50	63	100	100
Max. wire cross-section	mm²	10	input: 16 output: 10	input: 16 output: 10	35	35
Weight approx.	kg	9.0	15	16	23	24
Cooling with integrated fan		yes	yes	yes	yes	yes

Type SK ...		45000/3CT	55000/3CT	75000/3CT	90000/3CT	110000/3CT	132000/3 CT
Max. rated power,	kW	45	55	75	90	110	132
4 pole motor	hp	60	75	100	125	150	200
Continuous output power at 400V	kVA	60	74	97	116	142	170
Max. contin. output current	A	90	112	145	168	201	240
Overload capacity		1.5 times the continuous output current for 30 seconds					
Output voltage		three-phase, 380 V -20% ... 460 V +10%					
Pulse frequency		2 kHz ... 8 kHz, no loss of performance up to 4 kHz					
Recomm. min. brake resistance	Ω	8	8	6	4	3	3
Max. chopper current	A	100	100	150	200	240	240
Mains voltage		three-phase, 380 V -20% ... 460 V +10%, 50 - 60Hz ± 2%					
Inverter efficiency		approx. 97 %, at 4 kHz and related to the motor output					
Typ. nom. input current (appr.)	A	109	130	182	202	246	288
Rec. mains fusing (slow-blow)	A	125	160	200	250	300	300
Max. wire cross-section (B.R. = braking resistor)	mm²	50 35 for B.R.	50 35 for B.R.	50 35 for B.R.	150 50 for B.R.	150	150
Weight approx.	kg	28	28	39	76	78	80
Cooling with integrated fan		yes	yes	yes	yes	yes	yes

Technical design subject to change

15.3 Technical data, variable torque (VT → Variable Torque)

Type SK ...		2200/3VT	3000/3VT	4000/3VT	5500/3VT	7500/3VT	11000/3VT	15000/3VT
Max. rated power,	kW	2.2	3.0	4.0	5.5	7.5	11.0	15.0
4 pole motor	hp	3	4	5	7,5	10	15	20
Continuous output power at 400 V	kVA	3.8	4.9	6.7	8.6	11.3	16.8	20.4
Max. contin. output current	A	5.5	7.1	9.7	12.4	16.3	24.3	29.5
Output voltage		three-phase, 380 V -20% ... 460 V +10%						
Pulse frequency		2 kHz or 4 kHz without loss of performance						
Rec. min. brake resistance	Ω	120	120	60	60	40	40	40
Max. chopper current	A	15	15	15	15	22	22	22
Mains voltage	A	three-phase, 380 V -20% ... 460 V +10%, 50 - 60Hz ± 2%						
Inverter efficiency		approx. 97.5 %, at 4 kHz and related to the rated motor power						
Typ. nominal input current	A	8	10	13	17	21	28	38
Rec. mains fusing (slow-blow)	A	10	16	20	20	25	35	50
Max. wire cross-sectional area	mm²	4	4	4	4	4	10	10
Weight approx.	kg	4.8	5.0	6.3	6.3	8.0	8.8	9.0
Dimensions same as SK...(see item 3.1)		1500/3 CT, 2200/3 CT		4000/3 CT, 5500/3 CT		7500/3 CT, 11000/3 CT		
Cooling with integrated fan		no	yes	yes	yes	yes	yes	yes

Type SK ...		18500/3VT	22000/3VT	30000/3VT	37000/3VT
Max. rated power,	kW	18.5	22.0	30.0	37.0
4 pole motor	hp	25	30	40	50
Continuous output power at 400V	kVA	24.2	30.5	38.1	47.1
Max. cont. output current	A	35	44	55	68
Output voltage		three-phase, 380 V -20% ... 460 V +10%			
Pulse frequency		2 kHz or 4 kHz without loss of performance			
Rec. min. brake resistance	Ω	18	18	12	12
Max. chopper current	A	50	50	75	75
Mains voltage		three-phase, 380 V -20% ... 460 V +10%, 50 - 60Hz ± 2%			
Inverter efficiency		approx. 97.5%, at 4 kHz and related to the rated motor power			
Typ. nominal input current (ca.)	A	45	57	71	89
Rec. mains fusing (slow-blow)	A	50	63	100	100
Max. wire cross-sectional area	mm²	input: 16 output: 10	input: 16 output: 10	35	35
Weight approx.	kg	15	16	23	24
Cooling with integrated fan		yes	yes	yes	yes
Dimensions same as SK ... (see item 3.1)		SK 15000/3 CT, SK 22000/3 CT		SK 30000/3 CT, SK 37000/3 CT	

We are always close at hand - world wide - NORD Gear

Subsidiaries world-wide:

Getriebebau NORD GmbH
Deggendorfstr. 8
A - 4030 Linz

NORD Aandrijvingen N.V. /
Transmission S.A.
Boutersemdreef 24
B - 2240 Zandhoven

NORD-PTI do Brasil Ltda.
Rua José Martins Coelho, 300
04461 - 050 São Paulo SP

NORD Gear Limited
41, West Drive
CDN - Brampton, Ontario, L6T 4A1

Getriebebau NORD AG
Bächigenstr. 18
CH - 9212 Arnegg

NORD Poháněci Technika s.r.o
Palackého 359
CZ - 50002 Hradec Králové

NORD Gear Danmark A/S
Kliplev Erhvervspark 28 - Kliplev
DK - 6200 Aabenraa

NORD Motorreductores
Ctra. de Sabadell a Prats de Llucanès
Aptdo. de Correos 166
E - 08200 Sabadell

NORD Réducteurs sarl.
17-19 Avenue Georges Clémenceau
F - 93421 Villepinte Cedex

NORD Gear Limited
11 Barton Lane
Abingdon Science Park
GB - Abingdon, Oxford OX 14 3NB

Getriebebau NORD
Törökkö u. 5-7
H - 1037 Budapest

NORD Motoriduttori s.r.l.
Via Modena 14
I - 40019 Sant' Agata Bolognese
(Bologna)

NORD Aandrijvingen Nederland B.V.
Voltstraat 12
NL - 2181 HA Hillegom

NORD Drivsystem AB
Ryttargatan 277 / Box 2097
S - 19402 Upplands Väsby

NORD Gear Pte. Ltd.
33 Kian Teck Drive, Jurong
Singapore 628850

NORD-Remas Redüktör
San. ve Tic. Ltd. Sti.
Tepeören Köyü
TR - 81700 Tuzla - Istanbul

NORD Gear Corporation
800 Nord Drive / P.O. Box 367
USA - Waunakee, WI 53597-m0367

Getriebebau NORD
GmbH & Co. KG
Postfach 12 62
22934 Bargteheide

