

1 Introduction

Nearly every electrical component emits electromagnetic radiation during its operation. This has effects on the quality of the useful signals especially at the communication level, in which mostly digital information is communicated with low signal levels and in some cases, over long distances. These influences can cause signal errors and misinterpretations (e.g. in bus communication) and therefore to faults in individual components, up to the failure of complex systems and plants.

To minimise the emission and effect of interference, electrical systems must be installed so that they comply with the requirements of the local EMC regulations.

The following information is a supplement to the manuals for the devices and is a further aid to the implementation of an EMC compliant installation of NORD components.

General installation information

Before installation of cable connections, incl. cable screens in the context of installation of electrical or electronic drive technology, the local mains, earthing and potential situation must be examined. If potential differences (→ possible sources of leakage current) are found, these must be eliminated by the operator by means of suitable methods (potential compensation). In addition the following points must be taken into consideration:

- Shields for electric cables must be connected to large areas of each and with low impedance (e.g. use pipe clips or spring clips).
- Do not twist the ends of the shield together, do not solder wire strands, as this will reduce the effective cross section and cause an impermissible reduction of the shielding effect!
- Install cables by the shortest route and avoid the formation of loops.
- Select cable cross sections (including low voltage) according to the relevant regulations.

The minimum cross sections must be selected so that the supply voltages of the electrical or electronic components do not undershoot the permissible range (the voltage drop in cables is primarily at low voltages with high currents).

- Cables which cause interference and sensitive cables must be installed separately. This is especially true for signal cables and power supply cables.

If crossings of such cables cannot be avoided, these should be at right angles, especially in the case of sensitive signals and causes of interference.

- Unshielded pairs of conductors from shielded cables must be kept as short as possible and must be twisted together.
- The ends of metal cable ducts, metal pipes etc. must overlap and must be connected over a large area so that this is effective at high frequencies.

Technical Information / Datasheet	EMC - Installation of NORD components			
Assembly instructions	TI 80_0011	V 1.0	4414	EN

Earthing, wiring recommendations

Earthing is each connection to a reference potential, which is connected to the conducting ground with a so-called "Earth". Basically a differentiation is made between two types of earthing. *Protective earthing* and *Functional earthing*.

Protective earthing	Earthing which serves to protect people and animals from electric shock.
Functional earthing	Earthing for the normal operation of the electrical system. This is necessary to ensure the electromagnetic compatibility (EMC) compatibility of the system.

Often, the design of the protective earthing is not sufficient to ensure the EMC of the system in addition to personal protection. In many cases it is necessary to connect an additional functional earthing, or to install the protective earthing so that it meets the EMC requirements in addition to providing personal protection ("Combined earthing"). This earthing must fulfil the following criteria:

- It must have a low ohmic resistance and a corresponding current carrying capacity.
- It must have a low inductance, so that high frequency interference signals can be earthed.
- In order for the reference potential to be as free as possible from interference, the earthing must be over a wide an area as possible or in the form of a mesh.
- In the low frequency range, the cross section is decisive for the resistance.
- The bonding cables must have a high current carrying capacity.
- The earthing must have a low resistance to earth and must also have a high current carrying capacity.

i Information **Interference from system components which are not earthed**

All conductive parts of the system, which do not carry the operating voltage in proper use, are potential antennae and can therefore radiate or absorb interference.

In the high frequency range, short cable lengths and low inductances are decisive. A conductor surface which is as large as possible should be aimed for. The contact points must have a large area. The earth must have a low impedance (large area and large contact area) to the ground.

Conductive metal components (water pipes, steel constructions, etc.) are included in the formation of the earthing system. The metal constructions are interconnected at several points in the form of a mesh. For multi-storey buildings, the earths must be connected vertically at several points. The meshed structure of the earthing network results in a large area with short cable lengths and therefore a low impedance, which is essential for good earthing of interference signals. At the same time, such a meshed system forms an earth potential which is the same at all points and only has slight potential differences.

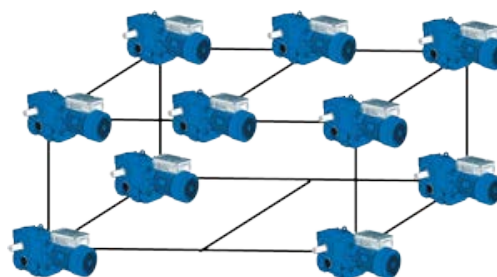

Meshed earthing bands have proved effective for the connection of metal components. Usually, these have cross sections of **10 mm² to 25 mm²**.

If these connections are to be made with round conductors, it is essential that these are in the form of fine wires. Cable shields must be connected at both ends.



2 Electrical connection

Careful installation of all electric supply cables and properly connected wiring are the prerequisites for optimum EMC and trouble free operation of electrical systems. In association with frequency inverters from the series SK 200E and their accessories, the following point must be strictly observed.

Connection to frequency inverter

The following example shows the correct wiring of all obligatory connections and optional components.

The following points must be observed:

- Definite spatial separation of power cables on the one side and bus and 24 V cables on the other side of the connecting unit (SK TIE4-...) with the greatest possible distance between the lines and no crossing of lines (see figure below)
- Spatial separation between the mains supply and the motor cable (see figure below)
- Keep the mains supply cables as short as possible
- Connection of a **10 mm²** PE cable in the connection unit via a cable gland as the functional earthing (1)
- All bus cables must be twisted together (e. g. system bus Sys H (+) with Sys L (-) or PROFIBUS DP *PBR A* with *PBR B*)



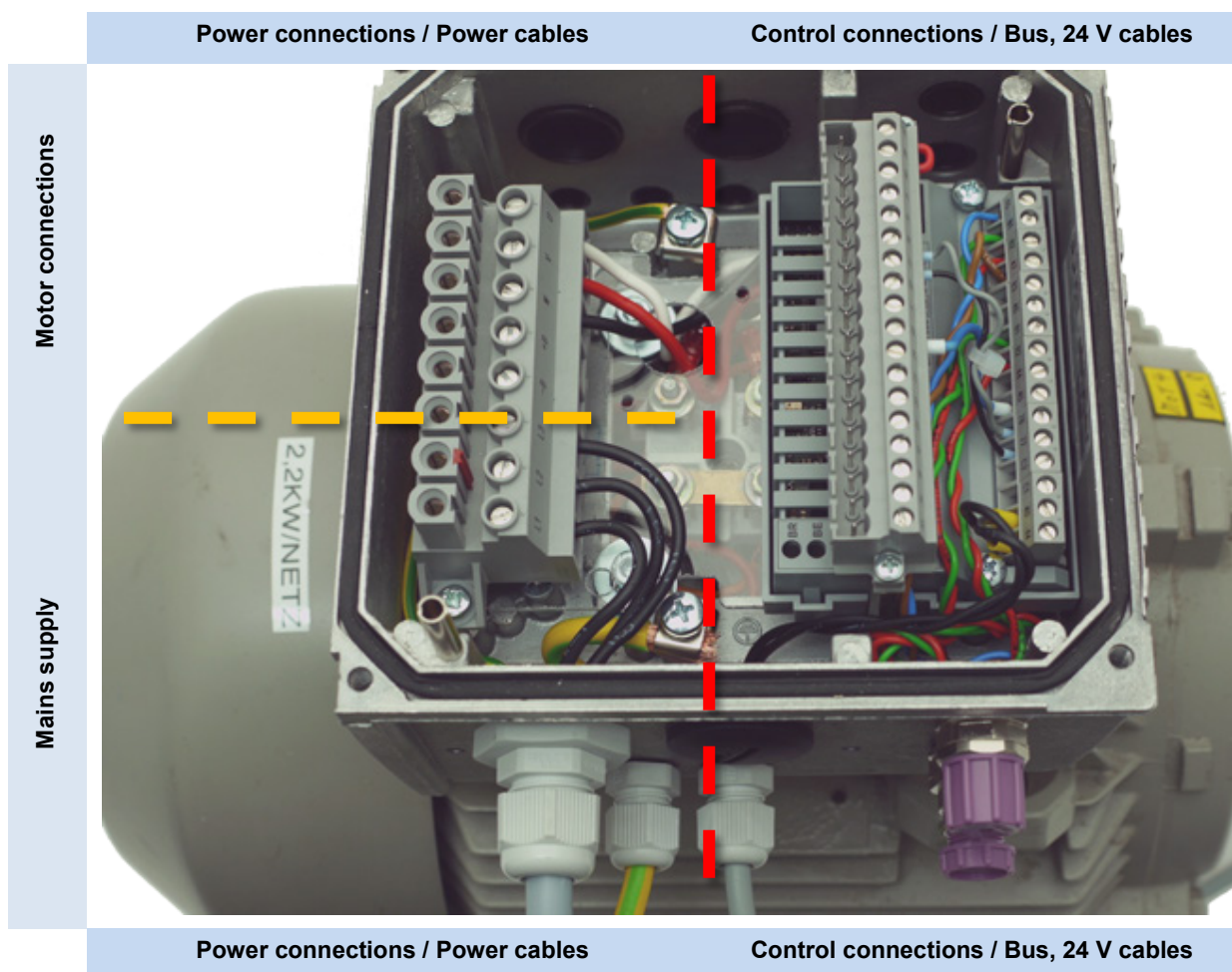

2.1 Connecting the mains voltage at the decentralized device

The M25 cable glands (3AL / 3BL or 3AR / 3BR) must be used to connect the mains voltage.

The mains voltage must be connected so that the mains cables and the motor cables do not cross each other and are spatially separated. The connection cable for the mains voltage in the connection box must be kept as short as possible (please see chapter 0 "Connection to frequency inverter" on page 3).

Can not be avoided that mains and motor cables cross each other, so it must be ensured that a minimum distance of 1 cm is maintained.

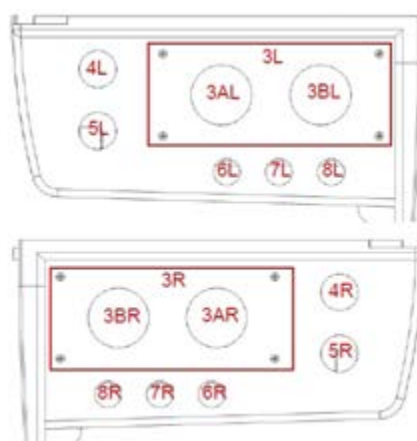

2.2 24 V DC connection

The 24 V DC supply to the bus modules should be in a star configuration. The 24 V mains unit forms the centre of the star.

Care must be taken that the cables are *as short as possible* so that the voltage drop on the 24 V cables is limited. A voltage of ≥ 18 V must be present at the end of the 24 V cable for the particular device, even under load.

The 24 V supply to an internal module of type SK CU4-... (e. g. SK CU4-PBR) should be connected via spur cables, as the contacts of this module only have a permissible current carrying capacity of 1 A.

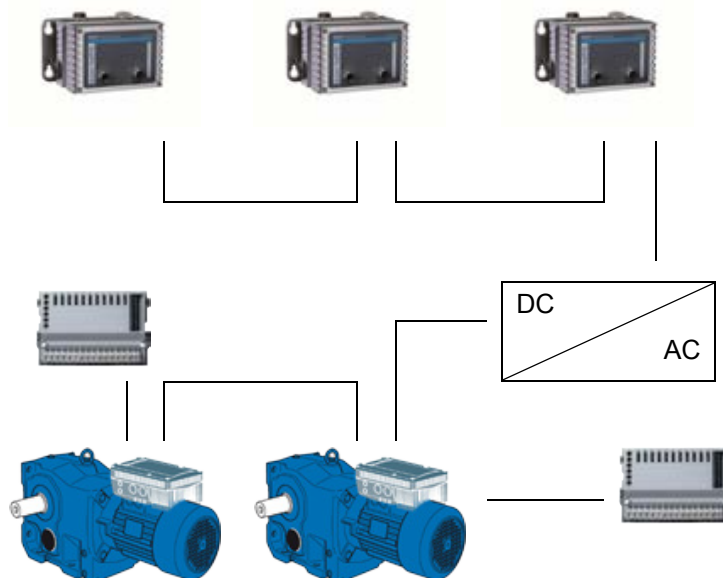

NOTICE

Limited current carrying capacity

The contacts of the module are designed for a limited current carrying capacity. For the 24 V supply of bus modules of type **SK TU4-...** or their connection unit (SK TI4-TU-BUS) a maximum of **3 A** continuous current must be maintained for the 24 V DC connections.

For the internal bus modules of type **SK CU4-...** there is a limit of **1 A**. In case of doubt, the 24 V power supply should not be looped through and *each device should be supplied by a separate spur cable*.

Otherwise, interruption of the bus communication and destruction of the module are probable.

If signals from 24 V sensors are continuously required, up to two sensors can be connected to an SK CU4-... Alternatively, we recommend connection of the sensors to the mains unit of the frequency inverter, in order to reduce the current load on the 24 V bus supply.

2.3 PE connection

The connection unit of the frequency inverter (SK TI4-...) is equipped with two PE connections.

One of the two PE connections is used to create the **protective earthing**.

The second PE connection is used to create a **functional earthing**.

The connection unit of the optional module (SK TI4-TU-...) is equipped with a PE connection. The functional earthing must be provided via this PE connection if the module is separate from the frequency inverter and installed on a poorly conducting surface (e.g. the wall of a building) and there is therefore no proper contact to the earthing of the system.

If the optional module is mounted directly on the frequency inverter, connection of the functional earthing in the frequency inverter connection unit is sufficient.

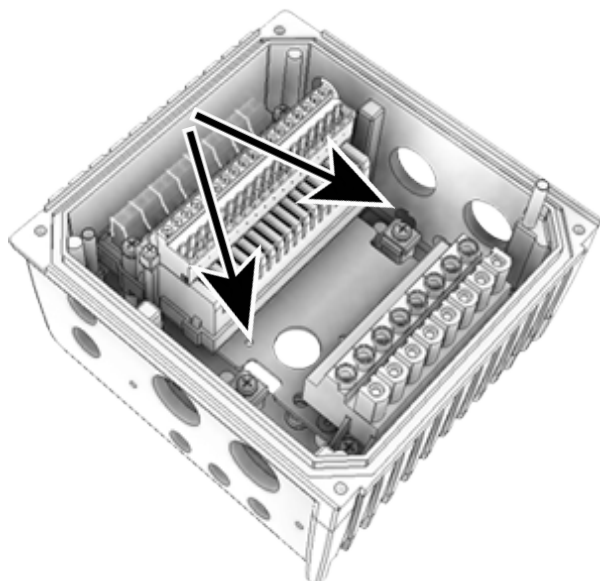

Frequency inverter connection unit (SK TI4-...)

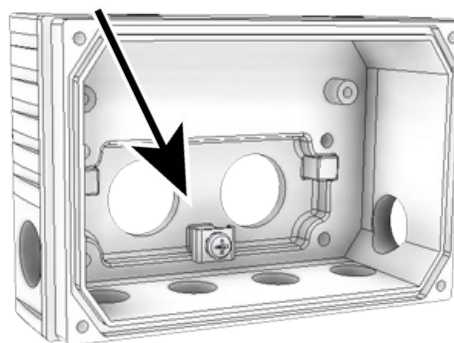

Connection unit of optional module SK TI4-TU-...

Protective earthing

- Installation of PE parallel to the mains cable (L1, L2/N, L3)
- PE with same cross section as the mains cable
- Connection via one of the two PE connection points in the connection unit

Functional earthing:

- PE connection cable to earth HF interference
- Thin conductor flexible wire, cross section 10 mm²
- Maximum length 3 m
- Connection via the second PE connection point in the connection unit
- Large area connection of the system PE, for example with pipe clips.

NOTICE

Functional earthing

Connection of the functional earthing must be made to a large, good conduction area (if necessary, strip the paint from painted areas at the connection point).

Otherwise the functional earthing will have no effect.

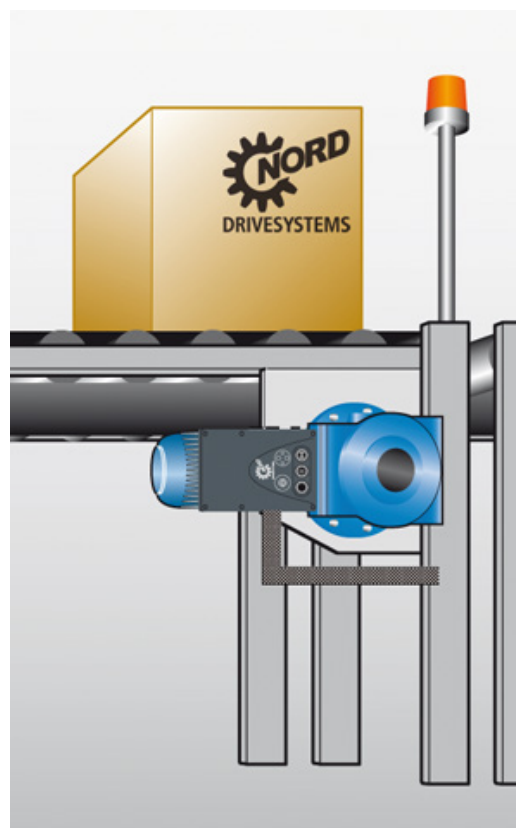

As of the transfer point of the functional earthing into the system, an equalised potential must be ensured within the system.

This is achieved with an earthing system, such as is described in section "Earthing, wiring recommendations"

2.4 Bus connection

2.4.1 System bus

NORD devices such as frequency inverters and field bus modules communicate via the so-called system bus. Physically, the system bus is based on CAN and communicates via a CANopen protocol.

Integration of the components into the system bus does not require any specific knowledge of the bus on the part of the user.

Only the proper physical configuration of the bus system and if necessary the correct addressing of the participants need to be taken into account by the user. A termination resistor must always be set at the physical ends of the system bus.

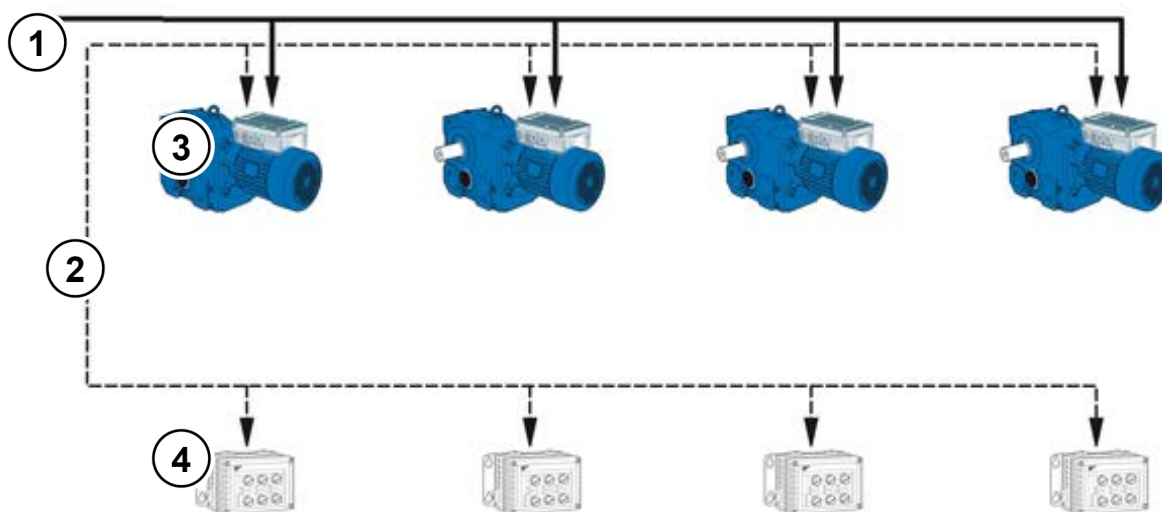

No.	Type
1	Mains connection
2	System bus cable (CAN_H, CAN-L, GND)
3	Frequency inverters
4	Options <ul style="list-style-type: none"> • Bus modules • IO Extensions • CANopen rotary encoder

Terminal	Meaning
77	System bus+ (CAN H)
78	System bus- (CAN L)
40	GND (Reference potential)
Terminal numbers may differ (depending on the device)	

NOTICE

Communication interference

To minimise the risk of communication interference, the **GND –potentials** (Terminal 40) of all GNDs which are linked via the system bus GND **must be connected together**. The shield of the bus cable must also be connected to PE at both ends.

Physical structure

standard	CAN
cable, specification	2x2, twisted pair, shielded, stranded wires, conductor cross-section $\geq 0.25 \text{ mm}^2$ (AWG 23), impedance app. 120Ω
bus length	max. 20 m total expansion max. 20 m between 2 nodes,
structure	preferably linear structure
stub	possible (max. 6 m)
terminator	120Ω , 250 mW at both ends of a system bus (with FI or SK xU4-... via DIP-switch)
baud rate	250 kBaud - preset

The signals CAN_H and CAN_L must be made through a twisted pair of wires. The connection of the GND potential via the second pair of wires.



Further details are described in the frequency inverter manual ([BU0200](#)).