

## SK BRW4-1-200-100

Part number: 275 273 308

External brake resistor for direct wall mounting of decentralised frequency inverters



Only qualified electricians are allowed to install and commission the module. An electrician is a person who, because of their technical training and experience, has sufficient knowledge with regard to

- switching on, switching off, isolating, earthing and marking power circuits and devices,
- proper maintenance and use of protective devices in accordance with defined safety standards.

### **DANGER!**

#### **Danger of electric shock**

The frequency inverter continues to carry hazardous voltages for up to 5 minutes after it was switched off.

- Work must not be carried out unless the device has been disconnected from the voltage and at least 5 minutes have elapsed since the mains was switched off!

### **CAUTION**

#### **Danger of burns**

The module and all other metal components can heat up to temperatures above 70 °C.

Sufficient cooling time must be allowed for when working on the components in order to avoid injuries (local burns) to parts of the body coming into contact with the components.

In order to avoid damage to neighbouring objects, sufficient clearance must be maintained during installation.

### **NOTICE**

#### **Validity of this document**

This document is only valid in combination with the operating instructions for the relevant frequency inverter. Safe commissioning of this module and the frequency inverter depends on the availability of this information.

Technical Information / Datasheet	SK BRW4-1-200-100			
Brake resistor	TI 275273308	1.0	4117	en

### Scope of delivery

Module		
1 x	<b>Braking resistor</b>	Incl. guard (metal grating)
2 x	<b>Mounting bracket</b>	BRW
4 x	<b>Fastening screw</b>	M4x6
1 x	<b>Connection reduction</b>	M25 / M20, brass
1 x	<b>Cable gland</b>	M20 x 1.5 incl. sealing insert, brass
1 x	<b>Connection cables</b>	3-wire
1 x	<b>Protective sleeve</b>	1.0 m
1 x	<b>Sealing ring</b>	M20 with 3x4 mm aperture



Similar to illustration

### Field of use

Dynamic braking (frequency lowering) of a three-phase motor via a frequency inverter results in generator braking energy that – depending on the application case – is dissipated by a braking resistor. This superfluous energy is transformed into heat.

The braking resistor is designed for the NORDAC *BASE* SK 180E and NORDAC *FLEX* SK 200E series of units and depends on the mains voltage and the power.



Similar to illustration

**Technical Data**
*Electrical data*

<b>Number of leads</b>		3
<b>Resistance (GYADU)</b>	Ω	200

<sup>1)</sup> The value given applies to a single use within 120 s.

<b>Max. continuous power</b> <b>P<sub>n</sub></b>	W	100
<b>Energy consumption</b> <b>P<sub>max</sub></b> <sup>1)</sup>	kWs	2.2

*General*

<b>Temperature range</b>	°C	0 ... 40 (100 % duty cycle/S1) 0 ... 50 (70 % duty cycle/S3)
<b>Tightening torque</b>		
Screws		0.6 – 1.2
Cable gland M20		1.5 – 2.0
Extension M16/M20		1.5 – 2.0
<b>Weight</b>	kg	0.7

<b>Certifications</b>	CE, UR, RoHS
<b>Protection class</b>	IP67
<b>Mounting</b> <sup>1)</sup>	
Mounting bracket	2 x M4 x 6 (size 7)

<sup>1)</sup> included in the scope of supply

*Dimensions*

<b>Envelope dimensions [mm]</b>	W x H x D	212 x 94 x 36
<b>Fixing dimensions [mm]</b>	W	184
<b>Cable / line [mm]</b>		
Flexible strand	L	1200
Wire end sleeve	L	10

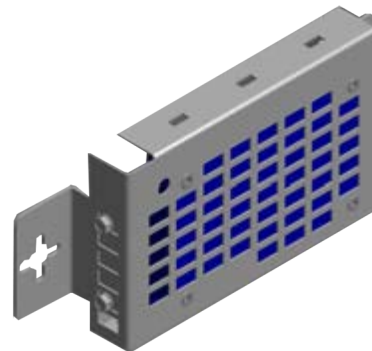
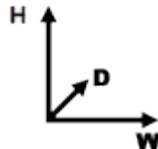
*Connections*

Name	PE connection	B-	B+
<b>Cross section / type</b>	AWG 14/19		
<b>Wire colour</b>	Green	Yellow	White
<b>Terminal label</b>	PE	Power terminal B-	Power terminal B+
<b>Tightening torque</b>			
SK 1x0E	0.5 – 0.6 Nm		
SK 2xxE	1.2 – 1.5 Nm		

**Frequency inverter assignment**
** Information**
**Overview in the manual**



The braking resistors provided by the NORD DRIVESYSTEMS Group are directly tailored to the individual frequency inverters. However, when external braking resistors are being used, it is usually possible to select between 2 or 3 alternatives.

For detailed information, please refer to chapter  Electric data for brake resistors of the respective frequency inverter manual "Further documentation and software: [www.nord.com](http://www.nord.com)".

### Installation

<b>Installation location</b>	Direct installation on the wall, with connecting cable for connection to a decentralised frequency inverter: <ul style="list-style-type: none"> <li>In the vicinity of the frequency inverter</li> </ul>
<b>Installation orientation</b>	any
<b>Fastening</b>	With screw fastenings <ul style="list-style-type: none"> <li>Screws for wall mounting are not supplied</li> </ul>

### Installation steps



1.	<p>Installing the frequency inverter</p> <p>The frequency inverter is already installed on the wall or the motor.</p>	
2.	<p>Installing the mounting bracket</p> <p>Fasten the two mounting brackets with the 4 supplied M4 screws to the right and to the left side of the brake resistor.</p> <ul style="list-style-type: none"> <li>Fasten laterally to the brake resistor with two of the four supplied M4 fastening screws.</li> </ul> <p>Then fasten the brake resistor directly on the wall or the mounting surface in a correct manner with 2 fastening screws to be provided separately.</p> <ul style="list-style-type: none"> <li>1 screw for each mounting bracket</li> </ul>	
3.	<p>Route the connecting cable into the frequency inverter through one of the M256 openings.</p> <ul style="list-style-type: none"> <li><b>Caution:</b> Replace the clamping seal of the cable gland with the black sealing insert</li> <li>Fit the M25/M20 cable gland reduction (preferably option slot 3AR, alternatively 3AL)</li> <li>Insert the connecting cable through the M20 cable gland</li> <li>Route the three leads of the cable through the black sealing insert</li> <li>Then route the leads into the terminal box/housing of the frequency inverter</li> <li>Screw an M20 cable gland into the M25/M20 cable gland reduction</li> </ul> <p>Make sure the gland is tight and tighten it to the specified torque (see  Technical Data – General).</p>	

4. Connect the connecting cable to the respective terminal strip or the terminals of the frequency inverter.
- ① Green/yellow lead ⇔ PE
  - ② White lead ⇔ B-
  - ③ Grey lead ⇔ B+
- Connect the PE lead to the PE lug of frequency inverter inside the terminal box or at the housing.
- Please heed the specified tightening torques; refer to  Technical Data – Connections.





## Parameters

Frequency inverter: The following parameters of the frequency inverter have to be set for optimum brake resistor operation. For details, refer to the frequency inverter manual  "Further documentation and software: [www.nord.com](http://www.nord.com)".

Parameters	Meaning	Remarks
P556	Braking resistor	Value of the brake resistance for the calculation of the maximum brake power to protect the resistor. <ul style="list-style-type: none"> <li>The error I<sup>2</sup>t limit (E003.1) is triggered. Further details  in P737.</li> <li>The error I<sup>2</sup>t limit (E003.1) is triggered. Further details  in P737.</li> </ul>
P557	Braking resistor type	Continuous power (nominal power) of the resistor, to display the actual utilisation in P737. For a correctly calculated value, the correct value must be entered into P556 and P557. <ul style="list-style-type: none"> <li>0.00 = Off, monitoring disabled</li> </ul>
P737	Usage rate brake res.	This parameter provides information about the actual degree of modulation of the brake chopper or the current utilisation of the braking resistor in generator mode. <ul style="list-style-type: none"> <li>Depending on the settings of parameters P556 and P557.</li> <li>The resistance power is displayed if both parameters are set correctly.</li> </ul>

## Error messages

Error messages of the braking resistor – the current or the archived message of the last fault – can be retrieved by way of the information parameters Actual fault P700 and Last fault P701 from the error memory of the frequency inverter. For details, refer to the frequency inverter manual  "Further documentation and software: [www.nord.com](http://www.nord.com)".

Error (E030/E050)	Meaning	Remarks
3.1	I <sup>2</sup> t overcurrent limit	Brake chopper: I <sup>2</sup> t limit has been triggered, 1.5-fold value for 60 s reached (  P556, P557) <ul style="list-style-type: none"> <li>Avoid overcurrent in brake resistance</li> </ul>
5.0	Overvoltage UZW	Link circuit voltage too high <ul style="list-style-type: none"> <li>Check the function of the connected braking resistor (broken cable)</li> <li>Resistance value of connected braking resistor too high</li> </ul>

**Wiring diagram**

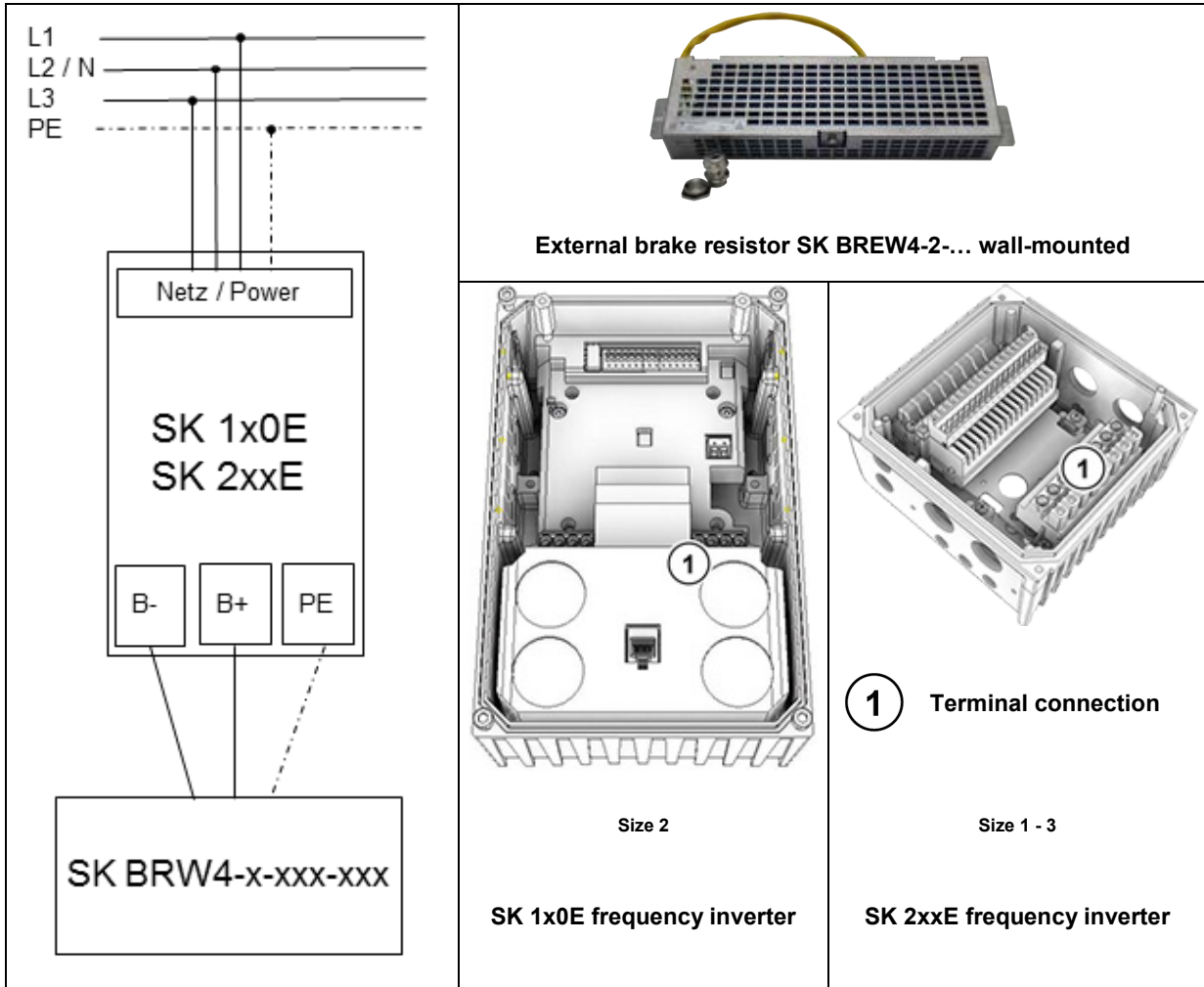

Further documentation and software: [www.nord.com](http://www.nord.com)

Document	Name
<a href="#">BU_0180</a>	SK 180E – SK 190E frequency inverter manual

Document	Name
<a href="#">BU_0200</a>	SK 200E frequency inverter manual