

CANopen

ETHERNET
POWERLINK

EtherCAT

DeviceNet

EtherNet/IP

PROFI[®]
BUS

PROFI[®]
NET

Modbus

INTERBUS

PROFIsafe

RS282/485

ASi[®]
INTERFACE

BU 2300 – en

EtherCAT bus interface

Supplementary manual options for NORD - Frequency Inverters

DRIVESYSTEMS



Table of Contents

1	Introduction	6
1.1	General	6
1.1.1	Documentation	6
1.1.2	Document History	6
1.1.3	Copyright notice	6
1.1.4	Publisher	6
1.1.5	About this manual	7
1.2	Other applicable documents	7
1.3	Presentation conventions	7
1.3.1	Warning information	7
1.3.2	Other information	7
1.3.3	Text markings	8
1.3.4	List of abbreviations	9
2	Safety	10
2.1	Intended use	10
2.2	Selection and qualification of personnel	10
2.2.1	Qualified personnel	10
2.2.2	Qualified electrician	10
2.3	Safety information	11
3	EtherCat basics	12
3.1	Characteristics	12
3.2	Topology	13
3.3	Bus protocol	14
3.4	Hot-Connect function	14
4	NORD system bus	15
4.1	NORD system bus participants	16
4.2	Access to parameters and control options	17
4.2.1	Access via the NORD SimpleBox	17
4.2.2	Access via the NORD ParameterBox	17
4.2.3	Access via NORDCON software	18
4.3	Remote maintenance	19
5	Initial setup	20
5.1	Connecting the bus interface	20
5.2	Integration into the bus master	21
5.2.1	Installing the device description file	21
5.2.2	Automatic device detection	21
5.2.3	Configuration of process data	22
5.2.4	EtherCAT field bus address	22
5.3	Example: Commissioning the EtherCAT bus module	23
6	Data transmission	25
6.1	Introduction	25
6.1.1	Process data	25
6.1.2	Parameter data	25
6.2	NMT status machine	26
6.3	Transfer of process data	26
6.3.1	Control word	27
6.3.2	Status word	28
6.3.3	Frequency inverter status machine	29
6.3.4	Setpoints and actual values	33
6.3.5	Process data telegrams	35
6.4	Parameter data transmission	36
6.4.1	EtherCAT parameters (CoE directory)	37
6.4.2	SDO error codes	38
6.5	Example of setpoint specification	39

7	Parameters	40
7.1	Parameter setting on the bus interface	40
7.1.1	NORD standard parameters	41
7.1.2	EtherCAT standard parameters	43
7.1.3	NORD information parameters	43
7.1.4	EtherCAT information parameters	47
7.2	Parameter settings on the frequency inverter	48
8	Error monitoring and error messages	50
8.1	Bus operation monitoring function.....	50
8.2	Resetting error messages	52
8.3	Handling of errors in the bus interface	53
8.3.1	Error Groups.....	53
8.3.2	Status word from the frequency inverter.....	53
8.4	Error messages.....	55
9	Appendix	56
9.1	Repair information.....	56
9.2	Service and commissioning information.....	56
9.3	Documents and software	57

List of illustrations

Figure 1: Linear topology (example).....	13
Figure 2: Tree topology with switch (example)	13
Figure 3: EtherCAT telegram.....	14
Figure 4: Example of the structure of a NORD system bus	15
Figure 5: Remote maintenance via Internet (schematic diagram)	19
Figure 6: NMT status machine.....	26
Figure 7: Frequency inverter status machine.....	29
Figure 8: Examples of monitoring parameter settings – SK TU4 bus interface	51
Figure 9: Examples of monitoring parameter settings – SK TU3 bus interface	51

1 Introduction

1.1 General

1.1.1 Documentation

Name: **BU 2300**
 Material number **6082302**
 Series: **Field bus system EtherCAT®**

1.1.2 Document History

Issue	Order number	Software version	Remarks
BU 2300 , October 2016	6082302/ 4116	V 1.8 R0	<ul style="list-style-type: none"> Combination of manuals BU 0270 EN, July 2010, Part number 607 2701 / 2610 and BU 0570 EN, January 2012, Part number 607 5701 / 0312 Extensive revision
BU 2300 , September 2019	6082302/ 3619	V 1.8 R5 (TU4) V 1.8 R2 (TU3)	<ul style="list-style-type: none"> Various corrections

1.1.3 Copyright notice

As an integral component of the device or the function described here, this document must be provided to all users in a suitable form.

Any editing or amendment or other utilisation of the document is prohibited.

1.1.4 Publisher

Getriebebau NORD GmbH & Co. KG

Getriebebau-Nord-Straße 1
 22941 Bargteheide, Germany
<http://www.nord.com/>

Tel.: +49 (0) 45 32 / 289-0

Fax: +49 (0) 45 32 / 289-2253

1.1.5 About this manual

This manual is intended to assist you in the setup of bus interfaces EtherCAT® from Getriebebau NORD GmbH & Co. KG in a field bus system. It is intended for all qualified electricians who plan, install and set up the field bus system (📖 Section 2.2 "Selection and qualification of personnel"). The information in this manual assumes that the qualified electricians who are entrusted with this work are familiar with the technology of the field bus system and programmable logic controllers (PLC).

This manual only contains information and descriptions of bus interfaces and frequency inverters manufactured by Getriebebau NORD GmbH & Co. KG. It does not contain any descriptions of the controllers and the necessary software for other manufacturers.

EtherCAT® is a registered trademark.

1.2 Other applicable documents

This manual is only valid in combination with the Technical Information for the bus interface which is used and the operating instructions for the relevant frequency inverter. Only these documents contain all of the information that is required for safe commissioning of the bus interface module and the frequency inverter. A list of the documents can be found in 📖 Section 9.3 "Documents and software".

The "Technical Information" (TI) for the bus interface and the manuals (BU) for the NORD frequency inverters can be found under www.nord.com.

1.3 Presentation conventions

1.3.1 Warning information

Warning information for the safety of the user and the bus interfaces are indicated as follows:

⚠ DANGER

This warning information warns against personal risks, which may cause severe injury or death.

⚠ WARNING

This warning information warns against personal risks, which may cause severe injury or death.

⚠ CAUTION

This warning information warns against personal risks, which may cause slight or moderate injuries.

NOTICE

This warning warns against damage to material.

1.3.2 Other information

i Information

This information shows hints and important information.

1.3.3 Text markings

The following markings are used to differentiate between various types of information:



Text

Type of information	Example	Marking
Instructions	1st 2nd	Instructions for actions whose sequence must be complied with are numbered sequentially.
Bullet points	•	Bullet points are marked with a dot.
Parameters	P162	Parameters are indicated by the prefix "P", a three-digit number and bold type.
Arrays	[-01])	Arrays are indicated by square brackets.
Factory settings	{ 0,0 }	Factory settings are indicated by curly brackets.
Software descriptions	"Cancel"	Menus, fields, buttons and tabs are indicated by quotation marks and bold type.

Numbers

Type of information	Example	Marking
Binary numbers	100001b	Binary numbers are indicated by the suffix "b"
Hexadecimal numbers	0000h	Hexadecimal numbers are indicated by the suffix "h"

Symbols used

Type of information	Example	Marking
Cross-reference	 Section 4 "NORD system bus"	Internal cross-reference A mouse click on the text calls up the stated point in the document.
	 Supplementary manual	External cross-reference
Hyperlink	http://www.nord.com/	References to external websites are indicated in blue and underlined. A mouse click calls up the website.

Type designations

Designation	Description
SK 1x0E	Series SK 180E frequency inverters
SK 2xxE	Series SK 200E frequency inverters
SK 2x0E-FDS	Series SK 250E-FDS frequency inverters
SK 5xxE	Series SK 500E frequency inverters
SK 54xE	SK 540E and SK 545E frequency inverters

1.3.4 List of abbreviations

Abbreviations used in this manual

Abbreviation	Meaning
AG	Absolute encoder
ASIC	Application-specific Integrated Circuit
Bus module	Bus module
CoE	CAN over EtherCAT
DIN	Digital input
DIP	Dual In-Line Package (= double row housing), compact switch block
DO	Digital output
DS	Device state (status)
EMC	Electromagnetic compatibility
I / O	Input/Output
FI	Frequency inverters
IGBT	Insulated-Gate Bipolar Transistor (semiconductor component)
IP	Internet protocol
I/O	Input, Output
IW	Actual value
LVDS	Low Voltage Differential Signalling, interface standard for high speed data communication
NMT	Network Management
PDO	Process Data Object
PLC	Programmable Logic Control (PLC)
PZD	Process data
RO	Read Only
Rx	Receive
SDO	Service Data Object
SPI	Serial Peripheral Interface
PLC	Programmable Logical Controller
STR	String value
STW	Control word
SW	Setpoint
TCP	Transmission Control Protocol
Tx	Transmit
U8 (U16, U32)	8 Bit (16 Bit, 32 Bit) unsigned, without prefix
USS	Universal serial interface
XML	Extensible Markup Language
ZSW	Status word

2 Safety

2.1 Intended use

EtherCAT bus interfaces from Getriebebau NORD GmbH & Co. KG are interfaces for EtherCAT field bus communication, which may only be used in the following frequency inverters from Getriebebau NORD GmbH & Co. KG.

Bus interface	Frequency inverter
SK TU3-ECT	SK 500E series
SK TU4-ECT	SK 180E and SK 200E series
SK TU4-ECT-C	
SK CU4-ECT	
SK CU4-ECT-C	

EtherCAT bus interfaces from Getriebebau NORD GmbH & Co. KG are used for communication by the frequency inverter with a PLC in an EtherCAT field bus system provided by the operator.

Any other use of the bus interfaces is deemed to be incorrect use.

2.2 Selection and qualification of personnel

The bus interface may only be installed and started up by qualified electricians. These must possess the necessary knowledge with regard to the technology of the field bus system, as well as configuration software and the controller (bus master) which are used.

In addition, the qualified electricians must also be familiar with the installation, commissioning and operation of the bus interfaces and the frequency inverters as well as all of the accident prevention regulations, guidelines and laws which apply at the place of use.

2.2.1 Qualified personnel

Qualified personnel includes persons who due to their specialist training and experience have sufficient knowledge in a specialised area and are familiar with the relevant occupational safety and accident prevention regulations as well as the generally recognised technical rules.

These persons must be authorised to carry out the necessary work by the operator of the system.

2.2.2 Qualified electrician

An electrician is a person who, because of their technical training and experience, has sufficient knowledge with regard to

- Switching on, switching off, isolating, earthing and marking power circuits and devices,
- Proper maintenance and use of protective devices in accordance with defined safety standards.
- Emergency treatment of injured persons.

2.3 Safety information

Only use bus interfaces and frequency inverters from NORD DRIVESYSTEM Group for their intended purpose,  Section 2.1 "Intended use".

To ensure safe operation of the bus interface, observe all of the instructions in this manual, and in particular the warning information in the other applicable documents,  Section 9.3 "Documents and software".

Only commission bus interfaces and frequency inverters in their technically unchanged form and not without the necessary covers. Take care that all connections and cables are in good condition.

Work on and with bus interfaces and frequency inverters must only be carried out by qualified personnel,  Section 2.2 "Selection and qualification of personnel".

3 EtherCat basics

3.1 Characteristics

EtherCAT (**E**thernet **C**ontrol **A**utomation **T**echnology) is a real time Ethernet. It uses standard frames and the physical layers from the Ethernet standard IEEE 802.3 EtherCAT is published in the standard IEC 61158.

Each bus participant only takes the data which are intended for it while the telegram which is sent by the bus master passes through it. Output data is inserted into the telegram in the same way. At the same time, the telegram is forwarded with a slight delay (a few nanoseconds). The bus participant recognises the commands which are intended for it and executes these. The last bus participant returns the completely processed telegram, so that it can be sent to the controller by the first bus participant as a response telegram.

Addressing of the EtherCAT bus participant is not necessary; this is carried out automatically by the bus master (PLC) according to the physical connection sequence on the bus.

Performance description

Standards	IEC 61158, IEC 61784, ISO 15745, SEMI E54.20
Possible number of bus participants	65,535
Transfer rate	100 MBit (Fast Ethernet, Full Duplex)
Update time	1000 FI axes (each with 8 Byte input and output data) in 1 ms
Wiring	Standard Ethernet cable CAT5 or better
Cable length	Max. 100 m between two nodes

3.2 Topology

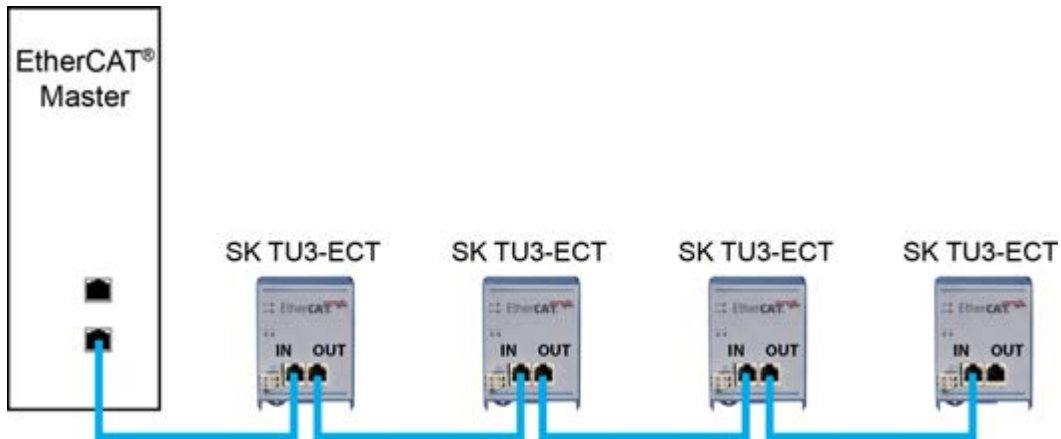

Figure 1: Linear topology (example)

EtherCAT bus interfaces from Getriebebau NORD GmbH & Co. KG are connected in a linear structure.

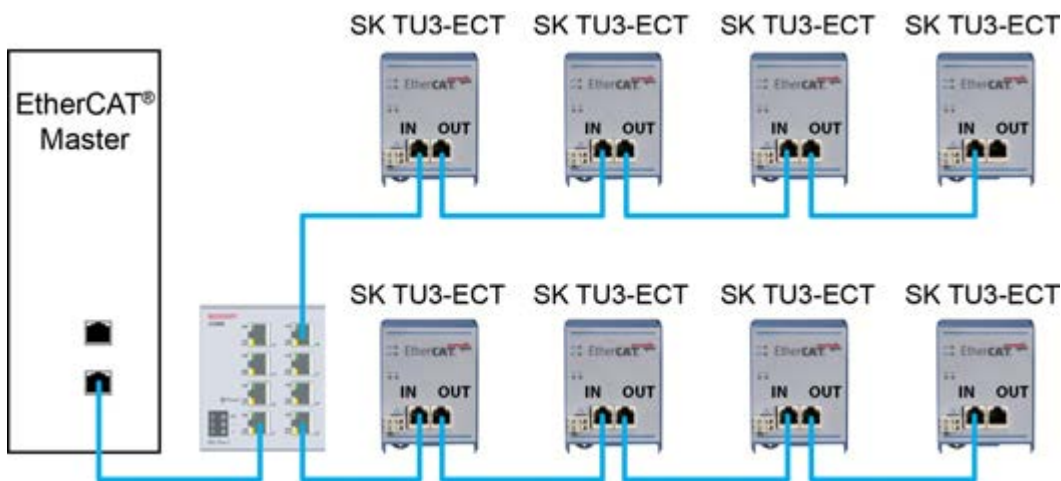

Figure 2: Tree topology with switch (example)

Other topologies such as star or tree topologies can be implemented by including switches. The bus interfaces are then connected in a linear structure, e.g. in a branch of a tree structure.

3.3 Bus protocol

EtherCAT application data are embedded in the standard Ethernet frames. For the transfer of process data, an EtherCAT frame is identified with the label "0x88A4" in the type field "Ethertype".

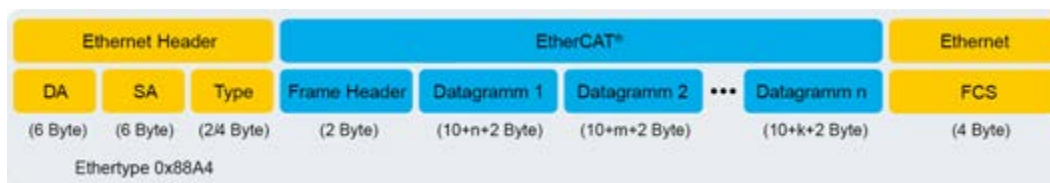

Figure 3: EtherCAT telegram

	Designation	Description
Ethernet Header	DA	Destination Address = Destination address of the EtherCAT frame
	SA	Source Address = source address of the EtherCAT frame
	Type	Type of EtherCAT frame (Ethertype 0x88AB)
Frame Header	—	Information about the length of datagrams within the EtherCAT frame and type of the datagram
Ethernet	FCS	Checksum for the EtherCAT frame

The EtherCAT telegram may consist of several datagrams (EtherCAT commands). The datagram specifies which access the bus master may carry out in the bus system (read, write, read and write, access to one or more bus participants). Each datagram addresses a certain range of the up to 4 Gigabyte logical process image. When the bus system is started up, each bus participant is allocated one or more unique addresses. Several bus participants with an address in the same range can therefore be accessed with a single datagram.

See  Section 6 "Data transmission" for detailed information.

3.4 Hot-Connect function

In EtherCat, "Hot Connect" refers to the removal or addition of bus participants while the bus is in operation. This can be done by switching the bus participant off or on, or by disconnection or connection to parts of the network.

Normally, the EtherCAT master assigns the addresses to the bus participants according to their physical sequence on the field bus. Without the Hot Connect function, the controller would have to re-adapt the bus configuration each time that a bus participant is switched in or out.

Bus participants which are configured for the Hot Connect function must be uniquely identifiable. Because of this, bus participants can be removed or added individually or as a Hot Connect group at any time, without the need for modifying the PLC project. Several configuration levels of the EtherCAT field bus system can therefore be operated with a single PLC project.

The configuration is done by setting an address ("Second Address") via DIP switches ( Section 5.2.4 "EtherCAT field bus address"), which is read in when the bus interface is switched on.

Information

With firmware version V1.8 R0 and above, the assignment of the address can also be made via parameter **P160** "Second Address". The DIP switch setting has priority. The setting of parameter **P160** is only effective if the corresponding DIP switches are set to "0".

4 NORD system bus

Communication between the bus interface and frequency inverters from Getriebebau NORD GmbH & Co. KG is carried out via a separate NORD system bus. The NORD system bus is a CAN field bus; communication is via the CANopen protocol.

One or more frequency inverters in the field bus system can be accessed via a bus interface.

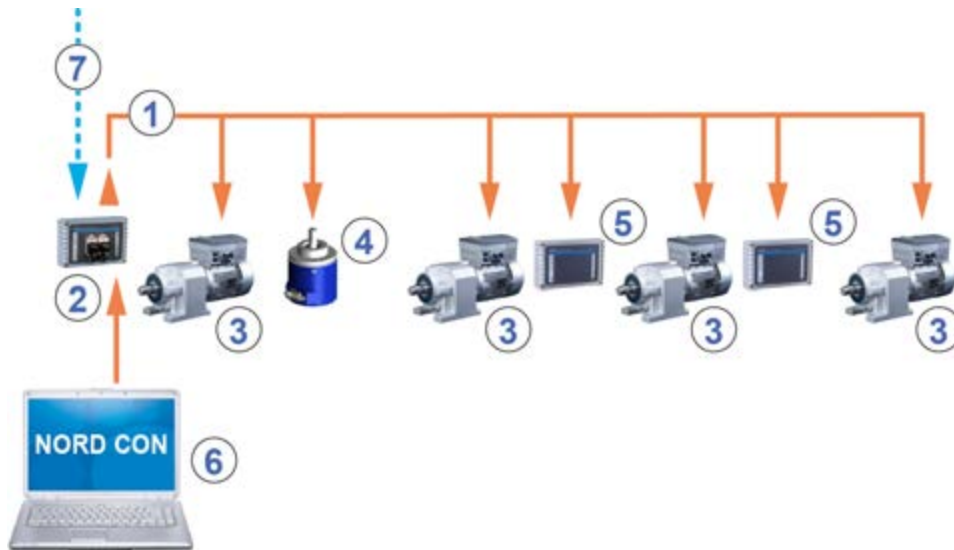



Figure 4: Example of the structure of a NORD system bus

Item	Description
1	NORD system bus (CAN field bus)
2	SK TU4 bus interface
3	Frequency inverter
4	Absolute encoder
5	Input/output extension SK TU4-IOE
6	NORD CON computer (on Windows® based PC, on which the NORD CON parameterisation and control software is installed)
7	Field bus

4.1 NORD system bus participants

Possible number of bus nodes on a system bus:

	Decentralised frequency inverters		Central frequency inverters	
	SK 1x0E	SK 2xxE	SK 500–535E	SK 54xE
Frequency inverter	4	4	8	8
Input/output extensions	8	8	—	16
CANopen encoder	4	4	8	8
Bus interface	1	1	1	1
NORD CON computer	1	1	1	1

All participants on the NORD system bus must be assigned a unique address (CAN ID). The address of the bus interface is pre-set at the factory and cannot be changed. Connected IO extensions must be assigned to the frequency inverters ( Technical Information/Data Sheet of the relevant IO extension). Depending on the device, the addresses of the frequency inverter and the connected absolute encoder can be set via the parameter **P515 CAN address** or via the DIP switches.

If absolute encoders are used, these must be assigned directly to a frequency inverter. This is carried out using the following equation:

Absolute encoder address = CAN ID of the frequency inverter + 1

This results in the following matrix:

Device	FI 1	AG1	FI 2	AG2	...
CAN-ID	32	33	34	35	...

The termination resistor must be activated on the first and last participant in the system bus ( Frequency inverter manual) The bus speed of the frequency inverter must be set to "250 kBaud" (**P514 CAN baud rate**) This also applies to any absolute encoders which are connected.

Information

SK 5xxE series, SK 511E and above

Setup of a system bus with SK 5xxE series devices is only possible for SK 511E devices and above and is made via their RJ45 sockets. It must be noted that the RJ45 sockets must have a 24 V DC supply in order to enable communication via the system bus ( Frequency inverter manual).

4.2 Access to parameters and control options

Communication by NORD control devices (SimpleBox and ParameterBox) and the NORD CON software with the bus interfaces and the frequency inverters on the NORD system bus is carried out via the USS protocol ( Manual [BU 0050](#))



Information

Access to bus interface parameters

- Access to bus interface parameters is only possible via the NORD CON software or the ParameterBox, not however via the SimpleBox (SK CSX-3...).
- Access to the parameters of a SK TU4 is possible via the NORD system bus by connection to a frequency inverter or also directly by connection to the RJ12 interface of the SK TU4.
- Access to the parameters of a SK CU4 is only possible via the NORD system bus (CANopen) by connection to a frequency inverter.

4.2.1 Access via the NORD SimpleBox

By connection of the SimpleBox ( Manual [BU 0040](#)) to a frequency inverter a **point-to-point USS bus communication** is established. The SimpleBox only communicates with the frequency inverter to which it is connected.

4.2.2 Access via the NORD ParameterBox

Access via the ParameterBox ( Manual [BU 0040](#)) can be obtained by several methods:

- Connection of the ParameterBox to a frequency inverter for **point-to-point USS bus communication**. The ParameterBox only communicates with the frequency inverter to which it is connected.
- Connection of the ParameterBox to a frequency inverter for **USS communication** with a maximum of 6 participants (5 devices plus ParameterBox). This requires an installed USS bus:
 - Wired,
 - Termination resistors set,
 - USS bus participants addressed.
- Connection of the ParameterBox to a bus interface or frequency inverter for **system bus communication (CANopen)** with a maximum of 6 participants (5 devices plus ParameterBox).

This requires an installed system bus:

- Wired,
- Termination resistors set,
- System bus participants addressed, USS addresses set to the factory setting ("0"). If the ParameterBox detects an active system bus, a USS address is automatically assigned to all of the participants which are detected.

Communication is via the USS protocol. The CANopen interface of the bus interface or the device with which the ParameterBox is connected acts as a gateway.

4.2.3 Access via NORDCON software

Access via the NORDCON software ( Manual [BU 0000](#)) can be obtained by several methods:

- Connection of the NORDCON computer to a frequency inverter for **point-to-point USS bus communication**. The NORDCON software only communicates with the frequency inverter to which it is connected.
- Connection of the NORDCON computer to a frequency inverter for **USS communication** with a maximum of 32 participants (31 devices plus ParameterBox). This requires an installed USS bus:
 - Wired,
 - Termination resistors set (only for RS485 connection. This is not necessary for an RS232 connection).



Information

USS address

It is not necessary to set a USS address.

- Connection of the NORDCON computer to a bus interface or frequency inverter for **system bus communication (CANopen)** with a maximum of 32 participants (31 devices plus NORDCON). This requires an installed system bus:
 - Wired,
 - Termination resistors set,
 - System bus participants addressed, USS addresses set to the factory setting ("0"). If the NORDCON software detects an active system bus, a USS address is automatically assigned to all of the participants which are detected.

Communication is via the USS protocol. The CANopen interface of the bus interface or the device with which the NORDCON software is connected acts as a gateway.

4.3 Remote maintenance

NORD bus interfaces are designed for remote maintenance via the field bus system. Devices which are connected to the bus interface and the NORD system bus (frequency inverters, I/O extensions) from Getriebebau NORD GmbH & Co. KG can also be accessed via LAN or Internet for maintenance purposes.

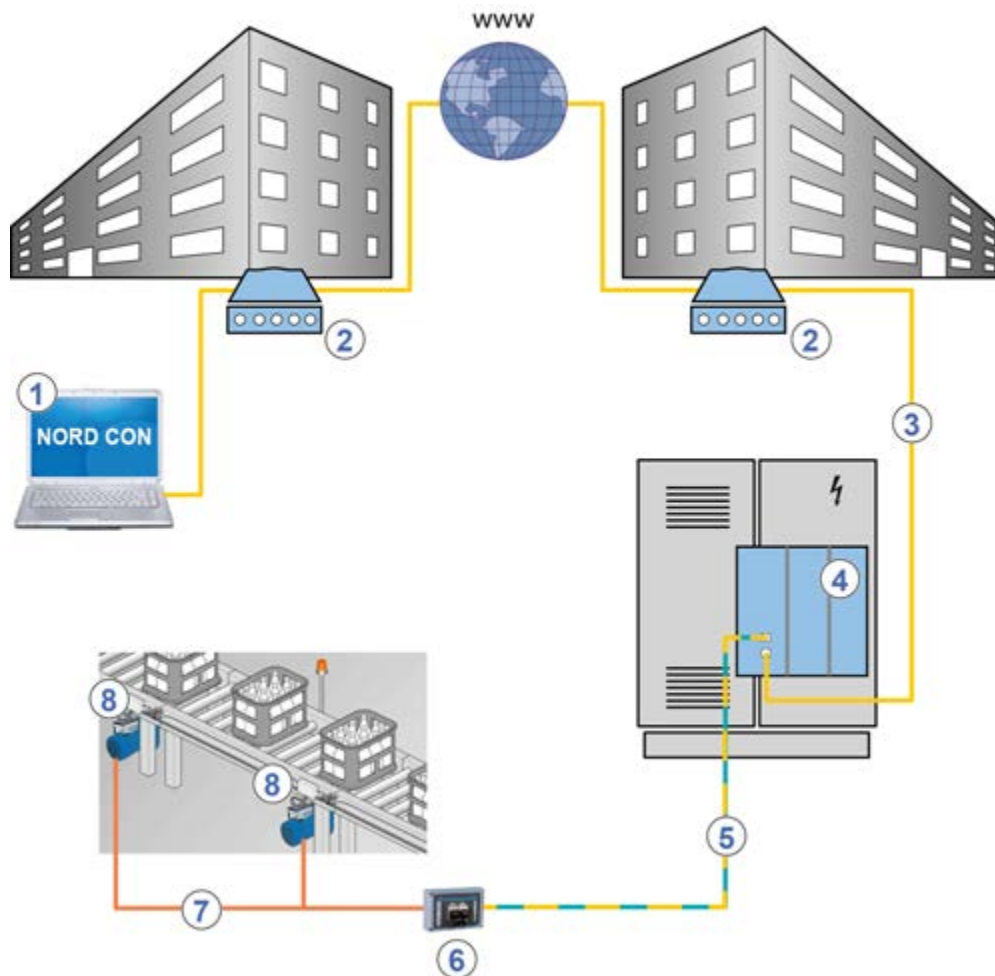



Figure 5: Remote maintenance via Internet (schematic diagram)

Item	Description
1	NORD CON software
2	Modem
3	LAN
4	Field bus gateway or bus master (PLC)
5	Field bus
6	Bus interface
7	NORD system bus
8	NORD- frequency inverter

5 Initial setup

The bus interface must be set up in order to commission the field bus system. This consists of the following work:

Type of work	Description 
Connect the bus interface to the frequency inverter	Section 5.1 "Connecting the bus interface"
Configure the control project	Section 5.2 "Integration into the bus master"
Assign the bus address	Section 5.2 "Integration into the bus master"
Make the required parameter settings	Section 7 "Parameters"

An example of the procedure for setting up the field bus system can be found at the end of this section ( Section 5.3 "Example: Commissioning the EtherCAT bus module").

Detailed information about EMC compliant installation can be found in the Technical Information [TI 80_0011](#) under www.nord.com

5.1 Connecting the bus interface



Information

Bus address via DIP switch

Before connecting the bus interface, read the information for setting the bus address in the technical information and in this manual ( Section). If the bus address is set with the DIP switches, this must be carried out before the bus interface is connected, as the DIP switches are no longer accessible after this.

Connection of the bus interface to the frequency inverter and the EtherCAT field bus is described in the corresponding technical information:

Bus interface	Frequency inverter	Documentation
SK TU3-ECT	SK 5xxE series	Technical Information/Data Sheet TI 275900180
SK TU4-ECT	SK 1x0E and SK 2xxE series	Technical Information/Data Sheet TI 275281117
SK TU4-ECT-C		Technical Information/Data Sheet TI 275281167
SK CU4-ECT		Technical Information/Data Sheet TI 275271017
SK CU4-ECT-C		Technical Information/Data Sheet TI 275271517

5.2 Integration into the bus master

The bus master must first be configured for communication with the bus interface (PLC project). The configuration must be produced with a software system for EtherCAT field bus systems, real time execution and diagnosis (e.g. "TwinCAT" from Beckhoff Automation GmbH & Co. KG).

5.2.1 Installing the device description file

The bus master needs a device description file so that the bus interface and the frequency inverter can be identified by the bus master during the bus scan. The currently valid device description file which is required for the configuration of the EtherCAT bus interface and the frequency inverter can be downloaded under the link

[NORDAC Options](#).

The file (e.g. "NORD_TU3_ECT.xml") contains a description of the device characteristics of the bus interface and its parameters as well as the parameters of the connected frequency inverter.

The characteristics of all bus interface types are described in the device description file. The relevant type must be selected in the EtherCAT configuration software.

File	Bus interface	Frequency inverter	Remarks
NORD_TU3_ECT.xml	SK TU3-ECT	SK 5xxE series	Connecting a frequency inverter
NORD_TU3_ECT_SYS.xml	SK TU3-ECT	SK 500E...SK 535E software version 3.0 R0	Connection of up to 4 frequency inverters
		SK 54xE software version 2.2 R0	
NORD_TU4_ECT.xml	SK CU4-ECT	SK 1x0E and SK 2xxE series	Connection of up to 4 frequency inverters, communication with SK 54xE frequency inverters via the NORD system bus is also possible.
	SK TU4-ECT		

Information

Number of connected frequency inverters

As delivered, the device description file is set to a connected frequency inverter (FI1) If several frequency inverters are connected, these must be set in the configuration software after installation of the device description file.

5.2.2 Automatic device detection

After installation of the device description file, the bus interface and the connected frequency inverters are automatically detected and uniquely identified by the configuration software in a bus scan. This is carried out via the parameters

- "Software Version",
- "Vendor ID" (NORD manufacturer code "00000538h") and
- "Product Code",

which are saved in the "CoE directory" ( Section 6.4 "Parameter data transmission").

The parameter "Product Code" is communicated to the bus master during the start-up phase of the field bus system. The bus master then adopts the settings from the device description file on the basis of this code.

5.2.3 Configuration of process data

The process data of the bus interface and the frequency inverter must be linked to the PLC variables in the configuration project. For detailed information about process data, please refer to  Section 6.3 "Transfer of process data".

5.2.4 EtherCAT field bus address

EtherCat bus interfaces do not need to be addressed. Addressing is performed automatically by the bus master (PLC) according to their physical sequence on the bus.

If the Hot Connect function is used, a unique address ("Second Address") must be assigned to the bus interface. The assignment is made with the DIP switches, with firmware version V1.8 R0 and above, this can also be made via parameter **P160 Second Address**. The DIP switch setting has priority. The setting of parameter **P160** is only effective if the corresponding DIP switches are set to "0".

The address is read out by the bus interface when the bus interface is connected to the power supply ("POWER ON").

The address which is set can be read out via the parameter **P181** ( Section).

Information

Arrangement in the bus system

Bus participants without the Hot Connect function must always be physically arranged at the beginning of the field bus system. No bus participant without this function may be located in the EtherCAT line after a bus participant with the Hot Connect function.

Requirement

- The EtherCAT field bus system has been installed and commissioned according to the manufacturer's instructions.

Procedure

1. Set the bus address ("Second Address") on the DIP switch,  Technical Information/Data Sheet.
2. Configure the bus interface for the Hot Connect function in the operator's EtherCAT configuration project.

5.3 Example: Commissioning the EtherCAT bus module



The following example contains an overview of the necessary steps for commissioning the bus interface in a EtherCAT field bus system. The example does not include any details of application-specific settings (motor data, control parameters, etc.).

Example:

Via a bus interface, 3 frequency inverters are to be independently controlled in positioning operation with a single speed and a single position specification.

Device type	Name	Connected motor	Characteristics
Bus interface SK TU4-ECT	BusBG ¹		
SK 2x5E frequency inverter	FI 1	4-pole/n=1390 rpm/50 Hz	Motor with CANopen absolute encoder AG1
SK 2x5E frequency inverter	FI 2	4-pole/n=1390 rpm/50 Hz	Motor with CANopen absolute encoder AG2
SK 2x5E frequency inverter	FI3 ¹	4-pole/n=1390 rpm/50 Hz	Motor with CANopen absolute encoder AG3

¹ The bus interface and frequency inverter FI3 are physically the last participants on the NORD system bus.

Communication	Step	Explanation	
NORD system bus	1	Before connecting the bus interface to the frequency inverter: Set the termination resistors.	
		Set DIP switch 1 (of 12) on the bus interface to the "ON" position.	
		Set DIP switch S2 on frequency inverter FI3 to the "ON" position.	
			All other DIP switches (termination resistors) must be in the "OFF" position.
	2	Set up system bus.	A 24 V supply is required! ( Technical Information for the bus interface)
	3	Set the system bus address of the frequency inverter	Preferably with the DIP switches ( BU 0200):
			FI1 Address "32"
			FI2 Address "34"
			FI3 Address "36"
			AG1 Address "33"
AG2 Address "35"			
		AG3 Address "37"	
		The address of the bus interface is pre-set and cannot be changed.	
4	Set the system bus baud rate.	Set "250 kBaud" on FI1 to FI3 as well as on AG1 to AG3.	

Communication	Step	Explanation	
	5	Set the parameters for system bus communication.	Set the following parameters on each frequency inverter:
			P509 3 (system bus)
			P510 , [-01] 0 (Auto)
			P510 , [-02] 0 (Auto)
			P543 , [-01] 1 (actual frequency)
			P543 , [-02] 10 (curr. Pos. Inc. LowWord)
			P543 , [-03] 15 (cur. Pos. Inc. HighWord)
			P546 , [-01] 1 (set point frequency)
			P546 , [-02] 23 (setp. Pos. Inc. LowWord)
P546 , [-03] 24 (set. Pos. Inc. HighWord)			
EtherCAT field bus	6	Set up the bus interface for field bus communication.	📖 Sections 5.1 "Connecting the bus interface" to 5.2 "Integration into the bus master"
			Set the following parameters on the bus interface (📖 Section 7.1.1 "NORD standard parameters"):
			P151 200 ms (Timeout external bus)
NORD system bus	7	Set the parameters for system bus monitoring.	Set the following parameters on each frequency inverter (📖 BU 0200)
			P120 , [-01] 1 (Auto) or 2 (monitoring active immediately)
	8	Check the system bus communication.	Check the display of the following information parameters on all frequency inverters (📖 BU 0200):
			P748 "System bus status"
			P740 , [-01] "Control word" (047Eh = "Ready for switch-on" ¹)
			P740 , [-02] "Setpoint 1"
			P741 , [-01] "Status word" (0B31h = "Ready for switch-on")
			P741 , [-02] "Actual value 1"
			Check the display of the following bus interface information parameters (📖 Section 7.1.3 "NORD information parameters"):
P173 "Module status"			
EtherCAT field bus	9	Check the field bus communication.	Check the display of the following bus interface information parameters (📖 Section 7.1.3 "NORD information parameters"):
			P173 "Module status"
			P740 "Process data Bus In"
			P177 "Process data Bus Out"

¹ On condition that the PLC has already sent the control word. Otherwise "0h" is displayed in the parameter.

6 Data transmission

6.1 Introduction

With the data communication between the frequency inverter (via the bus interface) and the bus master (PLC) process data and parameter data are exchanged.

6.1.1 Process data

- Process data are the control word and up to 5 setpoints, as well as the status word and up to 5 actual values. Control words and setpoints are communicated from the bus master to the frequency inverters. Status words and actual values are communicated from the frequency inverters to the bus master.
- Process data are necessary to control the frequency inverter.
- The transfer of process data is carried out cyclically with priority between the bus master and the frequency inverters.
- In the PLC the process data are stored directly in the I/O area.
- Process data are not saved in the frequency inverter.

 Section 6.3 "Transfer of process data".

6.1.2 Parameter data

- Parameter data are the setting values and device data for the bus interface and the connected frequency inverter.
- Transfer of the parameter data is carried out acyclically without priority.

6.2 NMT status machine

When the bus system is started up, the bus interface runs through the EtherCAT NMT status machine. The switch-over between the individual states is made via the bus master (PLC).

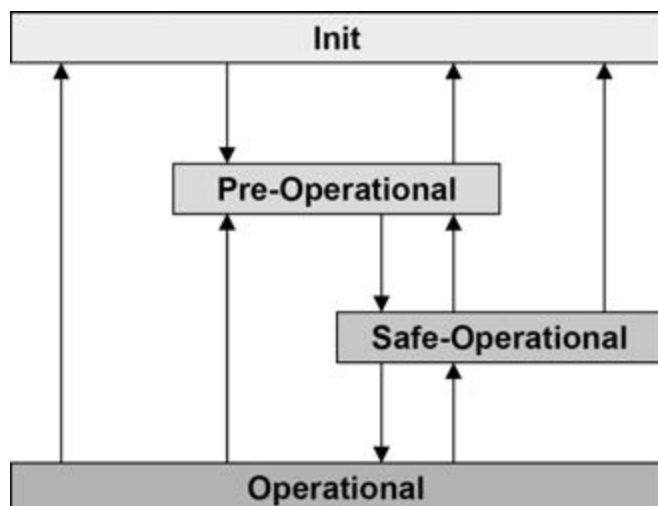

Figure 6: NMT status machine

The statuses of the EtherCAT field bus are displayed by the "RUN" LED on the bus interface.

Status	Description	LED "RUN" (green)
Init	Initialisation phase: <ul style="list-style-type: none"> • No communication of process data and parameters • Detection of devices possible with a field bus scan 	Off
Pre-Operational	Field bus running: <ul style="list-style-type: none"> • Parameter communication possible • No process data communication 	Flashes (cycle 0.4 s)
Safe-Operational	<ul style="list-style-type: none"> • Parameter communication possible • Limited communication of process data possible. Actual values are transmitted, setpoints are in the status "Safe" and are not evaluated 	Flashes once (single flash)
Operational	Normal operation: <ul style="list-style-type: none"> • Parameter communication active • Process data communication active 	Illuminates continuously



6.3 Transfer of process data

The control word (STW) and up to 3 setpoints (SW) are transferred from the bus master to the frequency inverter and the status word (ZSW) and up to 3 actual values (IW) are transferred from the frequency inverter to the bus master as process data (PZD).

The structure of EtherCAT process data is fixed and is determined by the device description file (📖 Section 5.2 "Integration into the bus master").

6.3.1 Control word

The control word (STW) is the first word of a process data telegram which is sent from the bus master to the frequency inverter (order telegram) To switch the drive unit to standby, the frequency inverter must be set to "Ready for switch-on" status by transfer of the first control command "047Eh" ("1000111110b").

Bit	Designation	Value	Control command	Priority ¹															
0	Ready for operation	0	Reverse with brake ramp, with voltage enabled at f=0 Hz (ready for operation)	3															
		1	Set the frequency inverter to standby.	5															
1	Disable voltage	0	Switch off the frequency inverter output voltage (the frequency inverter goes into the status "Switch-on block").	1															
		1	Cancel "Disable voltage"	—															
2	Emergency stop	0	Emergency stop with programmed emergency stop time. At f = 0 Hz voltage enable (the FI goes into "Switch-on block" status)	2															
		1	Cancel operating condition "Emergency stop"	—															
3	Enable operation	0	Block voltage: Switch off the frequency inverter output voltage (the frequency inverter goes into the status "Ready for switch-on").	6															
		1	Enable output voltage Acceleration of the frequency inverter to the present setpoint.	4															
4	Enable pulses	0	Acceleration encoder is set to zero; at f = 0 Hz no voltage enable (FI remains in "Operation enabled" status).	—															
		1	Enable acceleration encoder																
5	Enable ramp	0	Freeze the setpoint currently provided by the acceleration encoder (maintain frequency).	—															
		1	Enable setpoint on acceleration encoder																
6	Enable setpoint	0	Set the selected setpoint on the acceleration encoder to 0	—															
		1	Activate the selected setpoint on the acceleration encoder.																
7	Acknowledge the error (0→1)	0	With the switch from 0 to 1, inactive errors are acknowledged.	7															
		1	Note: If a digital input has been programmed for the "ack.fault" function, this bit must not permanently be set to 1 via the bus, as otherwise, flank evaluation would be prevented.																
8	Start function 480.11	0		—															
		1	Bus bit 8 of the control word is set  Parameter P480 in the frequency inverter manual.																
9	Start function 480.12	0		—															
		1	Bus bit 9 of the control word is set  Parameter P480 in the frequency inverter manual.																
10 ²	Control data valid	0	The transmitted process data are invalid.	—															
		1	The bus master transfers valid process data																
11 ³	Rotation right is on	0		—															
		1	Switch on rotation right.																
12 ³	Rotation left is on	0		—															
		1	Switch on rotation left (priority).																
13	Reserved																		
14	Parameter set Bit 0 On	0	<table border="1" data-bbox="730 1646 1165 1758"> <thead> <tr> <th>Bit 15</th> <th>Bit 14</th> <th>it activates the parameter set</th> </tr> </thead> <tbody> <tr> <td>0</td> <td>0</td> <td>Parameter set 1</td> </tr> <tr> <td>0</td> <td>1</td> <td>Parameter set 2</td> </tr> <tr> <td>1</td> <td>0</td> <td>Parameter set 3</td> </tr> <tr> <td>1</td> <td>1</td> <td>Parameter set 4</td> </tr> </tbody> </table>	Bit 15	Bit 14	it activates the parameter set	0	0	Parameter set 1	0	1	Parameter set 2	1	0	Parameter set 3	1	1	Parameter set 4	—
		Bit 15		Bit 14	it activates the parameter set														
0	0	Parameter set 1																	
0	1	Parameter set 2																	
1	0	Parameter set 3																	
1	1	Parameter set 4																	
1																			
15	Parameter set Bit 1 On	0		—															
		1																	



¹ If several control bits are set simultaneously, the priority stated in this column applies.

² The telegram is only interpreted as valid by the frequency inverter and the setpoints which are communicated via the field bus are only set if control bit 10 is set to 1.

³ If Bit 12 = 0, "rotational direction right ON" applies.
If Bit 12 = 1, "rotational direction left ON" applies, irrespective of Bit 11.

6.3.2 Status word

The status word (ZSW) is the first word of a process data telegram which is sent from the frequency inverter to the bus master (response telegram). With the status word, the status of the frequency inverter is reported to the bus master. As the response to the control word command "047Eh" the frequency inverter typically responds with "0B31h" ("101100110001b") and therefore indicates the status "Ready for switch-on".

Bit	Meaning	Value	Status message															
0	Ready to start	0																
		1	Initialisation completed, charging relay switched on, output voltage disabled															
1	Ready for operation	0	No switch-on command present, or there is a fault, of the command "Disable voltage" or "Emergency stop" is present, or the status is "Switch-on block".															
		1	There is a switch-on command and there is no fault. The inverter can be started with the command "Enable operation"															
2	Operation enabled	0																
		1	The output voltage is enabled; ramp of the frequency inverter up to the existing setpoint															
3	Fault	0																
		1	Drive unit defective and therefore "Not ready for operation". After acknowledgement, the frequency goes into status "Switch-on block".															
4	Voltage enabled	0	"Disable voltage" command present.															
		1																
5	Emergency stop	0	"Emergency stop" command present.															
		1																
6	Starting disabled	0																
		1	With the command "Standby" the frequency goes into status "Ready for switch-on".															
7	Warning active	0																
		1	Drive operation continues, no acknowledgement necessary															
8	Setpoint reached	0	Actual value does not correspond to the setpoint With use of POSICON: Setpoint position not reached.															
		1	Actual value matches the setpoint (setpoint reached) With use of POSICON: setpoint position has been reached															
9	Bus control active	0	Control on local device active															
		1	The master has been requested to take over control.															
10	Start function 481.9	0																
		1	Bus bit 10 of the status word is set  Parameter P481 in the frequency inverter manual.															
11	Rotation right is on	0																
		1	The frequency inverter output voltage has a right-hand rotation field.															
12	Rotation left is on	0																
		1	The frequency inverter output voltage has a left-hand rotation field.															
13	Start function 481.10	0																
		1	Bus bit 13 of the status word is set  Parameter P481 in the frequency inverter manual.															
14	Parameter set Bit 0 ON	0	<table border="1"> <thead> <tr> <th>Bit 15</th> <th>Bit 14</th> <th>parameter set, that is active</th> </tr> </thead> <tbody> <tr> <td>0</td> <td>0</td> <td>Parameter set 1</td> </tr> <tr> <td>0</td> <td>1</td> <td>Parameter set 2</td> </tr> <tr> <td>1</td> <td>0</td> <td>Parameter set 3</td> </tr> <tr> <td>1</td> <td>1</td> <td>Parameter set 4</td> </tr> </tbody> </table>	Bit 15	Bit 14	parameter set, that is active	0	0	Parameter set 1	0	1	Parameter set 2	1	0	Parameter set 3	1	1	Parameter set 4
		Bit 15		Bit 14	parameter set, that is active													
0	0	Parameter set 1																
0	1	Parameter set 2																
1	0	Parameter set 3																
1	1	Parameter set 4																
1																		
15	Parameter set Bit 1 On	0																
		1																

6.3.3 Frequency inverter status machine

The frequency inverter passes through a status machine. The changes between various states are triggered automatically or by control commands in the process data control word. The present status is returned in the process data status word.

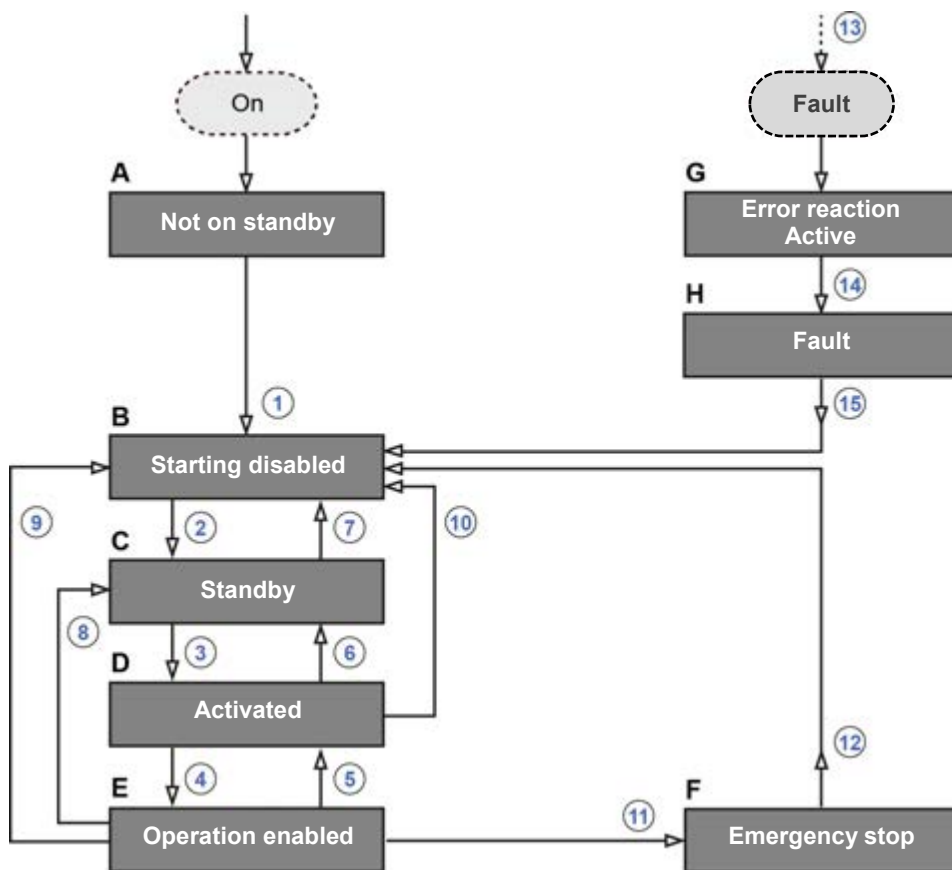

Figure 7: Frequency inverter status machine

Item	Meaning
A...H	Frequency inverter statuses (Table "Frequency inverter statuses")
1...15	Status transitions (Table "Status transitions")

Frequency inverter statuses

Status		Description
A	Not on standby	Initial state after switching on the frequency inverter. As soon as the loading relay engages, the frequency inverter automatically changes to the status "Switch-on block".
B	Switch-on block	Second status after switching on the frequency inverter, which can only be exited with the control command "Shut-down". The charging relay is switched on.
C	Standby	In this status, initialisation of the frequency inverter is complete. The output voltage is blocked.
		<div style="background-color: #e0e0e0; padding: 5px;">i Information</div> <p>During the initialisation process the response to a bus master telegram does not yet contain the response to the control command which has been issued. On the basis of the response from the bus participant, the control system must determine whether the control command has been executed.</p>
D	Activated	Frequency inverter ready for operation.
E	Operation enabled	The frequency inverter receives and processes setpoints.
F	Emergency stop active	Emergency stop function is being executed (the drive is stopped), the frequency inverter changes to the status "Switch-on block".
G	Error reaction active	If an error occurs, the frequency inverter changes to this status and all functions are blocked.
H	Fault	After processing of the response to the fault, the frequency inverter changes to this status, which can only be exited with the control command "Acknowledge fault".

Status transitions

Triggered status transition		Control command	Bit 7...0 of the control word ¹								
			7	6	5	4	3	2	1	0	
1	From "Not ready for switch-on" to "Switch on block"	—	—								
	Automatic activation of the charging relay										
2	From "Switch-on block" to "Ready for switch-on"	Shut down	X	X	X	X	X	1	1	0	
3	From "Ready for switch-on" to "Switched on"	Switch on	X	X	X	X	X	1	1	1	
4	From "Switched on" to "Operation enabled"	Enable operation	X	1	1	1	1	1	1	1	
	Output voltage is enabled										
5	From "Operation enabled" to "Switched on"	Disable operation	X	X	X	X	0	1	1	1	
	Output voltage is disabled										
6	From "Switched on" to "Ready for switch-on"	Shut down	X	X	X	X	X	1	1	0	
	Voltage enabled at "f = 0 Hz"										
7	From "Ready for switch-on" to "Switch-on block"	Disable voltage	X	X	X	X	X	X	0	X	
		Quick stop	X	X	X	X	X	0	1	X	
8	From "Operation enabled" to "Ready for switch-on"	Shut down	X	X	X	X	X	1	1	0	
9	From "Operation enabled" to "Switch on block"	Disable voltage	X	X	X	X	X	X	0	X	
10	From "Switched on" to "Switch on block"	Disable voltage	X	X	X	X	X	X	0	X	
		Quick stop	X	X	X	X	X	0	1	X	
11	From "Operation enabled" to "Emergency stop active"	Quick stop	X	X	X	X	X	0	1	X	
12	From "Emergency stop active" to "Switch on block"	Disable voltage	X	X	X	X	X	X	0	X	
13	Automatically, after the occurrence of a fault from any status	—	—								
14	Automatically after completion of the response to a fault	—	—								
15	End fault	Acknowledge error	0	X	X	X	X	X	X	X	X
			→								
			1	X	X	X	X	X	X	X	X

X = The bit status (0 or 1) is not important for achieving the status. Please also note the list of control bits, [Section 6.3.1 "Control word"](#).

¹ Complete list of control bits (Bit 0...15) [Section 6.3.1 "Control word"](#).

Information

Control bit 10

Control bit 10 "Control data valid" must always be set to 1. Otherwise the process data will not be evaluated by the frequency inverter.

Decoded frequency inverter statuses

Status	Status bit ¹						
	6	5	4	3	2	1	0
Not ready for switch-on	0	X	X	0	0	0	0
Starting disabled	1	X	X	0	0	0	0
Ready to start	0	1	1	0	0	0	1
Activated	0	1	1	0	0	1	1
Operation enabled	0	1	1	0	1	1	1
Fault	0	X	X	1	0	0	0
Error active	0	X	X	1	1	1	1
Emergency stop active	0	0	1	0	1	1	1

¹ Complete list of status bits (Bit 0...15)  Section 6.3.2 "Status word".

6.3.4 Setpoints and actual values

Setpoints (from the bus master to the frequency inverter) and actual values (from the frequency inverter to the bus master) are specified via the following parameters of the frequency inverter:

Direction of transmission	Process value	Parameters		
		SK 1x0E, SK 2xxE frequency inverters	SK 500E...SK 535E frequency inverters	SK 54xE frequency inverters
To bus interface	Setpoint 1	P546, Array [-01]	P546	P546, Array [-01]
	Setpoint 2	P546, Array [-02]	P547	P546, Array [-02]
	Setpoint 3	P546, Array [-03]	P548	P546, Array [-03]
	Setpoint 4	—	—	P546, Array [-04]
	Setpoint 5	—	—	P546, Array [-05]
From bus interface	Actual value 1	P543, Array [-01]	P543	P543, Array [-01]
	Actual value 2	P543, Array [-02]	P544	P543, Array [-02]
	Actual value 3	P543, Array [-03]	P545	P543, Array [-03]
	Actual value 4	—	—	P543, Array [-04]
	Actual value 5	—	—	P543, Array [-05]

Setpoints and actual values are transmitted by three different methods:

Percentage transmission

The process value is transmitted as an integer with a value range of -32768 to 32767 (8000 hex to 7FFF hex). The value "16384" (4000 hex) corresponds to 100%. The value "-16384" (C000 hex) corresponds to -100%.

For frequencies, the 100% value corresponds to parameter **P105 Maximum frequency** of the frequency inverter. For current, the 100% value corresponds to parameter **P112 Torque current limit** of the frequency inverter.

Frequencies and currents result from the following formulae:

$$Frequency = \frac{Value^* \times P105}{16384} \quad Current = \frac{Value^* \times P112}{16384}$$

* 16 Bit- setpoint or actual value which is transferred via the bus.

Binary transmission

Inputs and outputs as well as digital input bits and bus output bits are evaluated bit-wise.

Transmission of positions (SK 1x0E, SK 2xxE and SK 530E and above)

In the frequency inverter, positions have a value range of -50000.00...50000.00 rotations. A rotation of the motor can be subdivided into a maximum of 1000 increments. The subdivision depends on the encoder which is used.

The 32 Bit value range is divided into a "Low" and a "High" word, so that two setpoints or actual values are required for the transmission.

Direction of transmission	Transmitted data					
	SK 1x0E, SK 2xxE, SK 5xxE frequency inverters				Only frequency inverters SK 540E...SK 545E	
	1st word	2nd word	3rd word	4th word	5th word	6th word
To bus interface	Control word	32 Bit setpoint		Setpoint 3	Setpoint 4	Setpoint 5
From bus interface	Status word	Actual value 1	32 Bit actual value		Actual value 4	Actual value 5

Only the "Low" word for the position can also be transferred. This results in a limited value range from 32,767 to -32,768 rotations. This value range can be extended with the ratio factor (**Parameter P607 speed ratio** and **P608 Reduction**), however this reduces the resolution accordingly.

6.3.5 Process data telegrams

The process data telegram for a frequency inverter contains 8 or 12 bytes of frequency inverter data:

Direction of transmission	Transmitted data					
	SK 1x0E, SK 2xxE and SK 5xxE frequency inverters				Only SK 540E...SK 545E frequency inverters	
	1st word	2nd word	3rd word	4th word	5th word	6th word
	8 Byte					
	12 Byte					
To bus interface	Control word	Setpoint 1	Setpoint 2	Setpoint 3	Setpoint 4	Setpoint 5
From bus interface	Status word	Actual value 1	Actual value 2	Actual value 3	Actual value 4	Actual value 5

The process data telegram for a bus interface contains 2 Bytes, of which only the "Low" byte is used:

Direction of transmission	Transmitted data (2 Byte)								
	Low byte								High byte
	Bit 0	Bit 1	Bit 2	Bit 3	Bit 4	Bit 5	Bit 6	Bit 7	Bit 8...Bit 15
To bus interface	DO1	DO2	—	—	—	—	—	—	Not used
From bus interface	DIN1	DIN2	DIN3	DIN4	DIN5	DIN6	DIN7	DIN8	Not used

6.4 Parameter data transmission

In the "CAN over EtherCAT" protocol (CoE) transfer of parameter data is only carried out via a single SDO channel. The following are transferred

- Higher level parameter data for the bus module (1 bus interface with up to 4 connected frequency inverters),
- Parameter data which is queried by the bus master, either from the bus interface or from a frequency inverter (FI).

As the NORD parameter numbers of the bus interface and the frequency inverter (0 to 999) are within a number range of the EtherCAT field bus system which is already occupied, Getriebebau NORD GmbH & Co. has defined the following parameter number range:

	Bus interface	FI 1	FI 2	FI 3	FI 4
Start Offset	2000h				
Device Offset	0	800h	1000h	1800h	2000h
Numerical range	2000h-27FFh	2800h-2FFFh	3000h-37FFh	3800h-3FFFh	4000h-47FFh

NORD- parameter numbers must be converted according to the following formula:

Start offset + Device offset + NORD parameter number = EtherCAT parameter number

- **Example for parameter no. 102** ($P102 \rightarrow 102_{\text{dec}} = 66\text{h}$),
Frequency inverter FI2: $2000\text{h} + 1000\text{h} + 66\text{h} = 3066\text{h}$

i Information

Parameters with sub-index

For parameters with a sub-index, the first value is always on sub-index "1". Sub-index "0" contains the maximum size of the array.

6.4.1 EtherCAT parameters (CoE directory)

Index	Sub-index	Object name	Description	Read/Write	Type (value)
1000h	0	Device type	Device type and functionality	RO	U32
1008h	0	Device name	Device name	RO	STR
1009h	0	Hardware version	Hardware configuration level	RO	STR
100Ah	0	Software Version	Software version	RO	STR
1018h	REC	Identity object	General device information	—	U32
	0	Largest sub-index	Number of elements (=4)	RO	U8
	1	Vendor ID	Manufacturer code (Getriebbau Nord: 00000538h)	RO	U32
	2	Product code	Device version (product number)	RO	U32
	3	Revision number	Software version and revision number (2 x 16 Bit)	RO	U32
	4	Serial number	Not supported	RO	U32
1601h...1604h*	0	Largest sub-index	Number of elements	RO	U8
1600h	0-1	RxPDO Mapping	Process data for the outputs of the bus interface	RO	U32
1601h...1604h*	0-4	RxPDO Mapping	Setpoints for FI 1 to FI 4	RO	U32
1A00h...1A04h*	0	Largest sub-index	Number of elements	RO	U8
1A00h	0-1	TxPDO Mapping	Process data for the inputs of the bus interface	RO	U32
1A01h...1A04h*	0-4	TxPDO Mapping	Actual values for FI 1 to FI 4	RO	U32
1C00h	0-4	Sync.Manager Com. Type	Shows the assignment and use of Sync channels	RO	U8
1C10h	0	Sync.Manager Channel 0	Mailbox received	RO	UCHAR
1C11h	0	Sync.Manager Channel 1	Send mailbox	RO	UCHAR
1C12h	5	Sync.Manager Process Data Output	Process data output	RO	U16
1C13h	5	Sync.Manager Process Data Input	Process data input	RO	U16

* xx01 = FI 1, xx02 = FI 2, xx03 = FI 3, xx04 = FI 4

6.4.2 SDO error codes

If an SDO transmission fails, a corresponding error code is produced:

Error code	Description
05030000h	Toggle bit unchanged
05040000h	Timeout SDO message (timeout for the SDO response of the bus interface)
05040001h	SDO command invalid/unknown
05040005h	No memory (Insufficient memory)
06010000h	Illegal access to an object
06010001h	Reading access to write-only parameter
06020002h	Writing access to read-only object
06020000h	Object does not exist in the object dictionary (access to a non-existent parameter)
06040043h	Parameter incompatibility
06060047h	Internal incompatibility in the bus interface
06060000h	Access failed due to hardware error
06070012h	Incorrect data type, parameter too long
06070013h	Incorrect data type, parameter too short
06090011h	Sub-Index of parameter does not exist
06090030h	Parameter value range overflow
06090031h	Parameter value too large
06090032h	Parameter value too small
06090036h	Maximum value smaller than the minimum value
08000000h	General error
08000020h	Data transfer or saving not possible, as there is no communication between the bus interface and the frequency inverter

6.5 Example of setpoint specification

The following example shows the specification of a setpoint for switching a frequency inverter on and off. The frequency inverter is operated with a setpoint (setpoint frequency) and responds with an actual value (actual frequency). The maximum frequency is set to 50 Hz.

Parameter settings on the frequency inverter:

Parameter No.	Parameter name	Setting value
P105	Maximum frequency	50 Hz
P543	Actual bus value 1	1 (= Actual frequency)
P546	Function bus setpoint 1	1 (= Setpoint frequency)

Example



Order to FI		Response from the FI		Remarks
Control word	Setpoint 1	Status word	Actual value 1	
—	—	0000h	0000h	
—	—	xx40h	0000h	The mains voltage is switched on at the frequency inverter
047Eh	0000h	xx31h	0000h	The frequency inverter switches to "Ready for switch-on" status
047Fh	2000h	xx37h	2000h	The frequency inverter is set to "Operation enabled" status and controlled with a 50 % setpoint.
The frequency inverter is enabled, the motor is supplied with current and rotates with a frequency of 25 Hz.				
0047Eh	2000h	xx31h	0000h	The frequency inverter switches to "Ready for switch-on" status The motor brakes to a standstill according to the parameterised ramp and is disconnected from the power supply.
The frequency inverter is blocked again and the motor is without current.				
047Fh	1000h	xx37h	1000h	The frequency inverter is set to "Operation enabled" status and controlled with a 25% setpoint.
The frequency inverter is enabled, the motor is supplied with current and rotates with a frequency of 12.5 Hz.				

7 Parameters

The bus interface and frequency inverter parameters are communicated as words (16 Bit/Word). Exceptions to this are position values (POSICON), which are communicated as double words (32 Bit).

For field bus operation, several parameters must be set on the bus interface and the frequency inverter.

The parameters can be set with

- An external control or ParameterBox ( Manual [BU 0040](#)),
- NORD CON software ( Manual [BU 0000](#)) or
- The operator's PLC project.

7.1 Parameter setting on the bus interface

The parameters of the bus interface are divided into NORD-specific standard parameters and field-bus specific information parameters:

Parameter No.	Description
P15x	NORD standard parameter (can be set and saved)
P16x	EtherCAT standard parameter (can be set and saved)
P17x	NORD information parameter (display)
P18x	EtherCAT information parameter (display)

* Not present in EtherCAT bus interfaces

No parameters need to be set at the SK TU3-ECT bus interface, since the settings are made via frequency inverter parameters.

The NORD standard parameters **P151** to **P154** must be set on the bus interfaces SK CU4-ECT and SK TU4-ECT.

A detailed description of the bus interface parameters can be found in the following sections.

7.1.1 NORD standard parameters

The basic settings of the bus interface can be made via NORD standard parameters.

P150	Set relay			
Setting range	0...4			
Factory setting	{ 0 }			
Bus interface	SK TU4-ECT			
Description	The setting of this parameter determines the switching state of each digital output.			
Setting values	Value	Meaning	Comments	
	0	Via bus	All digital outputs are controlled via the PROFINET. The functions are defined in the frequency inverter (P480).	
	1	Outputs Off	All digital outputs are set to "Low" (0 V)	
	2	Output 1 On (DO1)	Digital output DO1 is set to "High" (active), digital output DO2 is set to "Low" (0 V).	
	3	Output 2 On (DO2)	Digital output DO2 is set to "High" (active), digital output DO1 is set to "Low" (0 V).	
	4	Outputs 1 and 2 ON	All digital outputs are set to "High" (active)	
P151	Timeout for external bus			
Setting range	0...32767 ms			
Factory setting	{ 0 }			
Bus interface	SK CU4-ECT, SK TU4-ECT			
Description	Monitoring function of the bus interface After receipt of a valid telegram, the next telegram must arrive within the set time. Otherwise the bus interface or the connected frequency inverter reports an error (E010/10.3 "Time Out") and switches off. See also parameter P513 Telegram timeout time for the frequency inverter.			
Setting values	0 = Monitoring Off			
P152	Factory setting			
Setting range	0...1			
Factory setting	{ 0 }			
Bus interface	SK CU4-ECT, SK TU4-ECT			
Description	Reset the present parameter settings of the bus interface to the factory setting.			
Setting values	Value	Meaning	Remarks	
	0	No change	Current parameter settings will not be changed	
	1	Load factory setting	All bus interface parameters will be reset to the factory setting. The setting of parameter P152 then automatically changes back to { 0 }.	
	2	Basic parameters	All basic parameters of the bus interface will be reset to the factory setting. The setting of parameter P152 then automatically changes back to { 0 }.	
	3	i-Parameters	The individual safety parameters (P800 ... P830) of the bus interface will be reset to the factory setting. The setting of parameter P152 then automatically changes back to { 0 }.	

P153	Min. system bus cycle		
Setting range	0...250 ms		
Arrays	[-01] = TxSDO Inhibit Time [-02] = TxPDO Inhibit Time		
Factory setting	{ [-01] = 10 } { [-02] = 5 }		
Bus interface	SK CU4-ECT, SK TU4-ECT		
Description	Set the pause time for the system bus in order to reduce the bus load.		
P154	TB-IO access		
Setting range	0...5		
Arrays	[-01] = Access to inputs [-02] = Access to outputs		
Factory setting	{ [-01] = 0 } { [-02] = 0 }		
Bus interface	SK CU4-ECT, SK TU4-ECT		
Description	Assign reading and writing rights of each connected frequency inverter to 2 inputs and 2 outputs of the bus interface. This is carried out via the following frequency inverter parameters:		
	Input 1	Evaluation via P480 Funct. BusIO In Bits , Array [-11]	
	Input 2	Evaluation via P480 Funct. BusIO In Bits , Array [-12]	
	Output 1	Evaluation via P481 Funct. BusIO Out Bits , Array [-09]	
	Output 2	Evaluation via P481 Funct. BusIO Out Bits , Array [-10]	
Setting values	Value	Meaning	Comments
	0	No access	No influence by the frequency inverter.
	1	Broadcast (inputs)	All connected frequency inverters read the inputs (Array [-02] = No function).
	2	FI 1	Frequency inverter 1 reads and writes to the inputs and outputs.
	3	FI 2	Frequency inverter 2 reads and writes to the inputs and outputs.
	4	FI 3	Frequency inverter 3 reads and writes to the inputs and outputs.
	5	FI 4	Frequency inverter 4 reads and writes to the inputs and outputs.

7.1.2 EtherCAT standard parameters

Field-bus specific settings of the bus interface are made via the EtherCAT standard parameters.

P160	Second Address
Setting range	0...4096
Factory setting	{ 0 }
Bus interface	SK CU4-ECT, SK TU4-ECT
Description	Setting of the "Second Address" for the Hot Connect function.
Note	This parameter is available for firmware version V1.8 R0 and above. The setting of this parameter is only adopted if the corresponding DIP switch is in the position "0" (the DIP switch setting has priority). The address which is set is only adopted by the bus interface after a "POWER ON". The IP address which is set can be determined via the parameter P181 .

7.1.3 NORD information parameters

NORD information parameters are used to display current and archived error messages, as well as current operating states.

P170	Actual error
Display range	0...9999
Arrays	[-01] = Actual error in bus interface [-02] = Last error in bus interface
Bus interface	SK TU3-ECT, SK CU4-ECT, SK TU4-ECT
Description	Display of the actual error present. For a list of possible error messages please refer to  Section 8 "Error monitoring and error messages".
Note	The error message is reset when the supply voltage is switched off.
P171	Software version
Display range	0.0...9999.9
Arrays	[-01] = Software version [-02] = Software revision [-03] = Special version
Bus interface	SK TU3-ECT, SK CU4-ECT, SK TU4-ECT
Description	Display of the software version and revision number of the bus interface. Array [-03] shows possible special versions (0 = standard version).

P172	Configuration level
Display range	0...
Bus interface	SK TU3-ECT, SK CU4-ECT, SK TU4-ECT
Description	Display of the bus interface identifier.

Display values	Value	Meaning
	0	CU4 (internal)
1	TU4 (external)	Bus interfaceSK TU4-ECT
2	TU3 (Techn. Unit)	Bus interfaceSK TU3-ECT,
3	TU3 (Techn. Unit)+DIP	Bus interface SK TU3-ECT, with DIP switch

P173	Module status
Display range	0...FFFFh
Bus interface	SK TU3-ECT, SK CU4-ECT, SK TU4-ECT
Description	Displays the operating state of the bus interface.

Display values	Bit	Meaning															
	0	Initialisation (Bus status "PREOPERATIONAL")															
1	Bus status "SAFE OPERATIONAL" or "OPERATIONAL"																
2	Timeout (EtherCAT)																
3	Timeout (time set in parameters P151)*																
4	No communication with ASIC																
5	General configuration error																
6	System bus "Bus WARNING"																
7	System bus "Bus OFF"																
8	FI1 status	Status for frequency inverter Bit 8...Bit 15: <table border="1" data-bbox="673 1249 1342 1406"> <thead> <tr> <th>Bit "High"</th> <th>Bit "Low"</th> <th>Meaning</th> </tr> </thead> <tbody> <tr> <td>0</td> <td>0</td> <td>Frequency inverter "offline"</td> </tr> <tr> <td>0</td> <td>1</td> <td>Unknown frequency inverter</td> </tr> <tr> <td>1</td> <td>0</td> <td>Frequency inverter "online"</td> </tr> <tr> <td>1</td> <td>1</td> <td>Frequency inverter lost or switched off</td> </tr> </tbody> </table>	Bit "High"	Bit "Low"	Meaning	0	0	Frequency inverter "offline"	0	1	Unknown frequency inverter	1	0	Frequency inverter "online"	1	1	Frequency inverter lost or switched off
Bit "High"	Bit "Low"		Meaning														
0	0		Frequency inverter "offline"														
0	1		Unknown frequency inverter														
1	0		Frequency inverter "online"														
1	1		Frequency inverter lost or switched off														
9																	
10	FI 2 status																
11																	
12	FI 3 status																
13																	
14	FI 4 status																
15																	

* Not for bus interface SK TU3-ECT

P174	Digital input status			
Display range	0...255 (00000000...11111111b)			
Bus interface	SK CU4-ECT, SK TU4-ECT			
Description	Display of the actual switching status of the digital bus interface inputs.			
Display values	Bit	Meaning		
	0	Input 1 (DIN1) of the bus interface		
	1	Input 2 (DIN2) of the bus interface		
	2	Input 3 (DIN3) of the bus interface ¹		
	3	Input 4 (DIN4) of the bus interface ¹		
	4	Input 5 (DIN5) of the bus interface ¹		
	5	Input 6 (DIN6) of the bus interface ¹		
	6	Input 7 (DIN7) of the bus interface ¹		
7	Input 8 (DIN8) of the bus interface ¹			

¹ Only bus interface , SK TU4-ECT

P175	Relay status			
Display range	0...3 (00...11b)			
Bus interface	SK TU4-ECT			
Description	Display of the actual switching status of the relay outputs of the bus interface.			
Display values	Bit	Meaning		
	0	Output 1 (DO1) of the bus interface		
	1	Output 2 (DO2) of the bus interface		

P176	Process data Bus In			
Display range	-32768...32767			
Arrays	[-01] =	Bus module outputs ¹		
	[-02] =	Control word	[-03]...[-07] =	Setpoint 1...5 to F11
	[-08] =	Control word	[-09]...[-13] =	Setpoint 1...5 to F12
	[-14] =	Control word	[-15]...[-19] =	Setpoint 1...5 to F13
	[-20] =	Control word	[-21]...[-25] =	Setpoint 1...5 to F14
	¹ Only bus interface SK CU4-ECT, SK TU4-ECT			
Bus interface	SK TU3-ECT, SK CU4-ECT, SK TU4-ECT			
Description	Display of data received from the EtherCAT-Busmaster.			
Note	Setpoints 4 and 5 are only possible with SK 54xE frequency inverters.			

P177	Process data Bus Out				
Display range	-32768...32767				
Arrays	[-01] =	Bus module inputs ¹			
	[-02] =	Status word	[-03]...[-07] =	Actual value 1...5	from FI1
	[-08] =	Status word	[-09]...[-13] =	Actual value 1...5	from FI2
	[-14] =	Status word	[-15]...[-19] =	Actual value 1...5	from FI3
	[-20] =	Status word	[-21]...[-25] =	Actual value 1...5	from FI4
	¹ Only bus interface SK CU4-ECT, SK TU4-ECT				
Bus interface	SK TU3-ECT, SK CU4-ECT, SK TU4-ECT				
Description	Display of the data sent from the bus interface to the EtherCAT-Busmaster.				
Note	Actual values 4 and 5 are only possible with SK 54xE frequency inverters.				
P178	Internal temperature				
Display range	-128 ... 127 C				
Bus interface	SK CU4-ECT,				
Description	Display of the temperature inside the housing of the bus interface.				
Note	If the temperature in the housing exceeds 91 °C for more than one minute, an error is set.				

7.1.4 EtherCAT information parameters

EtherCAT information parameters are used to display statuses and settings which are specific to the field bus.

P180	NMT State		
Display range	0...8		
Bus interface	SK TU3-ECT, SK CU4-ECT, SK TU4-ECT		
Description	Display of the communication status (startup phase) of the bus interface.		
Note	Switch-over between the communication states is carried out by the operator's PLC (EtherCAT-Busmaster).		
Display values	Value	Meaning	
	1	INIT	Initialisation phase (no communication)
	2	PREOPERATIONAL	Only parameter communication
	4	SAFEOPERATIONAL	Restricted communication (Setpoints are not evaluated)
	8	OPERATIONAL	Unrestricted communication
P181	Second Address		
Display range	-1...4095		
Bus interface	SK TU3-ECT, SK CU4-ECT, SK TU4-ECT		
Description	Displays the address which is set for the Hot Connect function		
Note	"0" = No address set.		
P182	EtherCAT Watchdog		
Display range	1...65535 ms		
Bus interface	SK TU3-ECT, SK CU4-ECT, SK TU4-ECT		
Description	Display of the watchdog monitoring time in ms		
Note	"0" = Watchdog not active		
P183	EtherCAT error		
Display range	0...FFh		
Bus interface	SK TU3-ECT, SK CU4-ECT, SK TU4-ECT		
Arrays	[-01] = 300h: Error on the Rx port	[-03] = 310h: Lost Link on the Rx port	
	[-02] = 302h: Error on the Tx port	[-04] = 311h: Lost Link on the Tx port	
Description	Display of the errors which have occurred at the EtherCAT level.		
P184	SPI error counter		
Display range	0...FFFFh		
Bus interface	SK CU4-ECT, SK TU4-ECT		
Description	Counter display for communication errors between ASIC and the bus interface processor.		

7.2 Parameter settings on the frequency inverter

After connection and addressing of the bus interface, the additional parameters of the frequency inverter must be set as listed below. The additional parameters of the frequency inverter are used to set the bus interface, the pulse frequency and acknowledgement of errors.

A detailed description of the parameters can be found in the relevant manual for the frequency inverter.

Additional parameters

The following table contains a list of additional parameters which are relevant for the bus interface.

No.	Parameter name	Recommended setting			Comments
		SK CU4/SK TU4	SK TU3		
		SK 1x0E, SK 2xxE	SK 500E–SK 535E	SK 54xE	
P509	Source Control Word	"3" = System bus	"8" = Ethernet TU	"8" = Ethernet TU	SK 511E frequency inverters and above: Communication with the bus interface via the system bus is possible with setting "6" = CANopen.
P510	Setpoint source	"0" = Auto	"0" = Auto	"0" = Auto	If P509 is set to "3", "6" or "8"
P513	Telegram timeout	—	○ ¹	○ ¹	
P514	CAN bus baud rate	"5" = 250 kBaud	"5" = 250 kBaud	"5" = 250 kBaud	
P515	CAN address (Array [-01])	32, 34, 36 or 38	32, 34, 36 oder 38*	32, 34, 36 oder 38*	System bus address
P543	Actual bus value Arrays [-01]...[-03]	○ ²	○ ²	○ ²	Refer to the relevant frequency inverter operating manual
	Actual bus value Arrays [-04]...[-05]	—	—	○ ²	
P543	Actual bus value 1	—	○ ²	—	
P544	Actual bus value 2	—	○ ²	—	
P545	Actual bus value 3	—	○ ²	—	
P546	Function Bus setpoint Arrays [-01]...[-03]	○ ²	—	○ ²	Refer to the relevant frequency inverter operating manual
	Function Bus setpoint Arrays [-04]...[-05]	—	—	○ ²	
P546	Function Bus setpoint 1	—	○ ²	—	
P547	Function Bus setpoint 2	—	○ ²	—	
P548	Function Bus setpoint 3	—	○ ²	—	

* Only necessary if more than one frequency inverter is connected to bus interface SK TU3-ECT.,

○¹ Depending on the application: Change the settings according to the requirements of the application.

○² Depending on the function: Setting according to the required function(s) is necessary.

Information parameters

Information parameters are used to display current and archived error messages, as well as current operating states and settings.

The following table contains a list of information parameters which are relevant for the bus interface.

No.	Parameter name	SK TU3	SK CU4	SK TU4																																																	
P700	Current error	Array [-01]																																																			
	Current warning	Array [-02]																																																			
	Reason for switch-on block	Array [-03]																																																			
P701	Last fault																																																				
P740	Process data Bus In	No display if P509 is set to "0"																																																			
P741	Process data Bus Out																																																				
P744	Configuration																																																				
P745	Module version		—																																																		
P746	Module status*	<p>Possible values:</p> <table border="1"> <thead> <tr> <th>Bit</th> <th>Meaning</th> </tr> </thead> <tbody> <tr> <td>0</td> <td>EtherCAT status PREOPERATIONAL</td> </tr> <tr> <td>1</td> <td>EtherCAT status SAFEOPERATIONAL or OPERATIONAL</td> </tr> <tr> <td>2</td> <td>Vacant</td> </tr> <tr> <td>3</td> <td>Vacant</td> </tr> <tr> <td>4</td> <td>Error 1</td> </tr> <tr> <td>5</td> <td>Error 2</td> </tr> <tr> <td>6</td> <td>Error 3</td> </tr> <tr> <td>7</td> <td>Vacant</td> </tr> <tr> <td>8...15</td> <td>Bus interface number</td> </tr> </tbody> </table> <p>Table of errors:</p> <table border="1"> <thead> <tr> <th colspan="3">Error</th> <th>Meaning</th> </tr> <tr> <th>3</th> <th>2</th> <th>1</th> <th></th> </tr> </thead> <tbody> <tr> <td>0</td> <td>0</td> <td>0</td> <td>No error</td> </tr> <tr> <td>0</td> <td>0</td> <td>1</td> <td>No communication with EtherCAT ASIC</td> </tr> <tr> <td>0</td> <td>1</td> <td>0</td> <td>EtherCAT watchdog timeout</td> </tr> <tr> <td>0</td> <td>1</td> <td>1</td> <td>P513 timeout</td> </tr> <tr> <td>1</td> <td>0</td> <td>0</td> <td>General EtherCAT configuration error</td> </tr> </tbody> </table>		Bit	Meaning	0	EtherCAT status PREOPERATIONAL	1	EtherCAT status SAFEOPERATIONAL or OPERATIONAL	2	Vacant	3	Vacant	4	Error 1	5	Error 2	6	Error 3	7	Vacant	8...15	Bus interface number	Error			Meaning	3	2	1		0	0	0	No error	0	0	1	No communication with EtherCAT ASIC	0	1	0	EtherCAT watchdog timeout	0	1	1	P513 timeout	1	0	0	General EtherCAT configuration error	—	
Bit	Meaning																																																				
0	EtherCAT status PREOPERATIONAL																																																				
1	EtherCAT status SAFEOPERATIONAL or OPERATIONAL																																																				
2	Vacant																																																				
3	Vacant																																																				
4	Error 1																																																				
5	Error 2																																																				
6	Error 3																																																				
7	Vacant																																																				
8...15	Bus interface number																																																				
Error			Meaning																																																		
3	2	1																																																			
0	0	0	No error																																																		
0	0	1	No communication with EtherCAT ASIC																																																		
0	1	0	EtherCAT watchdog timeout																																																		
0	1	1	P513 timeout																																																		
1	0	0	General EtherCAT configuration error																																																		
P748	CANopen status	Displays the system bus status																																																			

8 Error monitoring and error messages

Bus interfaces and frequency inverters are equipped with monitoring functions and generate error messages in case of deviations from the normal operating state.

8.1 Bus operation monitoring function

Independent of the specific bus watchdogs, comprehensive monitoring functions are integrated into Getriebbau NORD GmbH & Co. KG frequency inverters and bus interfaces. With the aid of this "Timeout" monitoring, communication problems are detected, which are either related to general functionalities ("No bus communication") or are related to special modules ("Failure of a participant").

Monitoring of communication at the field bus level is primarily carried out via the bus interface. Field bus communication faults are registered in the bus interface. If an error at field bus level causes an error in the frequency inverter, the frequency inverter also displays a corresponding error. The frequency inverter itself does not monitor communication on the field bus level.

Monitoring of communication on the NORD system bus level (between the frequency inverter and the bus interface) is carried out by the frequency inverter. An error in the system bus communication is registered in both the bus interface and the frequency inverter and results in specific error messages.

Function	Parameter						
	Bus interface	SK CU4 and SK TU4 via NORD system bus			SK TU3 ¹⁾	SK TU3 via CANopen/NORD system bus ²⁾	
		Frequency inverters	SK 1x0E SK 2xxE	SK 511E ... SK 535E	SK 54xE ³⁾	SK 5xxE	SK 511E ... SK 535E
Field bus timeout		P151	P151	P151	P513	P513	P513
Optional monitoring (system bus timeout)		P120	P513	P120	— ⁴⁾	P513	P120
Bus interface error display		P170 (P700)	P170 (P700)	P170 (P700)	P170 ²⁾ P700	P170 P700	P170 P700
Error display for frequency inverter and communication errors between the frequency inverter and the bus interface.		P700	P700	P700	P700	P700	P700

1) Only for communication between the SK TU3 bus interface and the frequency inverter on which the bus interface is mounted.

2) Only for Ethernet-based bus interfaces

3) Connection for CANopen (Parameter **P509**)

4) Monitoring is automatic and cannot be set.

Information

Parameter **P513**

The setting ("0.1" = No error) of parameter **P513 Telegram timeout time** ensures that the frequency inverter ignores all communication errors on both the field bus and the system bus level. The frequency inverter maintains its operating status.

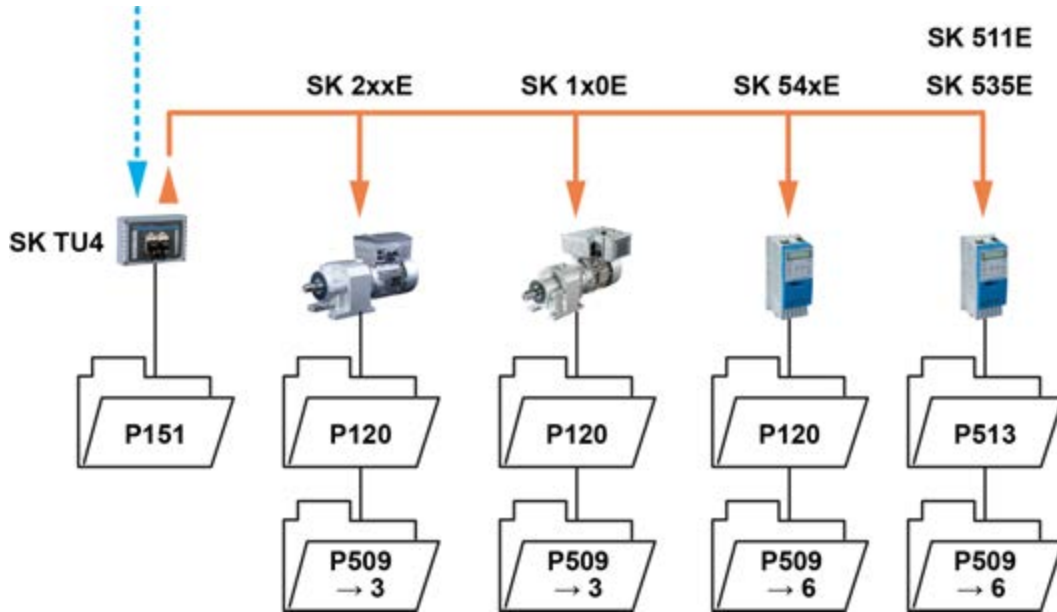

Figure 8: Examples of monitoring parameter settings – SK TU4 bus interface

Setting values for parameter **P509 Control word source**:

3 = System bus

6 = CANopen

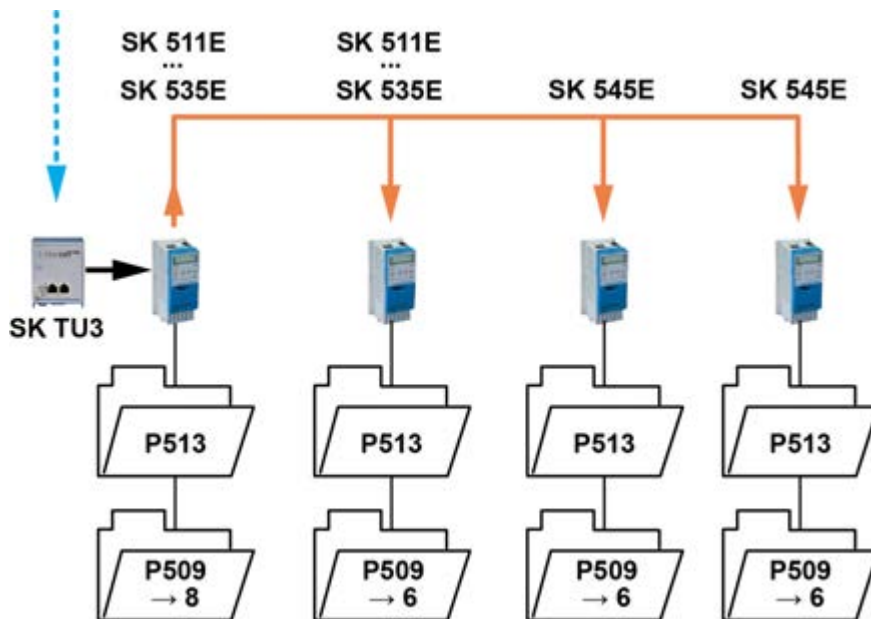

Figure 9: Examples of monitoring parameter settings – SK TU3 bus interface

Setting values for parameter **P509 Control word source**:

8 = Ethernet TU

6 = CANopen

8.2 Resetting error messages

There are several methods for resetting (acknowledging) an error message.

On the frequency inverter:

- Switch the mains voltage off and on again, or
- Actuate the programmed digital input with parameter **P420 Digital inputs** (Setting 12 = Acknowledge error), or
- Switch off "Enable" on the frequency inverter (if no digital input is parameterised to the function "Acknowledge errors"), or
- By carrying out a bus acknowledgement, or
- Automatic error acknowledgement by activating parameter **P506 Auto. error acknowledgement**.

On the bus interface

The error message (via information parameter **P170**, [-01]) is automatically reset if the error is no longer active. Otherwise:

- Switch the voltage supply to the bus interface off and on again, or
- Acknowledge the error via the field bus.

Information

Archiving error messages

An error message (display via parameter **P170**) is only displayed as long as it is active. After the error has been remedied, the message is deleted and is archived as the last error message in parameter **P170**, Array [-02]. If the mains supply is interrupted before the error is remedied, the message is lost, i.e. it is not archived.

Information

Error display in the SimpleBox

An error message is displayed in the operating display of the SimpleBox SK CSX-3H by display of the error group number "E1000". The bus interface parameter **P170**, Array [-01] must be selected to determine the actual error.

8.3 Handling of errors in the bus interface

If errors occur in frequency inverters which are connected to the NORD system bus, the bus interface sends an error message to the EtherCAT bus master via "Emergency Message" (CANopen over EtherCAT). This message has the following structure:

Byte 0	Byte 1	Byte 2	Byte 3	Byte 4	Byte 5	Byte 6	Byte 7
Error code		Error index	FI ID 0...3	Not used			

"FI ID" identifies the frequency inverter in which the error occurred.

8.3.1 Error Groups

The error groups listed below have been defined in the CANopen communication profile DS 301, which is also used for EtherCAT bus interfaces.

Error code	Meaning
00xxh	No error
10xxh	Undefined error type
20xxh	Current error
30xxh	Voltage error
40xxh	Temperature error
50xxh	Hardware error
60xxh	Software error
70xxh	Additional module
80xxh	Communication
90xxh	External error
FF00h	Specific to device

8.3.2 Status word from the frequency inverter.

Error messages which are generated by the frequency inverter are transferred from the bus interface to the field bus level. They do not result in an error of the bus interface.

Allocation of frequency inverter error codes:

Error code	Error index	Frequency inverter (P700)*	
		Error code	Meaning
1000h	0	0	No error
1000h	1	—	The error number which has been sent from the frequency inverter is unknown to the bus interface and must be read out via parameter P700 or an actual value.
2200h	3	4.0/4.1	Overcurrent frequency inverter/current measurement
2310h	3	3.0	Overcurrent I ² t-limit
2311h	3	3.2	IGBT overcurrent 125 %
2312h	3	3.3	IGBT overcurrent 150 %
3110h	5	5.1	Mains voltage too high
3120h	5	6.1	Mains voltage too low
3130h	5	7.0	Mains connection failure
3210h	5	5.0	Link circuit voltage too high
3230h	5	6.0	Link circuit voltage too low
4210h	9	1.1	Overtemperature in frequency inverter
4310h	9	2.0/2.1/2.2	Motor overtemperature
5000h	1	10.1	Bus interface communication error
5110h	1	11.0	External bus error
5300h	1	17.0	EMC fault
5510h	1	20.0	Reserved
5520h	1	20.8	EEPROM error
5530h	1	8.2	External copy error
6000h	1	20.1...20.7/21.3	System error
7112h	3	3.1	Brake chopper overcurrent
7120h	1	16.0/16.1	Motor error
7305h	1	13.0	Encoder error
8100h	17	10.0...10.2	Bus timeout
8111h	17	10.3...10.7/10.9	Bus interface communication error
8300h	1	13.2	Slip error switch-off monitoring
8400h	1	13.1	Speed slip error
9000h	1	12.0	External watchdog
FF00h	129	18.0	Reserved
FF10h	129	19.0	Motor identification failed

* For a detailed description of the error code  frequency inverter manual.

8.4 Error messages

Error messages from the bus interface can be read out via parameter **P170** of the bus interface (Array [-01] = Actual error, Array [-02] = Previous error).

Error	Meaning	Comments
100.0	EEPROM error	EMC fault, bus interface defective
102.0	Bus timeout P151	By means of timeout supervision parameter P151/P513
103.0	System bus Off	No 24 V voltage on bus, connections not correct
104.0	Overtemp. Module	Only SK CU4-ECT bus interface
540.0	EtherCAT ASIC Error	No communication with ASIC
540.1	EtherCAT Bus Overflow	Configuration problem by the bus master.
540.2		
542.0	EtherCAT timeout	Connection timeout
564.0	MAC address error	MAC address defective

Error messages which occur in relation to the bus interface are depicted as follows in the error memory of the frequency inverter (Parameter **P700** and **P701**).

Error (E010)	Meaning	Comments
10.1	ASIC error	<ul style="list-style-type: none"> EtherCAT-ASIC no longer responding. <ul style="list-style-type: none"> Reset the error by switching the 24 V supply to the bus interface off and on again. <i>Only SK CU4-ECT bus interface</i> <ul style="list-style-type: none"> Excess temperature >97 °C.
10.2	Timeout EtherCAT Watchdog	<ul style="list-style-type: none"> Bus master timeout has triggered Telegram transfer error. <ul style="list-style-type: none"> Check the connections and links and the program sequence in the Bus Master.
10.3	Timeout by P151/P513	<ul style="list-style-type: none"> System bus monitoring has triggered <ul style="list-style-type: none"> Check time setting of parameter P151/P513. The enable bit is missing in the control word.
10.5	General EtherCAT configuration error	<ul style="list-style-type: none"> Configuration error by the bus master.
10.8	TU3 system bus error	<i>Only SK TU3-ECT bus interface:</i> <ul style="list-style-type: none"> Connection between bus interface and frequency inverter interrupted.
10.9	TU4 system bus error	<i>Only bus interfaces SK CU4-ECT and SK TU4-ECT:</i> <ul style="list-style-type: none"> Connection between bus interface and frequency inverter interrupted (see setting of parameter P120).

9 Appendix

9.1 Repair information

In order to keep repair times as short as possible, please state the reasons for the return of the device and at least one contact partner in case of queries.

In case of repairs, please send the device to the following address:

NORD Electronic DRIVESYSTEMS GmbH

Tjüchkampstraße 37
26606 Aurich, Germany

i Information

Third party accessories

Before returning a bus interface and/or a frequency inverter, please remove any external accessories such as mains cables, potentiometers, external displays, etc., which were not supplied by Getriebebau NORD GmbH & Co. KG. No liability can be accepted by Getriebebau NORD GmbH & Co. KG for devices which are returned with third party accessories.

i Information

Accompanying document

Please use the filled-in accompanying document for returns. You can find this on our homepage www.nord.com or directly under the link [Warenbegleitschein](#).

For queries about repairs, please contact:

Getriebebau NORD GmbH & Co. KG

Tel.: +49 (0) 45 32 / 289-2515

Fax: +49 (0) 45 32 / 289-2555

9.2 Service and commissioning information

In case of problems, e.g. during commissioning, please contact our Service department:

☎ +49 4532 289-2125

Our Service department is available 24/7 and can help you best if you have the following information about the device and its accessories to hand:

- Type designation,
- Serial number,
- Firmware version

9.3 Documents and software

Documents and software can be downloaded from our website www.nord.com.

Other applicable documents and further information

Documentation	Contents
TI 275271017	Technical Information/Data Sheet for bus interface SK CU4-ECT (for IP55 devices)
TI 275271517	Technical Information/Data Sheet for bus interface SK CU4-ECT-C (for IP66 devices)
TI 275281117	Technical Information/Data Sheet for bus interface SK TU4-ECT (for IP55 devices)
TI 275281167	Technical Information/Data Sheet for bus interface SK TU4-ECT-C (for IP66 devices)
TI 275900180	Technical Information/Data Sheet for bus interface SK TU3-ECT (for IP20 devices)
BU 0180	Manual for SK 1x0E frequency inverters
BU 0200	Manual for SK 2xxE frequency inverters
BU 0250	Manual for SK 2xxE-FDS frequency inverters
BU 0500	Manual for frequency inverters SK 500E to SK 535E
BU 0505	Manual for SK 54xE frequency inverters
BU 0000	Manual for use of NORD CON software
BU 0040	Manual for use of NORD parameterisation units

Software

Software	Description
XML file	Device description file for EtherCAT configuration software
NORD CON	Parametrisation and diagnostic software

Key word index

A		Bus interface	55
Accompanying document	56	Frequency inverters.....	55
Actual error (P170)	43	from the frequency inverter	53
Actual value		Reset	52
IW	26	Error monitoring	43, 50
Actual values	33	EtherCAT	
B		characteristics	12
Binary transmission	33	telegram	14
Bus address		EtherCAT error (P183).....	47
DIP switch	20	EtherCAT parameter	
Bus master		CoE directory.....	37
Integration	20, 21, 24, 26	EtherCAT watchdog (P182).....	47
Bus node.....	16	Extra functions	48
Bus protocol.....	14	F	
C		Factory settings (P152).....	41
CAN bus address (P515).....	16	Field bus address.....	14, 22
CAN bus baud rate (P514)	16	H	
CAN over EtherCAT		Hot-Connect function	14, 22
CoE	36	I	
CAN-ID	16	Information parameter.....	49
CANopen	15	Internal temperature (P178).....	46
Commissioning	20, 23	M	
Configuration level (P172).....	44	Min. system bus cycle (P153).....	42
Connection	20	Module status (P173).....	44
Control bit	27	Monitoring functions.....	50
Control word	27, 31	Monitoring parameter.....	51
STW	26	N	
D		NMT State (P180)	47
Data transmission.....	25	NMT status machine	26
Device characteristics.....	21	NORD CON computer	15
Device description file.....	21	NORD parameter numbers.....	36
Device detection	21	NORD system bus	8, 15
Documents		NORDCON software.....	18
other applicable.....	57	P	
E		Parameter	
Electrician	10	Bus interface	40
Error messages	43, 50	Frequency inverters.....	48

Parameter data.....	25	Setpoints	33
Parameter data transmission.....	21, 36	SimpleBox.....	17
Parameter settings		Software.....	57
Frequency inverters	48	Software version	
ParameterBox.....	17	P171	43
Percentage transfer	33	SPI error counter(P184).....	47
Process data.....	22, 25	Status bit	28
Process data Bus In (P176).....	45	Status machine	
Process data bus Out (P177).....	46	Frequency inverter	29
Process data telegram.....	35	Status of digital in. (P174).....	45
R		Status word	28, 32
Relay status (P175).....	45	ZSW.....	26
Remote maintenance	19	T	
Repair	56	TB-IO access (P154)	42
Returns	56	Telegram timeout (P513).....	50
S		Timeout	50
SDO error codes.....	38	Timeout for external bus (P151)	41
Second Address	22	Topology	
Second Address (P160)	43	Linear	13
Second Address (P181)	47	Tree	13
Set relay (P150).....	41	Transfer of process data	22, 25, 26
Setpoint		Transmission of positions	34
SW	26	U	
Setpoint specification		USS protocol.....	17
Example	39		

NORD DRIVESYSTEMS Group

Headquarters and Technology Centre
in Bargteheide, close to Hamburg

Innovative drive solutions
for more than 100 branches of industry

Mechanical products
parallel shaft, helical gear, bevel gear and worm gear units

Electrical products
IE2/IE3/IE4 motors

Electronic products
centralised and decentralised frequency inverters,
motor starters and field distribution systems

7 state-of-the-art production plants
for all drive components

Subsidiaries and sales partners
in 98 countries on 5 continents
provide local stocks, assembly, production,
technical support and customer service

More than 4,000 employees throughout the world
create customer oriented solutions

www.nord.com/locator

Headquarters:

Getriebebau NORD GmbH & Co. KG
Getriebebau-Nord-Straße 1
22941 Bargteheide, Germany
T: +49 (0) 4532 / 289-0
F: +49 (0) 4532 / 289-22 53
info@nord.com, www.nord.com

Member of the NORD DRIVESYSTEMS Group

