

GETRIEBEBAU NORD

Member of the NORD DRIVESYSTEMS Group



Getriebebau NORD GmbH & Co. KG

Getriebebau-Nord-Straße 1 • 22941 Bargteheide, Germany • www.nord.com

SK CU4-ETH

Part number: 275 271 027

Industrial Ethernet – Internal bus interface ¹⁾

- 1) With NORDAC *LINK*, Industrial Ethernet is factory-fitted as a purchased option and configured according to customer specifications. Retrofitting is not possible.

The bus interface may only be installed and commissioned by qualified electricians. An electrician is a person who, because of their technical training and experience, has sufficient knowledge with regard to

- Switching on, switching off, isolating, earthing and marking power circuits and devices,
- Proper maintenance and use of protective devices in accordance with defined safety standards.

DANGER

Danger of electric shock

The frequency inverter carries hazardous voltage for up to 5 minutes after being switched off.

- Work must not be carried out unless the frequency inverter has been disconnected from the voltage and at least 5 minutes has elapsed since the mains was switched off.

Validity of document

This document is only valid in conjunction with the operating instructions of the respective frequency inverter and the bus communication manual for this bus interface ( See overview at end of document). These documents contain all of the information that is required for safe commissioning of the bus interface module and the frequency inverter.

Scope of delivery

1 x	Bus interface	SK CU4-ETH
1 x	Cable set system bus	grey/black
1 x	Set of cables 24 VDC	brown/blue
2 x	Screws	M4 x 20, Phillips head



Field of use

Internal interface for connecting a decentralised frequency inverter (NORDAC *BASE*, NORDAC *FLEX*, NORDAC *LINK*) to the **Industrial Ethernet** (EtherCAT, PROFINET IO and EtherNet/IP). It is connected with the frequency inverter via the system bus and can directly control up to four frequency inverters. Two digital inputs are available.

Technical Information / Datasheet	SK CU4-ETH			
Industrial Ethernet Module	TI 275271027	V 1.1	3622	en

Technical data

Bus interface

Temperature range	-30 °C ... +40 °C *	Vibration resistance	2M4
Temperature class	Class 3k3	Supply voltage	24 V ± 20%, ≈ 100 mA Polarity protected
Protection class	IP20		

* The upper temperature limit depends on frequency inverter and operating mode → see "Derating"

Digital input - Operating range	Low: 0 V ... 5 V, High: 15 V ... 30 V
Digital input - Specific data	R _i = 10 kΩ, Input capacitance: 10 nF, Response time 1 ms, Inputs according to EN 61131-2 Type 1

Bus specification

EtherCAT	max. 100 Mbaud	Cable	min. Ethernet CAT-5
EtherNet/IP	electrical isolation 500 V _{eff}	max. cable length	100 m between two Ethernet participants
PROFINET IO		Shield	directly on PE
Bus connection	screw terminals	PE port	via PE screw terminal in connection box
Bus termination	carried out automatically		
Status display	6 LED		
Topology	star, tree, ring, line		

Power

Parameter read access to frequency inverter	≈ 12 ms
Parameter write access with saving in EEPROM	≈ 25 ms

Derating

NOTICE

Derating

Depending on the installation location of the bus interface, the operating mode (S1, S3 ...) and the assembly type (wall- or motor-mounted) of the frequency inverter as well as the used motor type (IE1/IE2/ ...), restrictions of the permissible ambient temperature must be considered. If the permissible ambient temperature is exceeded, the bus interface may heat up impermissibly and switch off with an error message (E220.3).

Operating mode	Assembly type	Maximum ambient temperature ¹⁾
S1	Motor-mounted on IE2 motor	+35 °C
S1	Motor-mounted on IE3 motor	+40 °C
S1	Motor-mounted on IE4 motor	+40 °C
S1	Motor-mounted on IE5+ motor	+40 °C
S1	Wall-mounted	+40 °C ²⁾

1) The limitations of the frequency inverters must not be exceeded (□ Frequency inverter manual).

2) NORDAC FLEX: Here, +45 °C is possible with ventilated wall mounting.

Features of the bus interface when using EtherCAT

Parameterisation	via CoE (CANopen over EtherCat)
Error messages (emergency messages)	according to CiA 301
Identification (Hot-Connect)	Configured Station Alias (via bus interface parameter) or Explicit Device Identification (via DIP switch or bus interface parameter)
Distributed Clocks	are not supported
Access for NORD diagnosis tool	via diagnostics socket on the frequency inverter
Firmware update	via File Access over EtherCAT (FoE) or NORDCON software

Features of the bus interface when using EtherNet/IP

Implicit Messages (process data connections)	<p>1. Exclusive Owner Transport Class: Class 1 Trigger Mode: cyclic O → T [O (Originator/Master) → T (Target/Slave)] fixed/variable size supported Real time transfer format: 32-bit run/idle header Connection Type: Point2Point Priority: Scheduled</p> <p>T → O [T (Target/Slave) → O (Originator/Master)] fixed/variable size supported Real time transfer format: 32-bit run/idle header Connection Type: Multicast, Point2Point Priority: Scheduled</p>
	<p>2. Listen Only Transport Class: Class 1 Trigger Mode: cyclic O → T [O (Originator/Master) → T (Target/Slave)] fixed size supported Real time transfer format: Heartbeat Connection Type: Point2Point Priority: Scheduled</p> <p>T → O [T (Target/Slave) → O (Originator/Master)] fixed/variable size supported Real time transfer format: 32-bit run/idle header Connection Type: Multicast Priority: Scheduled</p>
	<p>3. Input Only Transport Class: Class 1 Trigger Mode: cyclic O → T [O (Originator/Master) → T (Target/Slave)] fixed size supported Real time transfer format: Heartbeat Connection Type: Point2Point Priority: Scheduled</p> <p>T → O [T (Target/Slave) → O (Originator/Master)] fixed/variable size supported Real time transfer format: 32-bit run/idle header Connection Type: Multicast, Point2Point Priority: Scheduled</p>

Explicit Messages	yes
UCMM	is supported
DLR	is supported
Addressing	DIP switch, bus interface parameter, BOOTP and DHCP possible
Access for NORD diagnosis tool	via diagnostics socket on the frequency inverter, or via Ethernet (TCP)
Firmware update	via NORDCON software (TCP)

Features of the bus interface when using PROFINET IO

Communication	RT (Real Time) → Real-time communication for process data
	IRT (Isochronous Real Time) → Isochronous real-time communication for synchronised process data
PROFINET IO addressing	automatic address allocation via IO controller with DCP (Discovery Configuration Protocol)
Data transfer	via Switched Ethernet
Auto negotiation	negotiation of transfer parameters
Auto crossover	transmission and reception cable may be crossed automatically in the switch
Conformance classes	CC-B and CC-C
Access for NORD diagnosis tool	via diagnostics socket on the frequency inverter, or via Ethernet (TCP)
Firmware update	via NORDCON software (TCP)

Installation

Installation location	In defined option slot inside the NORDAC device.
Fastening	with screw fastenings

- 1) With NORDAC *LINK*, this assembly must be selected when ordering. The installation is then carried out at the factory. Subsequent installation is not possible.

Installation steps

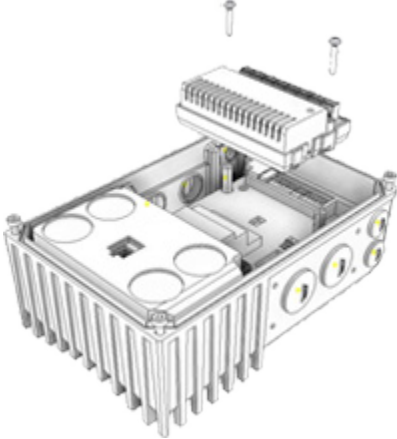
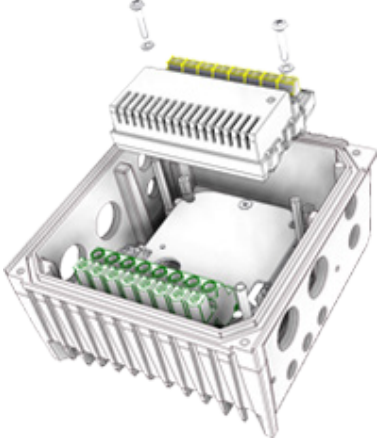
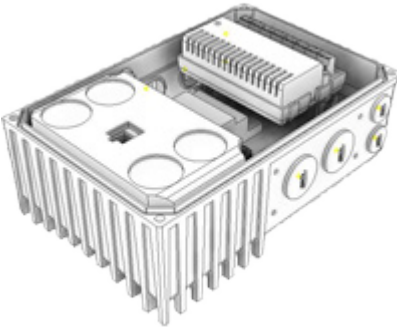
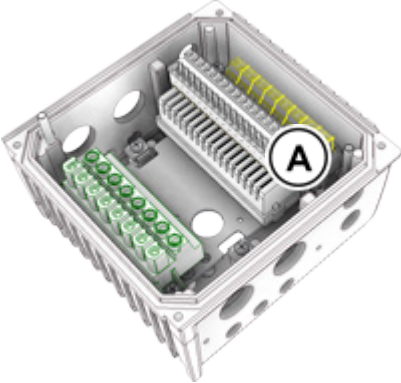
	NORDAC <i>BASE</i>	NORDAC <i>FLEX</i> *)
1.		
2.		

- *) Before carrying out installation step 1 it may be necessary to remove the control terminal bar (A),
The control terminal bar (A) must be fitted after installation step 2.

Connections

Connection is established via terminal strips of the bus interface.

Potential	Contact	Name	Description
1	Ethernet	E8	PHY1 RX- Ethernet connection 2 Receive Data -
		E7	PHY1 RX+ Ethernet connection 2 Receive Data +
		E6	PHY1 TX- Ethernet connection 2 Transmission Data -
		E5	PHY1 TX+ Ethernet connection 2 Transmission Data +
		E4	PHY0 RX- Ethernet connection 1 Receive Data -
		E3	PHY0 RX+ Ethernet connection 1 Receive Data +
		E2	PHY0 TX- Ethernet connection 1 Transmission Data -
		E1	PHY0 TX+ Ethernet connection 1 Transmission Data +
2	System bus level and digital inputs	78	SYS - System bus data cable -
		77	SYS + System bus data cable +
		C1	DIN1 Digital input 1
		C2	DIN2 Digital input 2
		40	GND/0V Reference potential (0 V/GND)
		44	24 V Supply potential (+24 V)
		40	GND/0V Reference potential (0 V/GND)
		44	24 V Supply potential (+24 V)

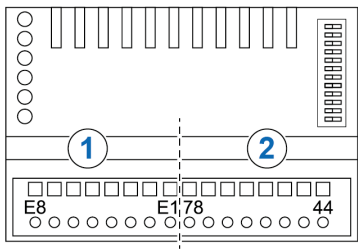

Connection examples

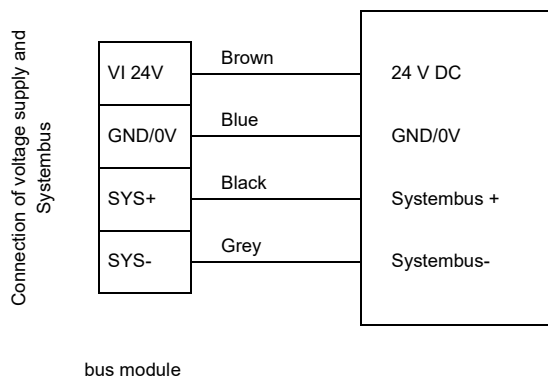

Configuration

Configuration of the bus interface for remote maintenance or for the system bus is via the DIP switches or via parameter **P850**. DIP switch positions are read after a “Power On” of the bus interface.

DIP switch											Meaning		
12	11	10	9	8	7	6	5	4	3	2	1	Address	
X	X	X	0	0	0	0	0	0	0	0	X	0	
X	X	X	0	0	0	0	0	0	0	1	X	1	
X	X	X	0	0	0	0	0	0	1	0	X	2	
X	X	X	-	-	-	-	-	-	-	-	X	-	
X	X	X	1	1	1	1	1	1	1	1	X	255	
											0	Termination resistor system bus not set.	
											1	Termination resistor system bus set.	
			0									TCP tunnel is switched on	
			1									TCP tunnel is switched off	
0	0											Protocol switchable via parameter P899	
0	1											PROFINET	
1	0											EtherCAT	
1	1											EtherNet/IP	

Meaning of symbols	
0	DIP switch in “OFF” position
1	DIP switch in “ON” position
X	DIP switch position not relevant here

1. Terminating resistor system bus (DIP 1)

The system bus must be terminated with a terminating resistor at its two physicals ends. If the bus interface is at the end of the system bus, the DIP 1 switch must be set to “ON”.

2. Address (DIP 2...9)

The “Explicit Device Identification” for EtherCAT can be set via these DIP switches. If the Second Address is set via DIP switch, it cannot be controlled via the NORD parameters.

If EtherNet/IP is used, these DIP switches set the last byte of the IP address. The set IP address can be controlled via parameter **P875**.

If all DIP switches 2...9 are set to “OFF” position, the “Explicit Device Identification” or the IP address can be set via parameter **P850**.

3. TCP rights (DIP 10)

This DIP 10 switch determines the access rights when using the EtherCAT protocol.

“OFF” = Write and read permissions

“ON” = Read-only permissions

If the protocols PROFINET or EtherNet/IP are used, this DIP switch switches the TCP protocol.

“OFF” = TCP On

“ON” = TCP Off

The function of the TCP Ethernet can be defined in parameter **P853**.

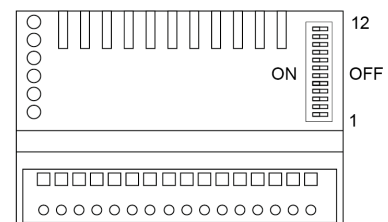

Factory setting DIP switches: **OFF**

4. Ethernet protocol (DIP 11...12)

This DIP switch determines the used Ethernet protocol. In the DIP 11 = 0 and DIP 12 = 0 combination, the protocol can be switched via parameter **P899** ( [BU 2900](#)).

LED indicators

Visualisation of operating statuses of the bus interface is done via LED indicators.

No.	Name	Colour
1	RUN/MS	Dual (red/green)
2	ERR/NS	Dual (red/green)
3	L/A1	Dual (green/orange)
4	L/A2	Dual (green/orange)
5	DEV	Dual (red/green)
6	BUS	Dual (red/green)

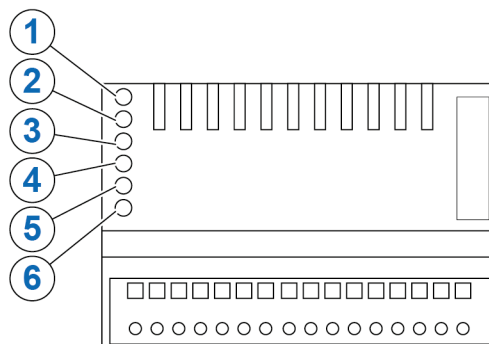

LED L/A1, L/A2

LEDs labelled "L/A" (Link/Activity) indicate the status of the Internet interface.

L/A	Meaning
Off	• No Ethernet connection (check cable connection)
Green on and orange flashing (4 Hz)	• Ethernet connection is established and data is being transmitted
Green on	• Ethernet connection is established. No data is being transmitted.

NORD-specific LED

The LED labelled "DEV" indicates the general device status.

DEV	Meaning
Green on	• Module is ok
Green on and red flashing (1 Hz)	• Frequency inverter in fault state
Green and red on	• Frequency inverter in update mode
Red and green flashing simultaneously	• Update files are transmitted via Ethernet

The LED labelled "BUS" indicates the status of communication at system bus level.

BUS	Meaning
Off	• No supply voltage
Green on	• Process data communication active, or frequency inverter's firmware update
Green flashing (2 Hz)	• No system bus frequency inverter available
Red and green flashing alternately (4 Hz)	• System bus in status "BUS Warning" because <ul style="list-style-type: none"> – no further CAN participant exists. – the CAN controller is in "Error Passive" state. – an EMC interference is present.
Red on	• System bus in state "BUS-OFF"

EtherCAT-specific LED

RUN	State	Meaning
Off	Init	• No communication of process data and parameters
Green flashing (4 Hz)	Pre-Operational	• Parameter communication active • No process data communication
Green single flash	Save Operational	• Parameter communication active • Restricted process data communication • No restrictions to actual values • Setpoints not evaluated
Green On	Operational	• Parameter communication active • Unrestricted parameter communication active

ERR	State	Meaning
Off	No Error	• EtherCAT functioning normally on the bus interface
Red flashing (4 Hz)	Invalid Configuration	• General EtherCAT configuration error, may be generated because of an incorrect XML file
Red single flash	Unsolicited State Change	• Bus interface has changed the EtherCAT state without authorisation
Red double flash	Application Watchdog Timeout	• EtherCAT or FI timeout (P513 or P151)

EtherNET/IP-specific LED

MS	Meaning
Off	• No mains or control voltage
Green On	• Bus interface working correctly
Green flashing (4 Hz)	• Bus interface not configured
Red flashing (4 Hz)	• Minor errors, faulty configuration
Red and Green flashing alternately (4 Hz)	• Power-up, self test

NS	Meaning
Off	• No mains or control voltage
Green On	• CIP connection available
Green flashing (4 Hz)	• IP address configured but no CIP connection available
Red flashing (4 Hz)	• Time-out An "exclusive owner connection" has a timeout error
Red and Green flashing alternately (4 Hz)	• Power-up, self test
Red On	• Double IP IP address used by the bus interface is used already.

PROFINET-specific LED

RUN	Meaning
Off	• No error
Red flashing (1 Hz)	• DCP signal is triggered via the bus.
Red on	• System error / alarm

ERR	Meaning
Off	• No errors
Red flashing (2 Hz)	• No data exchange
Red on	• No configuration or no physical connection

Parameter access and diagnosis

The NORDCON software from version 2.9.1 and higher or optional control units such as the SK PAR-3H ParameterBox provide convenient access to the parameters of the bus interface and allow status information to be read out. In addition, the NORDCON APP – in connection with the NORDAC ACCESS BT Bluetooth stick – offers a practical way of mobile and wireless maintenance as well as commissioning of NORD frequency inverters.

Access is via the RJ12 diagnostics socket of the frequency inverter. The prerequisite for this is that the bus interface is connected to the frequency inverter via the system bus.

When using EtherNet/IP and PROFINET, access is also possible via Ethernet (TCP). This is based on the prerequisite that IP addresses have been set and the necessary rights have been granted.

Further documentation and software (www.nord.com)

Software	Description
Device description files	Device characteristics and parameters

Software	Description
NORDCON	Parameterisation and diagnostic software

Document	Description
BU 0000	Description of NORDCON software
BU 0040	Parameter box manual
BU 0180	Manual for NORDAC <i>BASE</i> frequency inverters
BU 0200	Manual for NORDAC <i>FLEX</i> frequency inverters

Document	Description
TI 275274505	SK TIE4-M12-SYSM System bus output connection extension
TI 275274506	SK TIE4-M12-SYSS System bus input connection extension
TI 275274514	SK TIE4-M12-ETH Ethernet input/output connection extension
BU 0250	Manual for the NORDAC <i>LINK</i> frequency inverter
BU 2900	Manual for Industrial Ethernet bus communication