

SK DCL-950/200-C

Part number: 276 997 200

Link circuit choke

NOTICE

Validity of this document

This document is only valid in combination with the operating instructions of the relevant frequency inverter and under strict compliance with the safety and warning instructions which they contain. All of the information that is relevant for a safe start-up of this module and the frequency inverter is only available under these conditions.

Scope of delivery

1 x	Module	SK DCL-950/200-C
1 x	Enclosed package for creating protection against contact (not IP20)	Shrink tube d = 19 mm, L approx: 300 mm
4 x	Ring cable lug (for connection to FI and choke)	90 mm ² , M8
2 x	Ring cable lug (for connection to PE)	50 mm ² , M8



Usage area

Link circuit choke to improve mains quality. Due to its principle of operation, distortions of the mains voltage caused by the frequency inverter are considerably reduced by the use of a link circuit choke. The harmonic component of the current is reduced to approx. 40% and the power factor (lambda) is increased. The module is installed in the immediate vicinity of the frequency inverter.

Frequency inverter assignment

Permissible frequency inverters (FI)	FI size	FI power
SK 5xxE-752-340-A ... SK 5xxE-902-340-A	9	75 kW / 90 kW

Technical data

General

Temperature range	-10 ... 50°C
Protection class	IP00
Weight	18.5 kg

Temperature class	F (VDE) / Class 155 (UL)
Fastening	4 x M8
Certifications	EN 61558, CE UL (cRU _{US}) E219022

Technical Information / Datasheet	SK DCL-950/200-C			
Link circuit choke	TI 276997200	V 1.5	4115	EN

Dimensions

Housing dimensions	L x W x H [mm]	170 x 153 x 260
Fastening	L x W [mm]	112 x 90

Connections

No.	Designation	Connection*	Type	Torque
1	Intermediate circuit	-DC, CP	M8	12.0 Nm
2	Earth lead	PE	M8	12.0 Nm

* Connection cross-section 75 mm²

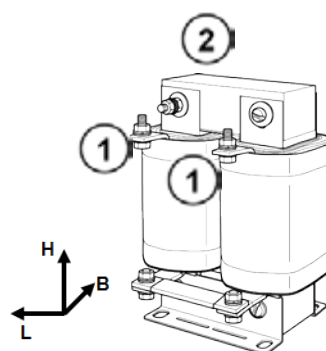

Electrical data

Number of phases		1
Rated voltage	V =	950
Rated current	A =	200
Ripple current (at 300 Hz)	A ~	50 A

Inductance	mH	0.3 ± 10%
Resistance of windings	mΩ	2.14
Power dissipation	W	180

Installation

⚠ DANGER!

Electric shock

Do not work on live components (observe the 5 safety rules!)

Failure to comply with this will result in serious or fatal injuries in case of contact.

5 safety rules:

- Disconnect
- Secure against switching on
- Check for no voltage
- Earth and short circuit
- Cover or guard adjacent live components

⚠ CAUTION

Danger of burns

When in operation, the surface temperature of the device may reach temperatures of approx. 105 °C. To avoid injury or damage to adjacent components, an adequate minimum distance must be maintained or appropriate protective devices must be provided.

Installation location	Inside a control cabinet near to the frequency inverter. Note the load bearing capacity of the mounting plate!
Installation orientation	Floor-standing or on the rear wall of the control cabinet.
Fastening	With screw fastenings

📄 Note

Protection against contact

Adequate protection against accidental contact must be ensured during installation. This protection can, for example, be by use of the enclosed shrink tube.

Installation steps

1.	Install the device near to the frequency inverter on a flat surface (rear wall / floor of the control cabinet) with 4 matching screws, using the fastening holes provided.
2.	Connect the link circuit of the frequency inverter (-DC, CP) to the -DC and CP terminals. Note: The connecting cables must be installed twisted together. 
3.	Earth the choke (connect the PE of the choke to the frequency inverter or the central earthing rail).

Schematic circuit diagram

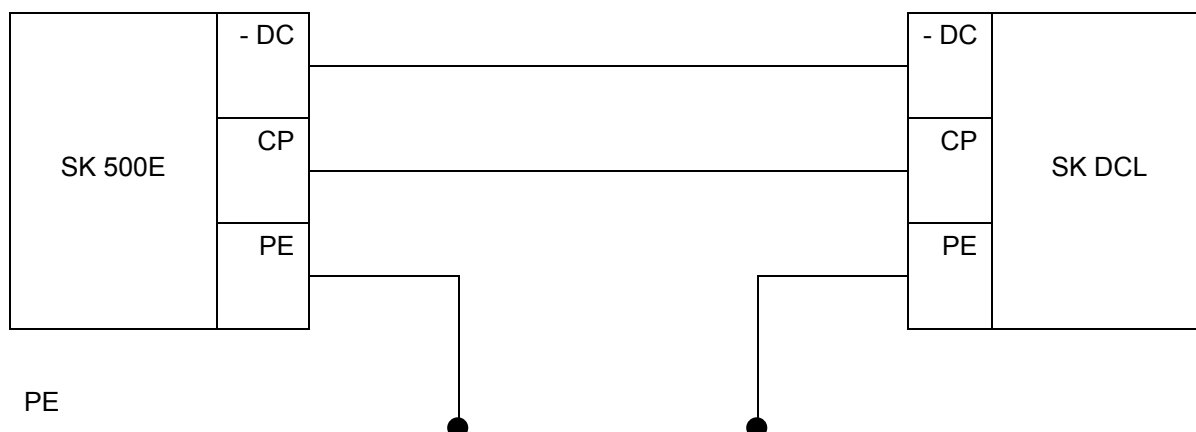

Additional documentation and software (www.nord.com)

Document	Name
BU_0500	SK 500E - SK 535E frequency inverter manual

Document	Meaning
BU_0505	SK 54xE frequency inverter manual