

Supplementary Instructions For ATEX-Designed

NORDAC *trio* SK 300E **Frequency Inverters**

SK 300E-XXX-340-B-3D-T125



ATEX



BU 0310 GB

Getriebebau NORD

GmbH & Co. KG





NORDAC SK 300E frequency inverters for use in areas with explosive gas atmospheres

General remarks

We urgently recommend reading these Operating Instructions before transporting, installing, configuring or servicing a NORDAC frequency inverter. Each person entrusted with any of the tasks mentioned above is supposed to follow both the Basic Operating Instructions and the instructions contained in the present Supplement. All of the safety information mentioned in the said manual and in the present Supplement must strictly be observed to ensure personal and material protection. Prevention of dangerous situations and damages crucially depends on safety instructions to be taken seriously and to be implemented!

Other provisions and requirements to be taken into account include those applicable on a national and local scale as well as the specific parameters and instructions relating to the technical system of which the inverter will be a part.

Important!



In addition you should by all means be aware of the maximum allowable operating speed and the maximum allowable output torque of the reducer unit. These values are indicated on the reducer's type plate and must never be exceeded!

Skilled personnel with the proper qualification



It is presumed that all of the transport, assembly, installation, parameterization and maintenance work is performed by technical personnel qualified for their tasks. The term "qualified" is understood to refer to individuals who, having been properly trained and instructed and on account of their experience and knowledge of relevant standards, accident prevention rules, and the respective operating conditions are qualified to perform the tasks required to set the frequency inverter up for operation. The personnel involved is also supposed to be familiar with First Aid measures and to know how to reach the local rescue services.

If the Operating Instructions have got lost for some reason or other, another copy should be obtained from NORD immediately.

Before starting any of the work related to the frequency inverter make sure that the system is in a dead state electrically!



If the frequency inverter is connected to a motor and a speed reducer, also look for the markings showing to which extent motor and reducer are explosion-proof!

Special designs and construction varieties may differ from the standard types regarding certain technical features. If in doubt, by all means contact the manufacturer stating the type designation and the NORD identification number and ask for the required information.

Safety instructions

As the explosion hazard is definitely increased in areas where the air contains inflammable dust, strict adherence to the general safety instructions and to the instructions for system start-up is indispensable. The drive is supposed to meet the requirements specified in **Guide No. 6052101 for control process design**. If ignited by hot or spark-emitting objects, explosible dust concentrations may cause explosions which may result in grave or even fatal personal injuries and in substantial material damage.

It is absolutely necessary that each person responsible for the use and operation of motors and frequency inverters in hazardous locations is well schooled in how to do this safely in the appropriate fashion.

Always disconnect the supply voltage before you open the frequency inverter to connect the electrical lines or to perform any other work on the device, and protect it against circuit reclosure! **Warning!** Temperatures inside the frequency inverter and the motor may occasionally exceed the maximum allowable surface temperature of the housing. That is why the frequency inverter must never be opened or detached from the motor while it is surrounded by an atmosphere which contains explosible dust!

Check the inverter for dust deposits regularly. When there is more dust than allowed, heat from the inverter can no longer be carried off as effectively as required! If there is doubt about whether the inverter is still performing reliably, the motor needs to be stopped !

Always to ensure dust protection of the motor as well is immensely important with regard to explosion protection.

Repairs on the frequency inverter must not be performed by any other party but NORD as the manufacturer.



Instructions for parameterization / Scope of application

As the marking shows, the frequency inverter and the motor are suitable for use in zone 22 (non-conductive dust).

The marking is as follows:   II 3D T125°C

For zone 2 operation of frequency and motor, cable entries must ensure at least the IP 55 type of protection. Openings which are not in use have to be sealed with dummy plugs (minimum type of protection IP 55).

The frequency inverter ensures protection of the motor against overheating by evaluating the PTC resistor of the motor. For this effect to be obtained, digital input 1 must be assigned the "PTC resistor" function (P420 = 13). Be sure, too, to select the NORD motor you are using from the motor list (P200). When a motor from a different manufacturer is used the motor parameter data (requested to be set in P201 to P208) must be copied from the type plate of the motor. Best verify whether the settings of the respective parameters correspond with the type plate before starting the motor.

Furthermore the frequency inverter should be parameterized so as to prevent the motor from running at a speed greater than $3000 \frac{1}{\text{min}}$. For a four-pole motor the 'maximum frequency' should be set to a value less than or equal to 100 Hz (P105 \leq 100). **When you make this setting don't forget to take the maximum allowable output speed of the gearbox into account!!!** Also activate the "I²t motor" control in parameter P535.

Table of the required parameter settings:

Parameter	Setting value	Default	Description
P105 Maximum frequency	≤ 100 Hz	[50]	This value is related to a 4-pole motor. Always select a value that will ensure that a motor speed of 3000 rpm is not exceeded.
P200 Motor list	No. from BU 0300 according to the motor rating	[0]	When a NORD motor is connected, selecting the appropriate number will activate the default settings of the motor used.
P201 – P208 Motor data	Data obtained from the type plate	[***]	When the motor is from a different manufacturer, the motor data from the type plate must be copied to the applicable parameters.
P420 Function dig. input1	[13] PTC resistor input	[13]	Digital input 1 must be parameterized to ensure the PTC resistor function and with it temperature control of the motor.
P535 I ² t motor	[1] activated	[0]	The I ² t setting [1] for over current control of the motor is imperative.

Set point potentiometer

The category-3D SK 300E inverter can be equipped with a potentiometer meeting ATEX standards which can be used to vary the set point (e.g. the speed) on the device.

Designation: Potentiometer ATEX22 - SK 300E

Part number: 075142000

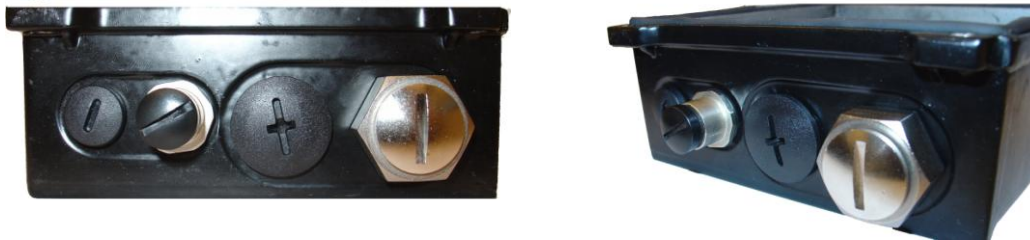

The selected set point can be adjusted with a screwdriver. As far as the potentiometer is concerned, it will meet ATEX requirements due to a sealing cap which can be screwed on. For continuous operation the sealing cap must remain fixed.

Set point adjustment with a screwdriver



Technical data:

Resistance value of the potentiometer: 10 kilo-ohms

Wire colours on the potentiometer	Designation	Terminal
red	+10V	11
black	AGND / 0V	12
green	analogue input+ analogue input 1	14

For a potentiometer to be used with the SK 300E frequency inverter, the device must always be equipped with a customer interface (Basic I/O or Standard I/O)!

Typical assignments of the Basic I/O module terminals:

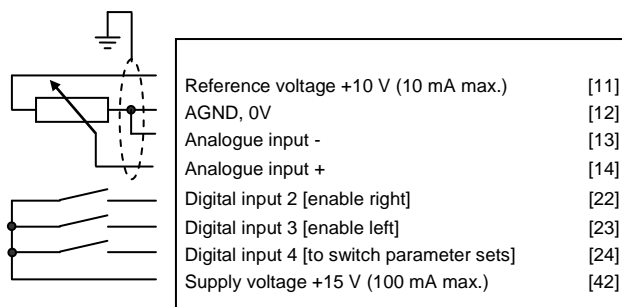



Getriebebau NORD GmbH & Co. KG
Rudolf-Diesel-Str. 1, D-22941 Bargteheide, Germany
Phone: +49 (0) 4532-401-0 Fax: +49 (0) 4532-401-555 <http://www.nord.com>



Declaration of EC-Conformity

in the sense of the directive 94/9/EC annex VI

Getriebebau Nord GmbH & Co. KG herewith declares,
that the inverters of the product range

- SK 300E-xxx-340-B-3D-T125 -

product classification: group II, category 3D (zone 22), temperature class: 125 °C

are conform with the following regulation:

Directive on **94/9/EC**
equipment and protective systems
for use in explosive atmospheres

Applied Standards:

EN 50281-1-1:1998	Electrical apparatus for use in the presence of combustible dust
EN 50281-1-2:1998	Electrical apparatus for use in the presence of combustible dust
EN 50014:1997	Electrical apparatus for potentially explosive atmospheres General requirements
EN 60034-5:2001	Specification for degrees of protection provided by enclosure (IP-Code)
EN 60529:1991	Specification for degrees of protection provided by enclosure (IP-Code)

Other important and necessary documentation:

Project outline No. 6052101
Enterprise of explosion-proof motors of the category 3D
in accordance with RL 94/9/EC at frequency inverters

Supplement to the BU 0310 GB, no. 6073101/4704
Operating Instructions Instructions for the starting-up and maintenance

Bargteheide, 01.03.2004

U. Küchenmeister
General Manager

By proxy, F. Wiedemann
Technical Manager inverters



Contact

If the **frequency inverter** needs to be repaired, please send it to your local NORD distribution agency.

If you would like **more or specific information** regarding the **frequency inverter** or if you want to send us the complete aggregate for the **geared motor** (or the complete *trio* SK 300E) to **be repaired**, kindly contact:

Getriebebau NORD GmbH & Co. KG
Rudolf-Diesel-Straße 1
D-22934 Bargteheide / Hamburg

Phone: 04532 / 401-0
Fax: 04532 / 401-555

Before you dispatch a frequency inverter for repair, please remove any parts which are not genuine, because we are **not** in a position to **guarantee** any parts which may still be attached such as line cables, potentiometers, external display units etc.

Additional documentation on all of NORD's electronic products is provided on our site in the internet, in German, English, French, and in a number of other languages as well.

>>> <http://www.nord.com> <<<

NORD Offices in Germany



Getriebebau NORD GmbH & Co. KG

Rudolf- Diesel- Str. 1 · 22941 Bargteheide

Telephon 04532 / 401 - 0

Telefax 04532 / 401 - 253

info@nord-de.com

www.nord.com



North Branch

Getriebebau NORD GmbH & Co. KG

Rudolf- Diesel- Str. 1 · 22941 Bargteheide

Telephone 04532 / 401 - 0

Telefax 04532 / 401 - 253

NL-Bargteheide@nord-de.com

Sales office Bremen

Getriebebau NORD GmbH & Co. KG

Stührener Weg 27 · 27211 Bassum

Telephone 04249 / 9616 - 75

Telefax 04249 / 9616 - 76

NL-Bremen@nord-de.com

Representation:

Hans-Hermann Wohlers Handelsgesellschaft mbH

Ellerbuscher Str. 179 · 32584 Löhne

Telephone 05732 / 40 72

Telefax 05732 / 123 18

NL-Bielefeld@nord-de.com

South Branch

Getriebebau NORD GmbH & Co. KG

Katharinenstr. 2-6 · 70794 Filderstadt-
Sielmingen

Telephone 07158 / 95608 - 0

Telefax 07158 / 95608 - 20

NL-Stuttgart@nord-de.com

Sales office Nürnberg

Getriebebau NORD GmbH & Co. KG

Schillerstr. 3 · 90547 Stein

Telephone 0911 / 67 23 11

Telefax 0911 / 67 24 71

NL-Nuernberg@nord-de.com

Sales office München

Getriebebau NORD GmbH & Co. KG

Untere Bahnhofstr. 29a · 82110 Germering

Telephone 089 / 840 794 - 0

Telefax 089 / 840 794 - 20

NL-Muenchen@nord-de.com

West Branch

Getriebebau NORD GmbH & Co. KG

Großenbaumer Weg 10 · 40472 Düsseldorf

Telephone 0211 / 99 555 - 0

Telefax 0211 / 99 555 - 45

NL-Duesseldorf@nord-de.com

Sales office Butzbach

Getriebebau NORD GmbH & Co. KG

Marie- Curie- Str. 2 · 35510 Butzbach

Telephone 06033 / 9623 - 0

Telefax 06033 / 9623 - 30

NL-Frankfurt@nord-de.com

East Branch

Getriebebau NORD GmbH & Co. KG

Leipzigerstr. 58 · 09113 Chemnitz

Telephone 0371 / 33 407 - 0

Telefax 0371 / 33 407 - 20

NL-Chemnitz@nord-de.com

Sales office Berlin

Getriebebau NORD GmbH & Co. KG

Heinrich- Mann- Str. 8 · 15566 Schöneiche

Telephone 030 / 639 79 413

Telefax 030 / 639 79 414

NL-Berlin@nord-de.com